

LIBRARY
ROYAL AIRCRAFT ESTABLISHMENT
BEDFORD.

R. & M. No. 3260



MINISTRY OF AVIATION

AERONAUTICAL RESEARCH COUNCIL
REPORTS AND MEMORANDA

A Proposed Apparatus for Measuring Oscillatory Aerodynamic Derivatives

By L. H. G. STERNE

LONDON: HER MAJESTY'S STATIONERY OFFICE

1962

PRICE 3s. 6d. NET

A Proposed Apparatus for Measuring Oscillatory Aerodynamic Derivatives

By L. H. G. STERNE

COMMUNICATED BY THE DEPUTY CONTROLLER AIRCRAFT (RESEARCH AND DEVELOPMENT),
MINISTRY OF AVIATION

*Reports and Memoranda No. 3260**

October, 1959

Summary. This Report describes the principles to be used in designing an apparatus, including a half-model of an aircraft, for measuring longitudinal oscillatory aerodynamic derivatives in the R.A.E. High Speed Tunnel. The model is to be oscillated inexorably in pitch about two axes, one near the leading edge and one near the trailing edge.

The scheme has the following novel features:

- (i) The 'fixed parts' of the oscillating mechanism are to be carried on a floating 'raft', the alternating aerodynamic force on the model being deduced from the force required to hold the 'raft' in position.
- (ii) The in-phase and quadrature components of the force on the 'raft' will be found by measuring the d.c. output of a strain-gauge bridge powered by an a.c. supply synchronous with the inexorable oscillation.

1. *Introduction.* An apparatus is being designed for measuring longitudinal oscillatory aerodynamic derivatives with half-models in the R.A.E. High Speed Wind Tunnel. The immediate need is to provide data for longitudinal stability calculations at high Mach numbers over a range of frequency corresponding to the 'short-period' pitching oscillations of aircraft.

The plan is to oscillate models in pitch about two axes, one near the leading edge and one near the trailing edge of the root section. The tests are to cover a range of Mach number up to about 0.95 and a range of frequency parameter from 0.05 to 0.20. The components of lift and of pitching moment, in phase and in quadrature with the motion, will be measured for each axis of oscillation. These measurements are sufficient to determine the eight derivatives of lift and moment with respect to the velocities w and q .

2. *Method of Oscillation.* The possible methods by which models can be oscillated to measure stability derivatives fall into three classes:

- (i) The model is supported elastically and an impulse applied to start an oscillation at the natural frequency of the system. This frequency is not the same as the natural frequency *in vacuo*; the difference is a measure of the moment of aerodynamic force (about the axis of oscillation) in phase with the angular displacement. The rate of decay or growth is a measure of the quadrature component of this moment.

* First issued as an unpublished R.A.E. Technical Memorandum in March, 1951. Subsequently issued as R.A.E. Tech. Note No. Aero. 2656—A.R.C. 14,227.

(ii) This is similar in principle to method (i) except that the oscillation is maintained at a constant amplitude by exerting on the model a measured couple in quadrature with the displacement.

(iii) The model is oscillated inexorably at a prescribed amplitude and frequency.

The inexorable method has been chosen for the High Speed Tunnel tests. This choice was made partly because of the requirement of the tests and partly because of the general layout of the tunnel.

Very satisfactory and elegant methods of types (i) and (ii) have been developed to measure the in-phase and quadrature moments of aerodynamic force about the axis of oscillation. These, however, are insufficient to determine all the relevant derivatives; it is also necessary to measure the force exerted at the axis. To do this requires the development of a technique of measurement which robs both methods of oscillation of much of the advantage in elegance and simplicity which they have over the inexorable method.

To vary the frequency of oscillation in either method (i) or method (ii), the stiffness of the elastic support has to be changed; the relative inaccessibility of the working section of the High Speed Tunnel would make this a particularly lengthy and tedious business. In employing the inexorable method, a remotely controlled electric motor will be used to oscillate the model, the frequency being varied by changing the rotational speed of the motor.

3. *Method of Carrying the Mechanism.* In oscillating a model inexorably, the usual practice is to mount the driving motor, together with the other 'fixed parts' of the mechanism, rigidly to earth. In the High Speed Tunnel tests however it is intended to adopt quite different tactics.

The plan is to mount the 'fixed parts' of the mechanism on a rigid but floating framework or 'raft' located in or close to the plane of the roof of the working section. The half-model will be carried on the underside of this raft and the raft itself will be suspended by cables attached to points in the tunnel structure above the working section.

Two ties located in the plane of the raft, one ahead of the model and one behind it, will anchor the raft to the tunnel structure. Strain gauges will be attached to these ties to measure the forces exerted by them in restraining the raft from moving under the action of aerodynamic force on the model. A figure illustrates the proposed layout; the motor and driving mechanism are not shown.

The inertial force due to the oscillation of the model will be large and it is proposed to cancel its effect by oscillating two sets of balance masses, synchronously with the model, using the same driving motor. One set of masses will be oscillated in phase with the model and will be located above the raft; the other set will be oscillated at 180 deg out-of-phase and located in or close to the plane of the raft. The fixed parts of these balance weight systems will be attached to the raft. In this way it is hoped to achieve a balance of inertial force in the lift direction together with moments of inertial force about the pitching and rolling axes.

The purpose of this balancing is three-fold. With a perfect balance of the inertial forces, and their moment about the pitching axis, the strain in the ties and the aerodynamic force on the model will be zero together; this will somewhat simplify the calculation of the aerodynamic force from the measured strains in the ties. Secondly, at least partial balance is required if the strains due to aerodynamic force are not to be swamped by inertial effects. Finally, partial balance about the rolling axis is also necessary; otherwise the cables would not remain in tension throughout the oscillation of the model. This would impose a large vertical shear action in the ties and would make it difficult to design them to measure lift and pitching moment accurately.

The length of the cables and the stiffness of the ties will be such that there will be no significant horizontal component of force in the cables. Thus, as far as practicable, the strains measured in the ties will result directly from the aerodynamic forces which we want to determine. Some of the ways in which these strains are modified by other actions are detailed below (Section 6).

4. *Method of Measurement.* The positioning of the strain-gauge balances is such that the effect of lift and pitching moment will be to apply a shearing action in them and, by measuring this shearing action in each tie, both lift and pitching moment can be deduced. The design of the ties will be similar in principle to that of the shear-type drag balance used in the measurement of steady force on sting models.

Wire resistance strain gauges will be cemented to each tie and connected together in the form of a Wheatstone bridge.

The instantaneous output from such a bridge is proportional to the product of the strain and the input voltage. If the input voltage is provided by a synchronous generator, coupled to the inexorable mechanism and giving an e.m.f. equal to $E \sin \Omega t$, and the strain at the same instant is $(S_I \sin \Omega t + S_0 \cos \Omega t)$, the output from the bridge is proportional to $(S_I \sin \Omega t + S_0 \cos \Omega t) E \sin \Omega t$. The d.c. part of this signal is equal to $\frac{1}{2} E S_I$ where S_I is the component of the strain in phase with the generator output.

This principle will be used to measure the components of strain of both bridges in phase and in quadrature with the displacement of the model. The power to the gauges will be supplied alternately by two 'mag-slips' set at 90 deg to one another, one being in phase with the displacement of the model.

5. *Model Design.* The problem of designing an optimum model for this work involves a compromise between conflicting requirements. The frequencies of oscillation at the larger Mach numbers of the tests are high and a fundamental problem in the design of a suitable model is to obtain a satisfactorily high natural frequency. The design of the oscillating mechanisms is eased if the model is light and the distortion of the model is minimised by designing it to have a large absolute stiffness. These three features are clearly incompatible and it has been decided, at least initially, to concentrate on the design of a model with a high natural frequency and of relatively light construction; the Reynolds number is necessarily low at high Mach numbers in High Speed Tunnel tests and the need for a large absolute stiffness may be comparatively less important.

To obtain a high natural frequency, the first obvious requirement is to choose a material of construction with a high ratio of Young's modulus to density. This ratio is roughly the same for a wide range of materials in common use in engineering. The following table gives approximate values for a number of likely materials.

Material	Density (lb/ft ³)	$\sqrt{(E/P)} \times 10^{-3}$ (ft/sec)
Brass	530	11
Steel	490	17
Light alloy	170	17
Compressed birch	60	14
Teak	45	14
Canadian spruce	27	16
Balsa	6 to 12	14

The highest frequency can be obtained from a composite construction, in which each span-wise section consists of a skin of high density material covering a low density core, and in which the mean density of the root section is greater than the tip sections.

From dimensional considerations it follows that the natural frequency is inversely proportional to model scale. Hence for a given frequency parameter ($\omega = 2\pi fc/V$), the ratio of the frequency of oscillation (f) to the natural frequency (n) is independent of scale.

Considerations of model strength are also most easily met by a composite construction embodying essentially the same features as those dictated by considerations of stiffness. For a wing of homogeneous construction (of density m), the component of stress at any point due to inertial force is proportional to $m\omega^2 V^2$; and the component due to aerodynamic force is proportional to ρV^2 . Hence for constant m , ρ , ω and V (but not for constant Reynolds number) all stresses are also independent of model scale.

In order to obtain the highest possible Reynolds number, the largest model will be designed that will allow the tunnel to run without choking up to a Mach number of about 0.95.

As the strength of most engineering materials is roughly proportional to density, there is no merit in a heavy wing from the point of view of inertial forces; but there is for aerodynamic forces.

One half-model typical of a high-speed aircraft has been made. The inner core is of balsa; this is covered by a skin of spruce at the tip sections and by compressed birch at the root. The leading dimensions of the model are:

Mean chord	1.5 ft
Span (of half-model)	2.5 ft
Thickness/Chord	12.5 per cent to 7.5 per cent
Sweep-back	45 deg at max t/c
Taper ratio	2:1
Fundamental natural frequency (as measured)	49 per sec

Corresponding to a mean chord of 1.5 ft the range of absolute frequency in terms of frequency parameter and Mach number is given by the following table.

ω	M	f (per sec)
0.05	0.5	3
0.20	0.95	24

The frequency of oscillation is thus always less than half the natural frequency of the model.

6. *Relationship Between the Force in the Ties and the Aerodynamic Force.* If the tunnel shell were stationary and the complete mechanism, including the ties and the model were made absolutely rigid, and the inertial forces and their moments were precisely in balance, an appeal to d'Alemberts' principle leads to the conclusions that the force in the ties at any instant is precisely equal to the aerodynamic force on the model. Any frictional forces in the mechanism would increase the power required of the driving motor but would not appear as an action at the ties. The effects of certain departures from the ideal postulated above are now considered.

Any vibratory displacement of the tunnel shell, or rather of the parts to which the ties are attached, will cause a corresponding displacement of the whole mechanism, moving and fixed parts equally. The inertial force arising from this movement will be balanced by a force in the ties but if its frequency is different from that of the inexorable oscillation there will be no effect on the d.c.

component of the current generated by the strain-gauge bridges. However, the current generated will have an a.c. component of a frequency equal to the difference of the two frequencies and, if these are close together, the difficulties of recording could be considerable.

Flexibility of the tunnel structure would cause an inertial force of the same frequency as that of the inexorable oscillation. Its magnitude at any frequency would be proportional to the force exerted by the ties on the structure. For a given force, however, there could be a change with frequency both in magnitude and phase. It is very important, as far as possible, to eliminate any damping in the attachment of the ties to the tunnel structure so as to make the phase shift negligible. If this is done, the effect of flexibility in the tunnel structure is equivalent to a change, with frequency, in the calibration of the strain-gauge bridge.

Flexibility in the ties themselves will allow a movement of the whole mechanism in an exactly similar way to that of the tunnel structure. The ties must be flexible in order to measure the forces carried in them but, in fact, they will have to be made very stiff by most standards. It is hoped that the natural frequency of the raft on the ties will be several times the highest frequency of oscillation.

The flexibility of the tunnel structure and of the ties will have the additional effect of increasing the aerodynamic forces by increasing the amplitude of oscillation but this should be negligible.

Flexibility in the model could produce significant effects both in the inertial and aerodynamic forces in the model. As the free oscillations of the model are certain to be heavily damped, these effects amount to a change in phase as well as in magnitude.

If the inertial forces of the moving parts are not precisely in balance the effect is equivalent to a change in the in-phase aerodynamic force on the model. This fact will be used to calibrate the recording system in still air by producing a known out-of-balance force over the whole frequency range.

Although every effort will be made to correct the measured forces for effects due to flexibility of the model it is perhaps worth noting that the oscillating forces on a full-scale aircraft are affected by wing flexibility to a comparable extent. At high frequency parameter and high Mach number the stability and aero-elastic domains over-lap, the elastic effects being independent of model scale.

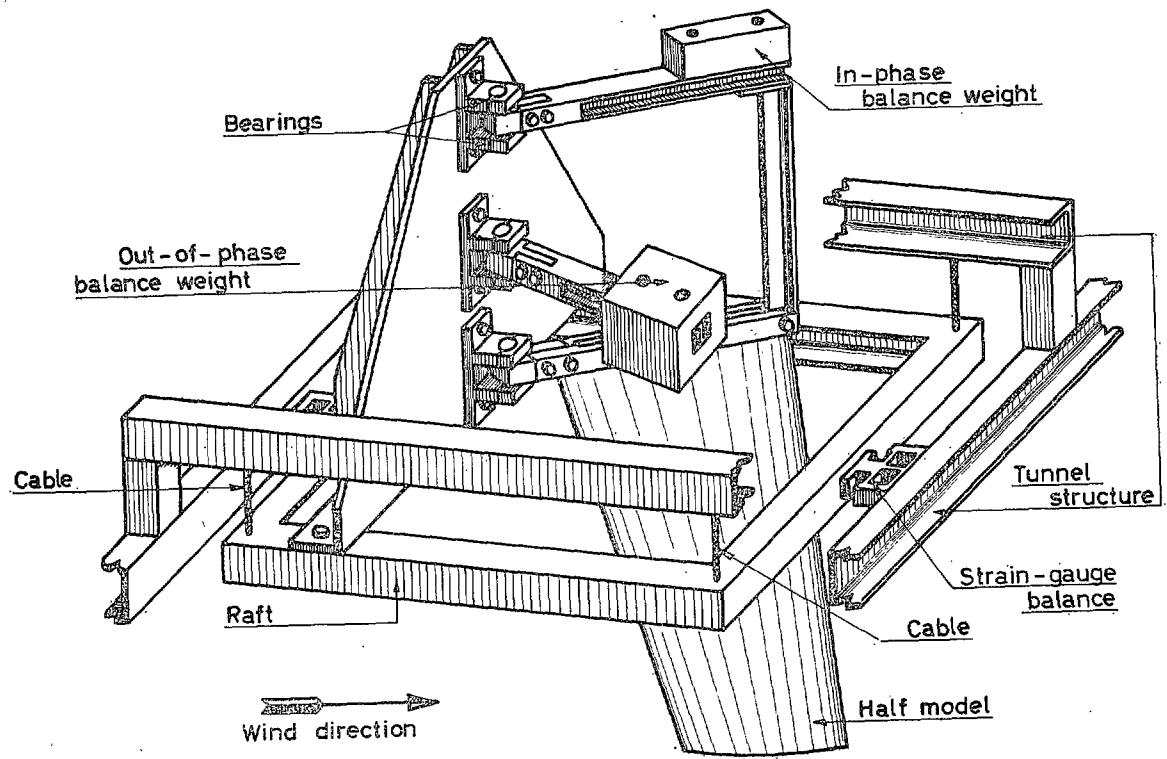

FIG. 1. Proposed oscillatory-derivative apparatus.
 (Driving motor not shown)

Publications of the Aeronautical Research Council

ANNUAL TECHNICAL REPORTS OF THE AERONAUTICAL RESEARCH COUNCIL (BOUND VOLUMES)

- 1941 Aero and Hydrodynamics, Aerofoils, Airscrews, Engines, Flutter, Stability and Control, Structures. 63s. (post 2s. 3d.)
- 1942 Vol. I. Aero and Hydrodynamics, Aerofoils, Airscrews, Engines. 75s. (post 2s. 3d.)
Vol. II. Noise, Parachutes, Stability and Control, Structures, Vibration, Wind Tunnels. 47s. 6d. (post 1s. 9d.)
- 1943 Vol. I. Aerodynamics, Aerofoils, Airscrews. 80s. (post 2s.)
Vol. II. Engines, Flutter, Materials, Parachutes, Performance, Stability and Control, Structures. 90s. (post 2s. 3d.)
- 1944 Vol. I. Aero and Hydrodynamics, Aerofoils, Aircraft, Airscrews, Controls. 84s. (post 2s. 6d.)
Vol. II. Flutter and Vibration, Materials, Miscellaneous, Navigation, Parachutes, Performance, Plates and Panels, Stability, Structures, Test Equipment, Wind Tunnels. 84s. (post 2s. 6d.)
- 1945 Vol. I. Aero and Hydrodynamics, Aerofoils. 130s. (post 3s.)
Vol. II. Aircraft, Airscrews, Controls. 130s. (post 3s.)
Vol. III. Flutter and Vibration, Instruments, Miscellaneous, Parachutes, Plates and Panels, Propulsion. 130s. (post 2s. 9d.)
Vol. IV. Stability, Structures, Wind Tunnels, Wind Tunnel Technique. 130s. (post 2s. 9d.)
- 1946 Vol. I. Accidents, Aerodynamics, Aerofoils and Hydrofoils. 168s. (post 3s. 3d.)
Vol. II. Airscrews, Cabin Cooling, Chemical Hazards, Controls, Flames, Flutter, Helicopters, Instruments and Instrumentation, Interference, Jets, Miscellaneous, Parachutes. 168s. (post 2s. 9d.)
Vol. III. Performance, Propulsion, Seaplanes, Stability, Structures, Wind Tunnels. 168s. (post 3s.)
- 1947 Vol. I. Aerodynamics, Aerofoils, Aircraft. 168s. (post 3s. 3d.)
Vol. II. Airscrews and Rotors, Controls, Flutter, Materials, Miscellaneous, Parachutes, Propulsion, Seaplanes, Stability, Structures, Take-off and Landing. 168s. (post 3s. 3d.)

Special Volumes

- Vol. I. Aero and Hydrodynamics, Aerofoils, Controls, Flutter, Kites, Parachutes, Performance, Propulsion, Stability. 126s. (post 2s. 6d.)
- Vol. II. Aero and Hydrodynamics, Aerofoils, Airscrews, Controls, Flutter, Materials, Miscellaneous, Parachutes, Propulsion, Stability, Structures. 147s. (post 2s. 6d.)
- Vol. III. Aero and Hydrodynamics, Aerofoils, Airscrews, Controls, Flutter, Kites, Miscellaneous, Parachutes, Propulsion, Seaplanes, Stability, Structures, Test Equipment. 189s. (post 3s. 3d.)

Reviews of the Aeronautical Research Council

1939-48 3s. (post 5d.)

1949-54 5s. (post 5d.)

Index to all Reports and Memoranda published in the Annual Technical Reports

1909-1947

R. & M. 2600 6s. (post 2d.)

Indexes to the Reports and Memoranda of the Aeronautical Research Council

Between Nos. 2351-2449

R. & M. No. 2450 2s. (post 2d.)

Between Nos. 2451-2549

R. & M. No. 2550 2s. 6d. (post 2d.)

Between Nos. 2551-2649

R. & M. No. 2650 2s. 6d. (post 2d.)

Between Nos. 2651-2749

R. & M. No. 2750 2s. 6d. (post 2d.)

Between Nos. 2751-2849

R. & M. No. 2850 2s. 6d. (post 2d.)

Between Nos. 2851-2949

R. & M. No. 2950 3s. (post 2d.)

Between Nos. 2951-3049

R. & M. No. 3050 3s. 6d. (post 2d.)

HER MAJESTY'S STATIONERY OFFICE

from the addresses overleaf

© *Crown copyright* 1962

Printed and published by
HER MAJESTY'S STATIONERY OFFICE

To be purchased from
York House, Kingsway, London W.C.2
423 Oxford Street, London W.1
13A Castle Street, Edinburgh 2
109 St. Mary Street, Cardiff
39 King Street, Manchester 2
50 Fairfax Street, Bristol 1
35 Smallbrook, Ringway, Birmingham 5
80 Chichester Street, Belfast 1
or through any bookseller

Printed in England