

N.A. 71

R. & M. No. 2837

(13,903)

A.R.C. Technical Report

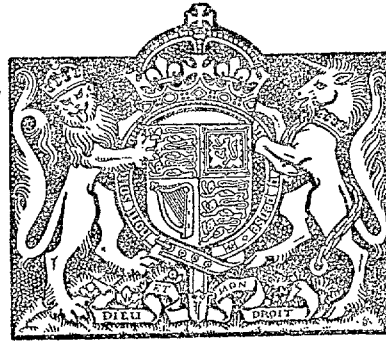

NATIONAL AERONAUTICAL
ESTABLISHMENT
15 OCT 1954
NR. CLAPHAM, BEUS.

NATIONAL AERONAUTICAL
ESTABLISHMENT
4 OCT 1954
LIBRARY

MINISTRY OF SUPPLY

AERONAUTICAL RESEARCH COUNCIL
REPORTS AND MEMORANDA

The Stress Distribution in a Swept-back Box-beam with Perpendicular Ribs

By

P. B. HOVELL, B.Sc.

Crown Copyright Reserved

LONDON: HER MAJESTY'S STATIONERY OFFICE

1954

FIVE SHILLINGS NET

The Stress Distribution in a Swept-back Box-beam with Perpendicular Ribs

By

P. B. HOVELL, B.Sc.

COMMUNICATED BY THE PRINCIPAL DIRECTOR OF SCIENTIFIC RESEARCH (AIR),
MINISTRY OF SUPPLY

*Reports and Memoranda No. 2837**
December, 1950

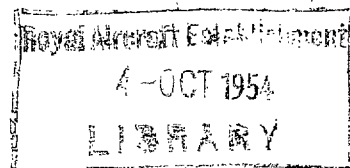

Summary.—A solution is obtained for the distribution of internal load in a swept-back box-beam of rectangular cross-section under any system of external loading. The theory, based upon strain energy, is considered exact when the ribs are perpendicular to the spars and when the spanwise bending loads are taken by the spar booms.

The general solution for encastré root conditions is given. Extensions of the method to cover root flexibility and cut-outs in the top or bottom skins are discussed.

A numerical example of a simple two-spar box is investigated for a range of sweepback angle of 0 deg. to 40 deg. for an encastré root condition. The analysis shows that appreciable redistributions of load in the box, compared with the unswept box, are obtained when either torque or bending moment is applied to the beam.

LIST OF SYMBOLS

P	Vertical load
h	Spar depth
b	Distance between the spars
λ_n	The transfer coefficient at n th rib
θ	Angle of sweep
p	rib pitch
A	Boom area (front spar)
A'	Boom area (rear spar)
k_1, k_2, k_3, k_4	Ratio of boom areas in bays 1, 2, 3, 4 (front spar)
k'_1, k'_2, k'_3, k'_4	Ratio of boom areas in bays 1, 2, 3, 4 (rear spar)
z	$b \tan \theta / p$
E	Young's modulus—boom material
G	Modulus of rigidity—skins and webs
t_s, t'_s	Top and bottom skin thicknesses

* R.A.E. Report Structures 98, received 5th April, 1951.

LIST OF SYMBOLS—*continued*

t_w, t_w'	Web thicknesses
t_R	Rib thickness, equal except for rib 1
t_R/α	Rib thickness of rib 1
C	} Defined in Tables 1 and 2
C'	
D	
D'	
F	
H	

1. *Introduction.*—The problem of the stress distribution in swept-back wings has been investigated in a number of reports. Wittrick¹ (1948) dealt with regions of the wing surface remote from the root, on the assumption of rigid ribs lying in the direction of flight. The more practical case of flexible ribs was investigated by Mansfield² (1949) and Hemp³ (1950). They determined the influence of rib-flange stiffness on the stringer sheet when the ribs are at angles other than 90 deg to the stringers. Their solutions involved the determination of stress functions which satisfied certain boundary conditions, and are applicable only at distances from the root of the wing. An approximate theory for the effects of root restraint was also given by Hemp³ assuming that rib webs are rigid in shear and that the mode of deformation in the restrained condition is similar to the mode with no restraint.

The present report treats the problem from a different aspect and uses a minimum-energy criterion to determine the stress distribution in a two-spar box-beam for any system of loading and takes the root restraint into account. The solution is exact for a parallel rectangular box-beam in which flexible ribs are perpendicular to spars that carry the whole of the bending loads in concentrated booms.

2. *Statement of the Problem and Method of Solution.*—Fig. 1 shows a rectangular two-spar box-beam with an applied load at the intersection of the r th rib and the rear spar

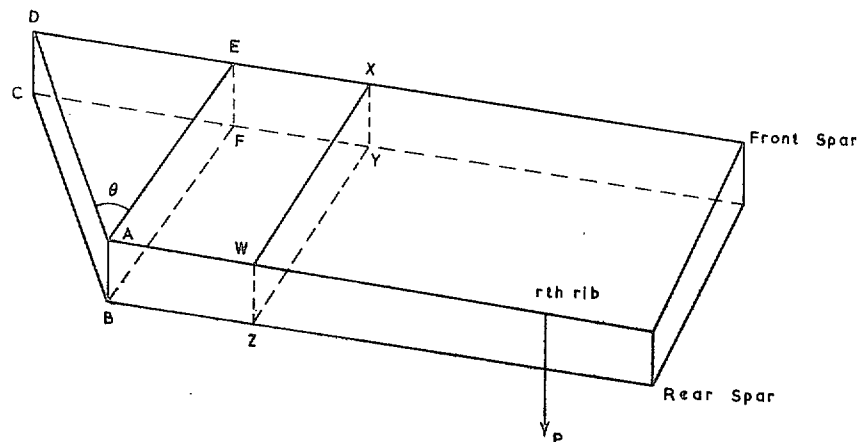

FIG. 1. Two-spar box-beam under vertical load P .

The determination of the stresses is obtained by the consideration of sections, *e.g.*, WXYZ, parallel to the rib ABEF, inclined at θ deg to the root rib ABCD where θ is the angle of sweep. The load carried by the front spar booms will be influenced by the flexibility of the spar CDXY compared with that of the rear spar ABWZ; and consequently in the distribution of the direct load in the spar booms, the additional flexibility of the front spar compared with that in the unswept box must be taken into account.

A comparatively simple solution can be found when the box is a two-spar beam. The rear spar (Fig. 1), under the action of the load P , will tend to deflect and will be restrained by the torsional stiffness of the box-beam and the bending stiffness of the front spar. Thus a certain proportion of the load P will be transferred to the front spar, and furthermore this transfer will only be effected at the ribs. Each rib can be assumed to transfer a proportion λ of the applied load, and the problem then reduces to the determination of the load distribution in terms of P and λ_r ($r = 1$ to N ; N being the number of ribs). A solution is obtained by calculating the strain energy of this system and minimising the energy with respect to each λ to produce N simultaneous linear equations of N unknowns.

3. *The Application of the Method to a Two-spar Rectangular Box-beam (with no taper) with Ribs Perpendicular to the Spars.*—3.1. *Basic assumptions.*—(a) The beam is of rectangular section and two-spar construction, and there is no taper.

(b) The skins and webs carry shear load only and do not contribute to the bending strength of the beam.

(c) The root of the beam is encastré.

(d) The ribs are perpendicular to the spars, and are free to warp out of their planes. They have a shear attachment to the skins and webs, but cannot transmit a bending moment in their own plane to the spars.

(e) The transfer of load from one spar to the other can take place only at the ribs.

(f) The distribution of loads will be such that the strain energy of the system is a minimum.

(g) Buckling of the skin and web plates does not occur.

3.2. *Discussion of the assumptions.*—The assumption (b) does not preclude a correction being made in an actual design to allow for the direct load-carrying capacity of the skins and the webs. The choice of the equivalent area to be added to the boom area will vary between one-sixth and one-half the wall area according to whether the wall is simply bent or is subjected to direct stress. In the case of a predominantly torsional loading the walls will be bent and the correction factor will be one-sixth, whereas under vertical bending loads the top and bottom skins will be fully effective and half their area will be added to each spar boom area.

It should be appreciated that a correction of one-half the skin area is not exact, for an error will be introduced in the chordwise bending stiffnesses of the top and bottom skins, and it will be seen later that these stiffnesses are of importance in formulating the strain energy function of the beam. The stress distribution obtained by the method will be most accurate when the boom areas are large compared with the effective area of the skins in reacting direct load.

The assumption (d) is significant in the determination of the boom direct loads in terms of λ_r and P ; if the ribs lie in a direction other than at right-angles to the spars, the rib moment, due to the transfer of load at the rib, will have a spanwise component, and the final reacting of this component at the spars would necessitate further assumptions and the evaluation of the strain energy in comparatively simple terms would be most difficult. The assumption that the ribs have only shear connection to the spars is significant at rib 1, where additional terms would be added to the strain-energy equation if rib bending moments in the plane of the rib were reacted directly at the rear spar root.

The assumption (e) would appear to be reasonable since transfer other than by the ribs would necessitate the skin having bending stiffness at right-angles to its plane.

4. *Load Transfer at a Rib.*—When the load λP is transferred from one spar to the other, the bending moment will be taken by the shear flows in the top and bottom skins of the box-beam as shown in Fig. 2; and the beam will be subject to the self-equilibrating system of loads as shown in Fig. 3.

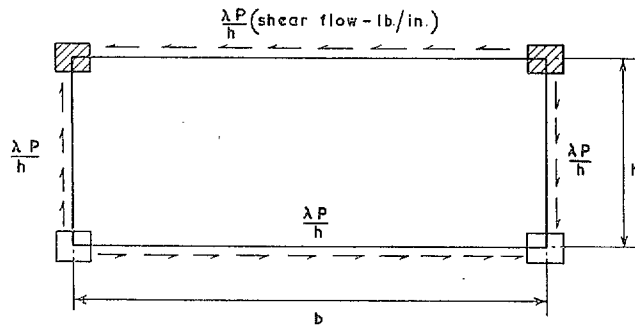

FIG. 2. Self-equilibrating system of loads at rib.

The handling of simultaneous equations, equal in number and variables to the number of ribs would obviously be unmanageable, and a compromise would be required. It is thought that 5 ribs (*i.e.*, 6 when the root rib is included) should give the load distribution with reasonable accuracy and also with reasonable computation. It would be advisable to leave rib 1 (*see* Fig. 3) as designed and replace the actual ribs by 4 ribs of equivalent total shear stiffness.

To retain a certain degree of generality the spar booms will not be considered uniform in area along the whole length of the beam, but varying in steps at each rib and being of uniform area in each bay.

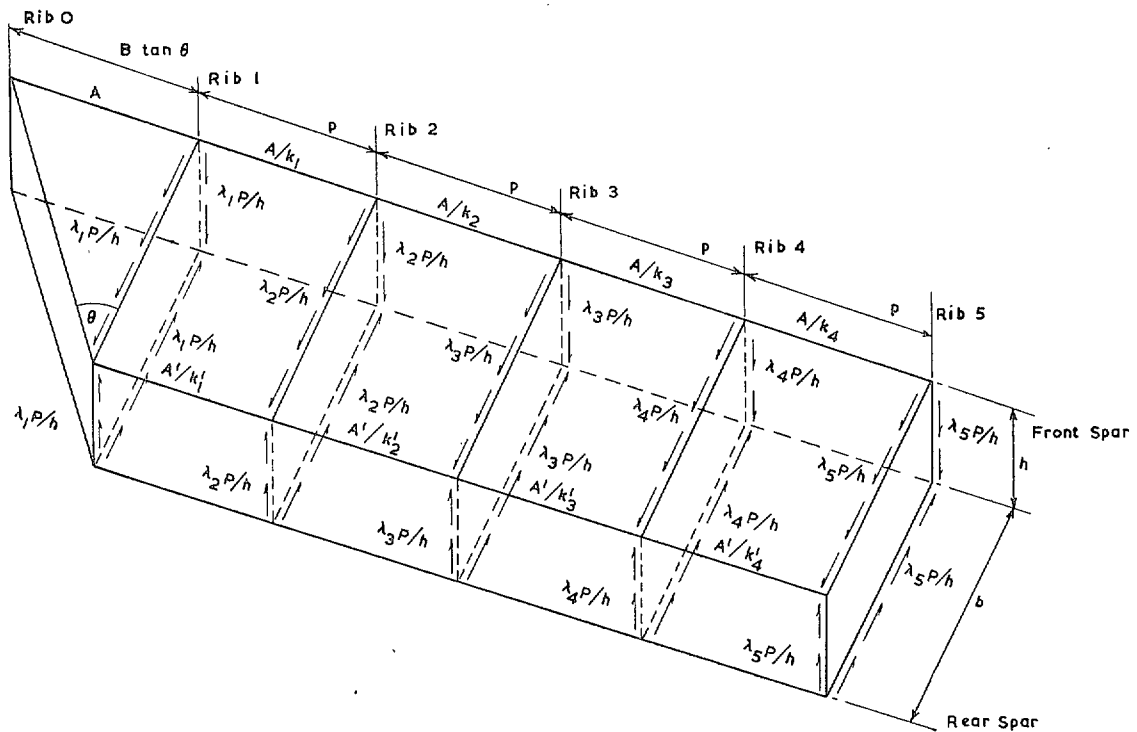

FIG. 3. Load distribution in box-beam.

It will be noted that Fig. 3 does not include an applied load, but it is convenient to obtain an expression for the strain energy of the beam under the system of loads as shown and introduce the effects of an applied load at a later stage in the analysis.

4.1. *Strain Energy of Direct Load in the Front Spar Booms.*—The rate of change of direct load in the booms is equal to the change of the shear flows in the adjacent skins, *i.e.*, Direct load in boom at distance x from rib 5 = $2(P/h)\lambda_5x$.

Therefore strain energy of boom between ribs 4 and 5

$$\begin{aligned} &= \frac{1}{2} \int_0^p (P/h)^2 (2\lambda_5)^2 \frac{k_4 x^2 dx}{AE} \\ &= \frac{k_4}{2AE} (P/h)^2 p^3 \{(2\lambda_5)^2/3\}. \end{aligned}$$

Direct load in boom at rib 4 = $2(P/h)\lambda_5 p$.

Therefore strain energy of boom between ribs 3 and 4

$$\begin{aligned} &= \frac{1}{2} \int_0^p (P/h)^2 \frac{k_3}{AE} \{2\lambda_5 p + (2\lambda_4 + 2\lambda_5)x\}^2 dx \\ &= \frac{1}{2} (P/h)^2 \frac{k_3}{AE} p^3 \{(2\lambda_5)^2 + (2\lambda_4 + 2\lambda_5)(2\lambda_5) + (2\lambda_4 + 2\lambda_5)^2/3\} \end{aligned}$$

and similarly for the other bays, except between rib 0 and rib 1 where the strain energy of the boom

$$\begin{aligned} &= \frac{1}{2} (P/h)^2 \frac{1}{AE} \int_0^{b \tan \theta} \{(2\lambda_2 + 4\lambda_3 + 6\lambda_4 + 8\lambda_5)p + (2\lambda_1 + 2\lambda_2 + 2\lambda_3 + 2\lambda_4 \\ &\quad + 2\lambda_5)x\}^2 dx \\ &= \frac{1}{2} (P/h)^2 \frac{p^3}{AE} \{2\lambda_2 + 4\lambda_3 + 6\lambda_4 + 8\lambda_5\}^2 z \\ &\quad + (2\lambda_2 + 4\lambda_3 + 6\lambda_4 + 8\lambda_5)(2\lambda_1 + 2\lambda_2 + 2\lambda_3 + 2\lambda_4 + 2\lambda_5)z^2 \\ &\quad + (2\lambda_1 + 2\lambda_2 + 2\lambda_3 + 2\lambda_4 + 2\lambda_5)^2 z^3/3 \} \end{aligned}$$

where $z = b \tan \theta / p$.

4.1.1. *Strain energy of direct load in the rear spar booms.*—In a similar manner the strain energy of the rear spar booms can be evaluated; a typical expression, for the boom between ribs 2 and 3 being

$$\begin{aligned} &= \frac{1}{2} (P/h)^2 \frac{p^3}{A'E} k'_2 \{(2\lambda_4 + 4\lambda_5)^2 + (2\lambda_4 + 4\lambda_5)(2\lambda_3 + 2\lambda_4 + 2\lambda_5) \\ &\quad + (2\lambda_3 + 2\lambda_4 + 2\lambda_5)^2/3\}. \end{aligned}$$

4.2. *Strain Energy of the Top and Bottom Skins in Shear.*—The shear stress in the top and bottom skins can be written as $(1/t_s)(\lambda_5)(P/h)$, $(1/t_s)(\lambda_4 + \lambda_5)(P/h)$, etc., and the strain energy of the panels will be $\frac{1}{2}(P/h)^2 b p / Gt_s (\lambda_4)^2$, etc., and for the triangular portion will be $\frac{1}{2}(P/h)^2 b p / Gt_s [(\lambda_1 + \lambda_2 + \lambda_3 + \lambda_4 + \lambda_5)^2 z / 2]$.

4.3. *Strain Energy of the Spar Webs in Shear.*—Similarly the strain energy of the spar webs in shear can be evaluated, a typical term which refers to the front spar web in the bay between ribs 2 and 3 will be

$$= \frac{1}{2} (P/h)^2 \frac{h p}{Gt_w} (\lambda_3 + \lambda_4 + \lambda_5)^2$$

and for the web between ribs 0 and 1 will be

$$= \frac{1}{2}(P/h)^2 \frac{h\phi}{Gt_w} (\lambda_1 + \lambda_2 + \lambda_3 + \lambda_4 + \lambda_5)^2 z.$$

4.4. *Strain Energy of the Ribs.*—Since the bending moment due to λP is progressively reacted by chordwise shears in the top and bottom skins there will be no bending moment in the rib and thus the contribution by the rib to the strain energy of the system will be that due to a uniform shear of P/h per unit length, *i.e.*,

$$\text{Strain energy of the rib} = \frac{1}{2}(P/h)^2 \frac{bh}{Gt_R} \lambda^2.$$

5. *Total Strain Energy of the Box-Beam.*—The total strain energy U of the system can be written from the above expressions as follows:—

$$\begin{aligned} U = & (P/h)^2 \frac{\phi^3}{AE} [k_4(2\lambda_5)^2/3 + k_3\{(2\lambda_5)^2 + (2\lambda_5)(2\lambda_4 + 2\lambda_5) + \frac{1}{3}(2\lambda_4 + 2\lambda_5)^2\} \\ & + k_2\{(2\lambda_4 + 4\lambda_5)^2 + (2\lambda_4 + 4\lambda_5)(2\lambda_3 + 2\lambda_4 + 2\lambda_5) + (2\lambda_3 + 2\lambda_4 + 2\lambda_5)^2/3\} \\ & + k_1\{(2\lambda_3 + 4\lambda_4 + 6\lambda_5)^2 + (2\lambda_3 + 4\lambda_4 + 6\lambda_5)(2\lambda_2 + 2\lambda_3 + 2\lambda_4 + 2\lambda_5) \\ & + (2\lambda_2 + 2\lambda_3 + 2\lambda_4 + 2\lambda_5)^2/3\} \\ & + \{(2\lambda_2 + 4\lambda_3 + 6\lambda_4 + 8\lambda_5)^2 z + (2\lambda_2 + 4\lambda_3 + 6\lambda_4 + 8\lambda_5)(2\lambda_1 + 2\lambda_2 + 2\lambda_3 + 2\lambda_4 + 2\lambda_5)z^2 \\ & + (2\lambda_1 + 2\lambda_2 + 2\lambda_3 + 2\lambda_4 + 2\lambda_5)^2 z/3\}] \\ & + (P/h)^2 \frac{\phi^3}{A'E} [k_4'(2\lambda_5)^2/3 + k_3'\{(2\lambda_5)^2 + (2\lambda_5)(2\lambda_4 + 2\lambda_5) + (2\lambda_4 + 2\lambda_5)^2/3\} \\ & + k_2'\{(2\lambda_4 + 4\lambda_5)^2 + (2\lambda_4 + 4\lambda_5)(2\lambda_3 + 2\lambda_4 + 2\lambda_5) + (2\lambda_3 + 2\lambda_4 + 2\lambda_5)^2/3\} \\ & + k_1'\{(2\lambda_3 + 4\lambda_4 + 6\lambda_5)^2 + (2\lambda_3 + 4\lambda_4 + 6\lambda_5)(2\lambda_2 + 2\lambda_3 + 2\lambda_4 + 2\lambda_5) \\ & + (2\lambda_2 + 2\lambda_3 + 2\lambda_4 + 2\lambda_5)^2/3\}] \\ & + \frac{1}{2}(P/h)^2 \frac{b\phi}{Gt_s} [\lambda_5^2 + (\lambda_4 + \lambda_5)^2 + (\lambda_3 + \lambda_4 + \lambda_5)^2 + (\lambda_2 + \lambda_3 + \lambda_4 + \lambda_5)^2 \\ & + (\lambda_1 + \lambda_2 + \lambda_3 + \lambda_4 + \lambda_5)^2 z/2] \\ & + \frac{1}{2}(P/h)^2 \frac{b\phi}{Gt_s'} [\lambda_5^2 + (\lambda_4 + \lambda_5)^2 + (\lambda_3 + \lambda_4 + \lambda_5)^2 + (\lambda_2 + \lambda_3 + \lambda_4 + \lambda_5)^2 \\ & + (\lambda_1 + \lambda_2 + \lambda_3 + \lambda_4 + \lambda_5)^2 z/2] \\ & + \frac{1}{2}(P/h)^2 \frac{h\phi}{Gt_w} [\lambda_5^2 + (\lambda_4 + \lambda_5)^2 + (\lambda_3 + \lambda_4 + \lambda_5)^2 + (\lambda_2 + \lambda_3 + \lambda_4 + \lambda_5)^2 \\ & + (\lambda_1 + \lambda_2 + \lambda_3 + \lambda_4 + \lambda_5)^2 z] \\ & + \frac{1}{2}(P/h)^2 \frac{h\phi}{Gt_w} [\lambda_5^2 + (\lambda_4 + \lambda_5)^2 + (\lambda_3 + \lambda_4 + \lambda_5)^2 + (\lambda_2 + \lambda_3 + \lambda_4 + \lambda_5)^2] \\ & + \frac{1}{2}(P/h)^2 \frac{hb}{Gt_R} [\alpha\lambda_1^2 + \lambda_2^2 + \lambda_3^2 + \lambda_4^2 + \lambda_5^2]. \end{aligned}$$

The above expression can be regarded as the 'general' expression for the strain energy of the box-beam. The first and second square brackets refer to the front and rear spar booms respectively, the third and fourth give the top and bottom-skin contributions, the fifth and sixth brackets give the contributions of the front and rear spar webs and the seventh bracket contains the contributions of the ribs.

The procedure adopted to obtain the strain energy for a load P applied on the front spar at rib r is to replace $2n\lambda_r$ by $(2n\lambda_r - n)$ and λ_r by $(\lambda_r - 1)$ in the front spar boom and front spar web contributions respectively, all other terms remaining as written in the general expression. Similarly when a load P is applied to the rear spar the general expression for the strain energy remains unaltered except $(2n\lambda_r - n)$ replaces $2n\lambda_r$ and $(\lambda_r - 1)$ replaces λ_r in the rear spar boom and web contributions respectively.

The strain energy, U , is minimised for $\lambda_1 \lambda_2 \dots \lambda_5$ and the equations $\partial U/\partial \lambda_r = 0$ [$r = 1, 2 \dots 5$] can be solved for $\lambda_1 \dots \lambda_5$. It will be realised that the replacing of $2\lambda_s$ by $(2\lambda_s - 1)$ will not affect the coefficients of λ_s in the equations $\partial U/\partial \lambda_r = 0$ and hence the coefficients of λ_s ($s = 1 \dots 5$) in the equations $\partial U/\partial \lambda_r = 0$ ($r = 1 \dots 5$) will be the same for all positions of the applied load. Thus the position of the applied load will only affect the constant term of the simultaneous equations; this feature will considerably reduce the computation involved in the solution of a box-beam under a system of distributed loads. Tables 1 and 2 give the coefficients and constant terms of the simultaneous equations.

6. *The Effect of a Cut-out in the Beam.*—A similar method of attack can be applied to determine the effect on the load distribution of a cut-out between two or more ribs in the top or bottom skin. In such a case no torque can be transferred to the root across the cut-out by shears in the top and bottom skins. This infers that the transfer at the outboard rib of the cut-out must neutralise the transfer that has been effected outboard of this rib. It will be noted that the satisfying of the following requirements will be automatic, *i.e.*,

- (a) The total vertical shear will equal the vertical loads applied outboard of the rib.
- (b) The moment of the front spar web shear about the rear spar will equal the moment of the loads applied outboard of the rib about the rear spar.

In general terms, if the outboard rib of the cut-out is the r th of the N ribs the condition to be satisfied is

$$\lambda_r = - \sum_{s=r+1}^N \lambda_s.$$

Substitution into the general strain-energy expression similar to section 5 will reduce the number of variables to $N - 1$, and the minimising of the function U with respect to λ_s ($S = 1, 2, r - 1, r + 1, N$) will give the necessary equations for the solution of the problem.

7. *The Effect of Flexibility at the Root.*—The strain-energy function has been formulated for encastred conditions at the root. Since the distribution in terms of load at the root is known it is not difficult to add extra terms to the general strain energy expression to include the effect of either axial load flexibility or shear load flexibility. It would be necessary to estimate the deflection due to unit load and obtain the strain energy due to this flexibility. The additional terms would be minimised with respect to λ_r ($r = 1$ to N) and incorporated in the coefficients and constants of the $\partial U/\partial \lambda_r = 0$ equations given in Tables 1 and 2.

8. *The Application of the Method to a Numerical Example.*—To illustrate the effects of sweep-back on the load distribution, a box-beam is considered for angles of sweep from 0 deg to 40 deg. The geometry of the beam is shown in Fig. 4a. The solution of the simultaneous equations when a load P is applied at each rib at the front and rear spars allows the transfer-coefficient table of Fig. 4b to be completed.

The substitution of the appropriate values of λ in the expressions of 4.1, 4.1.1, etc. determines the spar boom loads and the web shear loads for the various loading conditions.

Figs. 5 and 6 show the distribution of direct load in the booms for bending and torque loads respectively applied at rib 5. Figs. 7 and 8 show the spar web shear loads under similar conditions.

A check of the present method is obtained by comparing the distribution at zero sweep with that derived by Williams' method of R. & M. 1761.

8.1. *Remarks on the Results.*—Referring to Figs. 6, 9 and 10 it will be seen that the introduction of sweep into the box-beam affects the root constraint for torsional loading. For a torque applied at rib 5 the axial constraint boom loads at the rear-spar root are reduced, at 40 deg sweep, to 60 per cent of their value at zero sweep and furthermore the reduction is approximately linear with the angle of sweep. It is of interest to note, however, that the spar web shear loads, Fig. 8, are hardly affected at the root by the sweep, and at 40 deg sweep are still more than 90 per cent of their value at zero sweep.

Figs. 5 and 7 show that sweep also materially affects the distribution due to bending loads; when these loads are applied at rib 5, the rear-spar boom direct load is increased by more than 33 per cent for 40 deg of sweep, and the rear-spar web shear load is increased by approximately 50 per cent for 40 deg sweep. The front spar has corresponding decreases.

Fig. 11 is of interest in that it shows very good agreement, at zero sweep, with the distribution of direct load in the spar booms as calculated by Williams' method of R. & M. 1761. Williams' theory was based upon an assumption of 'rigid ribs of infinite number' and curve II is obtained by the present method with an assumption of infinitely stiff ribs.

The effect of the flexibility of the end rib (*i.e.*, rib 5) in the distribution of the spar boom loads is shown by the curves III and IV of Fig. 11. The torque is applied as differential shears to the webs at rib 5; and the flexibility of that rib will tend to produce larger differential shears in the webs inboard of rib 5 than those induced, by the root constraint effect, when the torque is applied as Batho shear.

9. *Conclusions.*—The effect of sweepback in a rectangular box-beam (no taper), with ribs perpendicular to the spars and in which the bending loads are taken by spar booms is considered. On the assumption that transfer of load between the spars can only be effected at the ribs, it is shown that the strain energy of the box-beam can be expressed in terms of the applied load, the box geometry and N variables (N being the number of ribs). The minimising of the strain-energy function with respect to each rib variable produces N linear simultaneous equations of N unknowns, the solution of which will give the load distribution in the beam.

It is considered that sufficient accuracy can be obtained by replacing the actual ribs with 5 ribs of equivalent shear stiffness, and tables are included in the report to enable the coefficients and constants of the 5 simultaneous equations to be quickly evaluated for encastred root conditions.

It is also indicated how the method can be adapted to include the effects of axial and/or shear flexibilities at the root. The problem of a cut-out in the top or bottom skin is also discussed and the load distribution in terms of the rib transfer coefficients for a typical case is included.

A numerical example is investigated and the transfer coefficients are included in the report. When a torsional loading is applied to the box-beam the direct loads in the spar booms at the root (assumed encastred in the example) are shown to be considerably reduced for large angles of sweep whereas the spar web shears at the root are not materially affected. For the same beam in bending there are significant changes of both spar boom and spar web loads at the root,

and as a consequence of the sweep-back the rear spar is more heavily loaded than the front spar. For the special case of zero sweepback a comparison is made with the distribution of load in the spar booms for a torsional loading obtained by the classical method of R. & M. 1761 and satisfactory agreement is obtained.

REFERENCES

<i>No.</i>	<i>Author</i>	<i>Title, etc.</i>
1	W. H. Wittrick	Preliminary analysis of a highly swept cylindrical tube under torsion and bending. A.C.A. 39. May, 1948.
2	E. H. Mansfield	Elasticity of a sheet reinforced by stringers and skew ribs, with applications to swept wings. R. & M. 2758. December, 1949.
3	W. S. Hemp	On the application of oblique co-ordinates to problems of plane elasticity and swept-back wings. R. & M. 2754. January, 1950.
4	D. Williams	The stresses in certain tubes of rectangular cross-section under torque. R. & M. 1761. May, 1936.

TABLE 1

Coefficients of λ Determinant $\left(C = (P/h)^2 \frac{p^3}{AE}, C' = (P/h)^2 \frac{p^3}{A'E}, D = \frac{1}{2}(P/h)^2 \frac{hp}{t_w G}, D' = \frac{1}{2}(P/h)^2 \frac{hp}{t'_w G} \right.$
 $\left. F = \frac{1}{2}(P/h)^2 \frac{bp}{t_s G}, F' = \frac{1}{2}(P/h)^2 \frac{bp}{t'_s G}, H = \frac{1}{2}(P/h)^2 \frac{bh}{t_r G} \right)$

10

λ_1	λ_2	λ_3	λ_4	λ_5	
$\frac{8}{3}Cz^3 + 2Dz$ $+ (F + F')z + 2H\alpha$	$4Cz^2 + \frac{8}{3}Cz^3 + 2Dz$ $+ (F + F')z$	$8Cz^2 + \frac{8}{3}Cz^3 + 2Dz$ $+ (F + F')z$	$12Cz^2 + \frac{8}{3}Cz^3 + 2Dz$ $+ (F + F')z$	$16Cz^2 + \frac{8}{3}Cz^3 + 2Dz$ $+ (F + F')z$	= R
$4Cz^2 + \frac{8}{3}Cz^3 + 2Dz$ $+ Fz + F'z$	$\frac{8}{3}Ck_1 + 8Cz + 8Cz^2$ $+ \frac{8}{3}Cz^3 + 2D + 2Dz$ $+ 2F + Fz + \frac{8}{3}C'k_1'$ $+ 2D' + 2H + 2F'$ $+ F'z$	$\frac{2^0}{3}Ck_1 + 16Cz$ $+ 12Cz^2 + \frac{8}{3}Cz^3 + 2D$ $+ 2Dz + 2F + Fz$ $+ \frac{2^0}{3}C'k_1' + 2D'$ $+ 2F' + F'z$	$\frac{3^2}{3}Ck_1 + 24Cz + 16Cz^2$ $+ \frac{8}{3}Cz^3 + 2D + 2Dz$ $+ 2F + Fz + \frac{3^2}{3}C'k_1'$ $+ 2D' + 2F' + F'z$	$\frac{4^4}{3}Ck_1 + 32Cz + 20Cz^2$ $+ \frac{8}{3}Cz^3 + 2D + 2Dz$ $+ 2F + Fz + \frac{4^4}{3}C'k_1'$ $+ 2D' + 2F' + F'z$	= S
$8Cz^2 + \frac{8}{3}Cz^3 + 2Dz$ $+ Fz + F'z$	$\frac{2^0}{3}Ck_1 + 16Cz$ $+ 12Cz^2 + \frac{8}{3}Cz^3$ $+ 2D + 2Dz + 2F$ $+ Fz + \frac{2^0}{3}C'k_1'$ $+ 2D' + 2F' + F'z$	$\frac{8}{3}Ck_2 + \frac{5^6}{3}Ck_1 + 32Cz$ $+ 16Cz^2 + \frac{8}{3}Cz^3 + 4D$ $+ 2Dz + 4F + Fz$ $+ \frac{8}{3}C'k_2' + \frac{5^6}{3}C'k_1'$ $+ 2H + 4D' + 4F'$ $+ F'z$	$\frac{2^0}{3}Ck_2 + \frac{9^2}{3}Ck_1 + 48Cz$ $+ 20Cz^2 + \frac{8}{3}Cz^3 + 4D$ $+ 2Dz + 4F + Fz$ $+ \frac{2^0}{3}C'k_2' + \frac{9^2}{3}C'k_1'$ $+ 4D' + 4F' + F'z$	$\frac{3^2}{3}Ck_2 + \frac{1^2 \cdot 8}{3}Ck_1$ $+ 64Cz + 24Cz^2$ $+ \frac{8}{3}Cz^3 + 4D + 2Dz$ $+ 4F + Fz + \frac{3^2}{3}C'k_2'$ $+ \frac{1^2 \cdot 8}{3}C'k_1' + 4D'$ $+ 4F' + F'z$	= T

TABLE 1—continued

11

λ_1	λ_2	λ_3	λ_4	λ_5	
$12Cz^2 + \frac{8}{3}Cz^3 + 2Dz$ $+ Fz + F'z$	$\frac{32}{3}Ck_1 + 24Cz$ $+ 16Cz^2 + \frac{8}{3}Cz^3$ $+ 2D + 2Dz + 2F$ $+ Fz + \frac{32}{3}C'k_1'$ $+ 2D' + 2F' + F'z$	$\frac{20}{3}Ck_2 + \frac{92}{3}Ck_1$ $+ 48Cz + 20Cz^2$ $+ \frac{8}{3}Cz^3 + 4D + 2Dz$ $+ 4F + Fz$ $+ \frac{20}{3}C'k_2' + \frac{92}{3}C'k_1'$ $+ 4D' + 4F' + F'z$	$\frac{8}{3}Ck^3 + \frac{56}{3}Ck_2$ $+ \frac{152}{3}Ck_1 + 72Cz$ $+ 24Cz^2 + \frac{8}{3}Cz^3$ $+ 6D + 2Dz + 6F$ $+ Fz + \frac{8}{3}C'k_3'$ $+ \frac{56}{3}C'k_2' + \frac{152}{3}C'k_1'$ $+ 2H + 6D' + 6F'$ $+ F'z$	$\frac{20}{3}Ck_3 + \frac{92}{3}Ck_2$ $+ \frac{212}{3}Ck_1 + 96Cz$ $+ 28Cz^2 + \frac{8}{3}Cz^3$ $+ 6D + 2Dz + 6F$ $+ Fz + \frac{20}{3}C'k_3'$ $+ \frac{92}{3}C'k_2' + \frac{212}{3}C'k_1'$ $+ 6D' + 6F' + F'z$	= U
$16Cz^2 + \frac{8}{3}Cz^3 + 2Dz$ $+ Fz + F'z$	$\frac{44}{3}Ck_1 + 32Cz$ $+ 20Cz^2 + \frac{8}{3}Cz^3$ $+ 2D + 2Dz + 2F$ $+ Fz + \frac{44}{3}C'k_1'$ $+ 2D' + 2F' + F'z$	$\frac{32}{3}Ck_2 + \frac{128}{3}Ck_1$ $+ 64Cz + 24Cz^2$ $+ \frac{8}{3}Cz^3 + 4D + 2Dz$ $+ 4F + Fz$ $+ \frac{32}{3}C'k_2' + \frac{128}{3}C'k_1'$ $+ 4D' + 4F' + F'z$	$\frac{20}{3}Ck_3 + \frac{92}{3}Ck_2$ $+ \frac{212}{3}Ck_1 + 96Cz$ $+ 28Cz^2 + \frac{8}{3}Cz^3$ $+ 6D + 2Dz + 6F$ $+ Fz + \frac{20}{3}C'k_3'$ $+ \frac{92}{3}C'k_2' + \frac{212}{3}C'k_1'$ $+ 6D' + 6F' + F'z$	$\frac{8}{3}Ck_4 + \frac{56}{3}Ck_3$ $+ \frac{152}{3}Ck_2 + \frac{296}{3}Ck_1$ $+ 128Cz + 32Cz^2$ $+ \frac{8}{3}Cz^3 + 8D + 2Dz$ $+ 8F + Fz + 2H$ $+ \frac{8}{3}C'k_4' + \frac{56}{3}C'k_3'$ $+ \frac{152}{3}C'k_2' + \frac{296}{3}C'k_1'$ $+ 8D' + 8F' + F'z$	= V

TABLE 2
Constant of λ Determinant

Load applied at	R	S	T	U	V
Rib 1 F/S	$\frac{4}{3}Cz^3 + 2Dz$	$2Cz^2 + \frac{4}{3}Cz^3 + 2Dz$	$4Cz^2 + \frac{4}{3}Cz^3 + 2Dz$	$6Cz^2 + \frac{4}{3}Cz^3 + 2Dz$	$8Cz^2 + \frac{4}{3}Cz^3 + 2Dz$
Rib 1 R/S	0	0	0	0	0
Rib 2 F/S	$2Cz^2 + \frac{4}{3}Cz^3 + 2Dz$	$\frac{4}{3}Ck_1 + 4Cz + 4Cz^2 + \frac{4}{3}Cz^3 + 2D + 2Dz$	$\frac{1}{3}^0Ck_1 + 8Cz + 6Cz^2 + \frac{4}{3}Cz^3 + 2D + 2Dz$	$\frac{1}{3}^6Ck_1 + 12Cz + 8Cz^2 + \frac{4}{3}Cz^3 + 2D + 2Dz$	$\frac{2}{3}^2Ck_1 + 16Cz + 10Cz^2 + \frac{4}{3}Cz^3 + 2D + 2Dz$
Rib 2 R/S	0	$\frac{4}{3}C'k_1' + 2D'$	$\frac{1}{3}^0C'k_1' + 2D'$	$\frac{1}{3}^6C'k_1' + 2D'$	$\frac{2}{3}^2C'k_1' + 2D'$
Rib 3 F/S	$4Cz^2 + \frac{4}{3}Cz^3 + 2Dz$	$\frac{1}{3}^0Ck_1 + 8Cz + 6Cz^2 + \frac{4}{3}Cz^3 + 2D + 2Dz$	$\frac{4}{3}Ck_2 + \frac{2}{3}^8Ck_1 + 16Cz + 8Cz^2 + \frac{4}{3}Cz^3 + 4D + 2Dz$	$\frac{1}{3}^0Ck_2 + \frac{4}{3}^6Ck_1 + 24Cz + 10Cz^2 + \frac{4}{3}Cz^3 + 4D + 2Dz$	$\frac{1}{3}^6Ck_2 + \frac{6}{3}^4Ck_1 + 32Cz + 12Cz^2 + \frac{4}{3}Cz^3 + 4D + 2Dz$
Rib 3 R/S	0	$\frac{1}{3}^0C'k_1' + 2D'$	$\frac{4}{3}C'k_2' + \frac{2}{3}^8C'k_1' + 4D'$	$\frac{1}{3}^0C'k_2' + \frac{4}{3}^6C'k_1' + 4D'$	$\frac{1}{3}^6C'k_2' + \frac{6}{3}^4C'k_1' + 4D'$

TABLE 2—continued

Load applied at	R	S	T	U	V
Rib 4 F/S	$6Cz^2 + \frac{4}{3}Cz^3 + 2Dz$	$\frac{16}{3}Ck_1 + 12Cz + 8Cz^2 + \frac{4}{3}Cz^3 + 2D + 2Dz$	$\frac{10}{3}Ck_2 + \frac{46}{3}Ck_1 + 24Cz + 10Cz^2 + \frac{4}{3}Cz^3 + 4D + 2Dz$	$\frac{4}{3}Ck_3 + \frac{28}{3}Ck_2 + \frac{76}{3}Ck_1 + 36Cz + 12Cz^2 + \frac{4}{3}Cz^3 + 6D + 2Dz$	$\frac{10}{3}Ck_3 + \frac{46}{3}Ck_2 + \frac{106}{3}Ck_1 + 48Cz + 14Cz^2 + \frac{4}{3}Cz^3 + 6D + 2Dz$
Rib 4 R/S	0	$\frac{16}{3}C'k_1' + 2D'$	$\frac{10}{3}C'k_2' + \frac{46}{3}C'k_1' + 4D'$	$\frac{4}{3}C'k_3' + \frac{28}{3}C'k_2' + \frac{76}{3}C'k_1' + 6D'$	$\frac{10}{3}C'k_3' + \frac{46}{3}C'k_2' + \frac{106}{3}C'k_1' + 6D'$
Rib 5 F/S	$8Cz^2 + \frac{4}{3}Cz^3 + 2Dz$	$\frac{22}{3}Ck_1 + 16Cz + 10Cz^2 + \frac{4}{3}Cz^3 + 2D + 2Dz$	$\frac{16}{3}Ck_2 + \frac{64}{3}Ck_1 + 32Cz + 12Cz^2 + \frac{4}{3}Cz^3 + 4D + 2Dz$	$\frac{10}{3}Ck_3 + \frac{46}{3}Ck_2 + \frac{106}{3}Ck_1 + 48Cz + 14Cz^2 + \frac{4}{3}Cz^3 + 6D + 2Dz$	$\frac{4}{3}Ck_4 + \frac{28}{3}Ck_3 + \frac{76}{3}Ck_2 + \frac{148}{3}Ck_1 + 64Cz + 16Cz^2 + \frac{4}{3}Cz^3 + 8D + 2Dz$
Rib 5 R/S	0	$\frac{22}{3}C'k_1' + 2D'$	$\frac{16}{3}C'k_2' + \frac{64}{3}C'k_1' + 4D'$	$\frac{10}{3}C'k_2' + \frac{46}{3}C'k_2' + \frac{106}{3}C'k_1' + 6D'$	$\frac{4}{3}C'k_4' + \frac{28}{3}C'k_3' + \frac{76}{3}C'k_2' + \frac{148}{3}Ck_1 + 8D'$

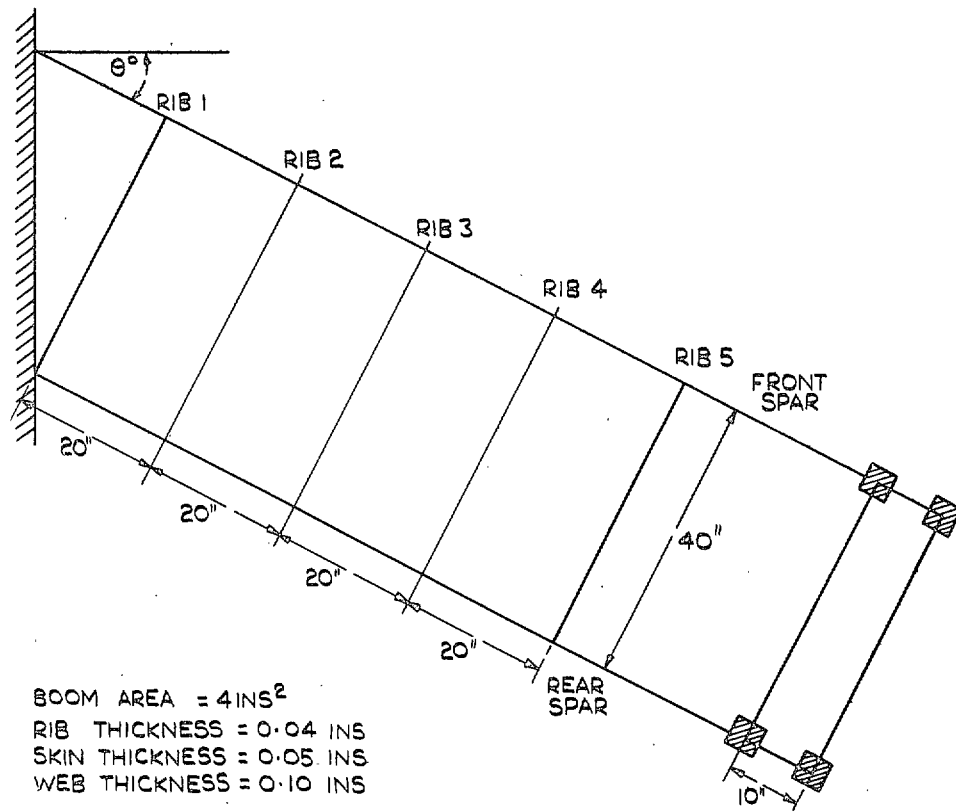

FIG. 4a. Geometry of box-beam in numerical example.

LOAD APPLIED AT	θ				
	λ_1	λ_2	λ_3	λ_4	λ_5
RIB 1 F.S.	---	---	---	---	---
RIB 1 R.S.	---	---	---	---	---
RIB 2 F.S.	0.0385	0.0385	0.0118	0.0046	0.0057
RIB 2 R.S.	0.0385	0.0385	0.0118	0.0046	0.0057
RIB 3 F.S.	0.0084	0.0084	0.0483	0.0211	0.0288
RIB 3 R.S.	0.0084	0.0084	0.0483	0.0211	0.0288
RIB 4 F.S.	0.0332	0.0332	0.0016	0.0609	0.0804
RIB 4 R.S.	0.0332	0.0332	0.0016	0.0609	0.0804
RIB 5 F.S.	0.0510	0.0510	0.0327	0.0142	0.1884
RIB 5 R.S.	0.0510	0.0510	0.0327	0.0142	0.1884
RIB 1 F.S.	---	---	---	---	---
RIB 1 R.S.	---	---	---	---	---
RIB 2 F.S.	0.0216	0.0490	0.0169	0.0074	0.0100
RIB 2 R.S.	0.0224	0.0329	0.0102	0.0040	0.0050
RIB 3 F.S.	0.0131	0.0051	0.0564	0.0259	0.0364
RIB 3 R.S.	0.0340	0.0185	0.0447	0.0196	0.0266
RIB 4 F.S.	0.0090	0.0164	0.0093	0.0674	0.0909
RIB 4 R.S.	0.0413	0.0475	0.0073	0.0582	0.0763
RIB 5 F.S.	0.0063	0.0307	0.0192	0.0224	0.2017
RIB 5 R.S.	0.0471	0.0693	0.0407	0.0102	0.1824
RIB 1 F.S.	0.0346	0.0140	0.0042	0.0016	0.0019
RIB 1 R.S.	---	---	---	---	---
RIB 2 F.S.	0.0298	0.0579	0.0223	0.0105	0.0150
RIB 2 R.S.	0.0325	0.0298	0.0091	0.0035	0.0043
RIB 3 F.S.	0.0199	0.0176	0.0644	0.0306	0.0441
RIB 3 R.S.	0.0502	0.0247	0.0421	0.0182	0.0246
RIB 4 F.S.	0.0161	0.0004	0.0197	0.0736	0.1010
RIB 4 R.S.	0.0613	0.0568	0.0117	0.0558	0.0728
RIB 5 F.S.	0.0142	0.0113	0.0064	0.0301	0.2142
RIB 5 R.S.	0.0715	0.0818	0.0469	0.0059	0.1772
RIB 1 F.S.	0.0826	0.0175	0.0101	0.0036	0.0041
RIB 1 R.S.	---	---	---	---	---
RIB 2 F.S.	0.1221	0.0396	0.0309	0.0145	0.0207
RIB 2 R.S.	0.0361	0.0212	0.0111	0.0035	0.0034
RIB 3 F.S.	0.0465	0.0252	0.0762	0.0358	0.0511
RIB 3 R.S.	0.0628	0.0223	0.0369	0.0067	0.0233
RIB 4 F.S.	0.0421	0.0136	0.0319	0.0798	0.1101
RIB 4 R.S.	0.0806	0.0488	0.0220	0.0530	0.0705
RIB 5 F.S.	0.0406	0.0076	0.0069	0.0372	0.2233
RIB 5 R.S.	0.0955	0.0698	0.0615	0.0027	0.1758
RIB 1 F.S.	0.1053	0.0339	0.0129	0.0060	0.0085
RIB 1 R.S.	---	---	---	---	---
RIB 2 F.S.	0.0755	0.0843	0.0361	0.0181	0.0269
RIB 2 R.S.	0.0433	0.0259	0.0074	0.0027	0.0031
RIB 3 F.S.	0.0648	0.0499	0.0824	0.0408	0.0603
RIB 3 R.S.	0.0676	0.0330	0.0380	0.0161	0.0215
RIB 4 F.S.	0.0817	0.0376	0.0416	0.0862	0.1211
RIB 4 R.S.	0.0842	0.0698	0.0185	0.0521	0.0669
RIB 5 F.S.	0.0611	0.0523	0.0193	0.0449	0.2380
RIB 5 R.S.	0.0982	0.0996	0.0566	0.0014	0.1685

FIG. 4b. Transfer coefficients for numerical example.

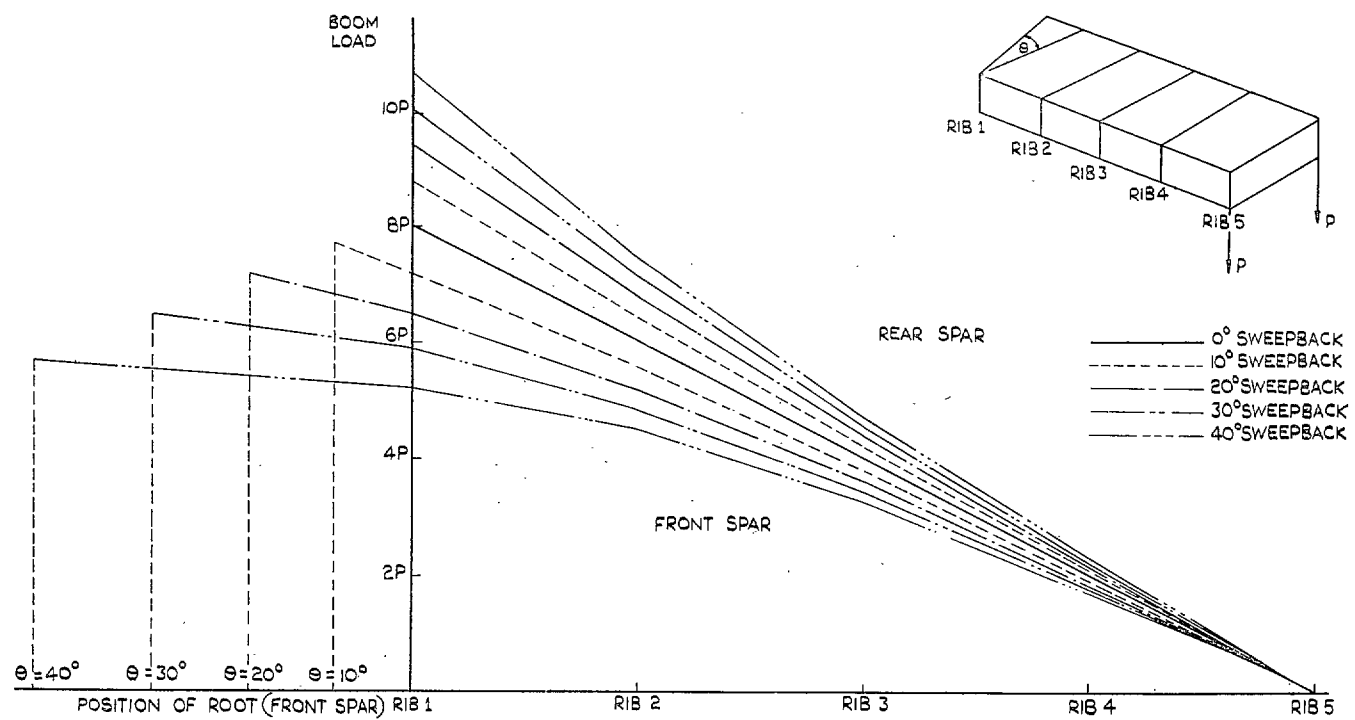

FIG. 5. Boom-loads. Bending loads applied at rib 5.

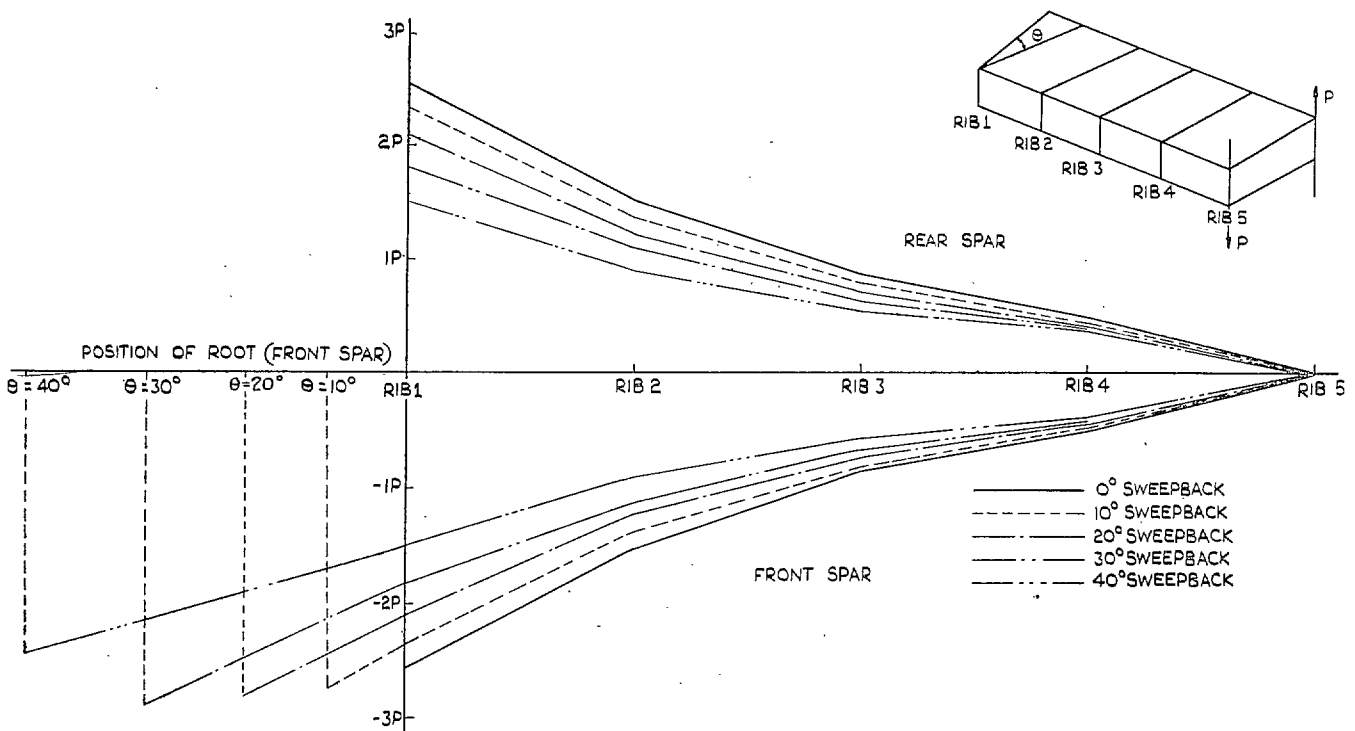

FIG. 6. Boom loads. Torsional loads applied at rib 5.

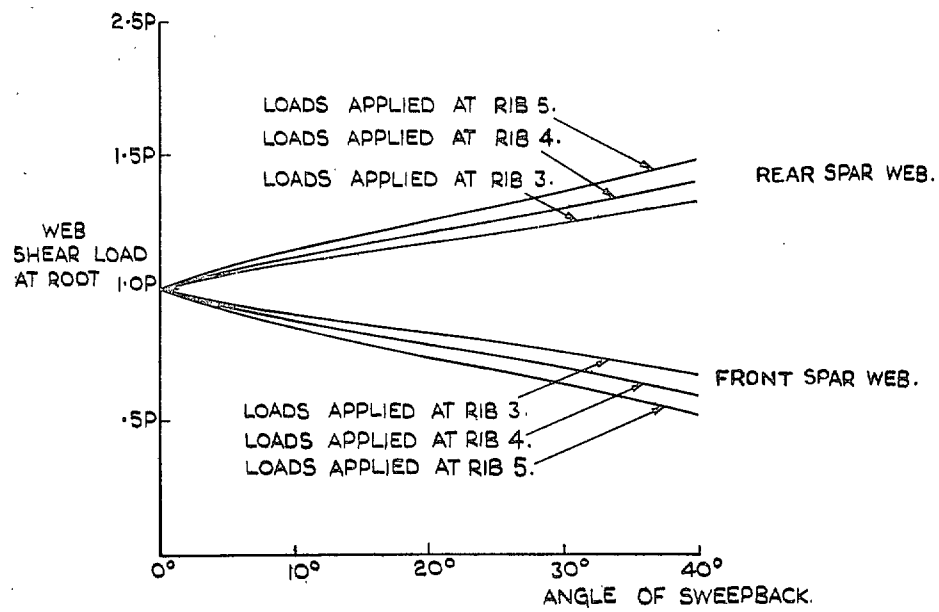

Fig. 7. Spar web loads at root due to bending loads.

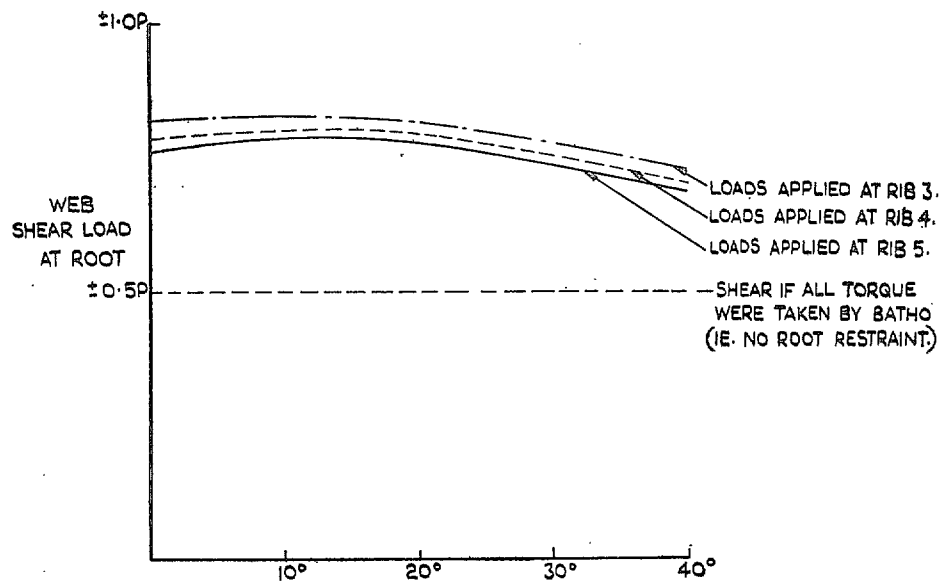

FIG. 8. Spar web loads at root due to torsional loads.

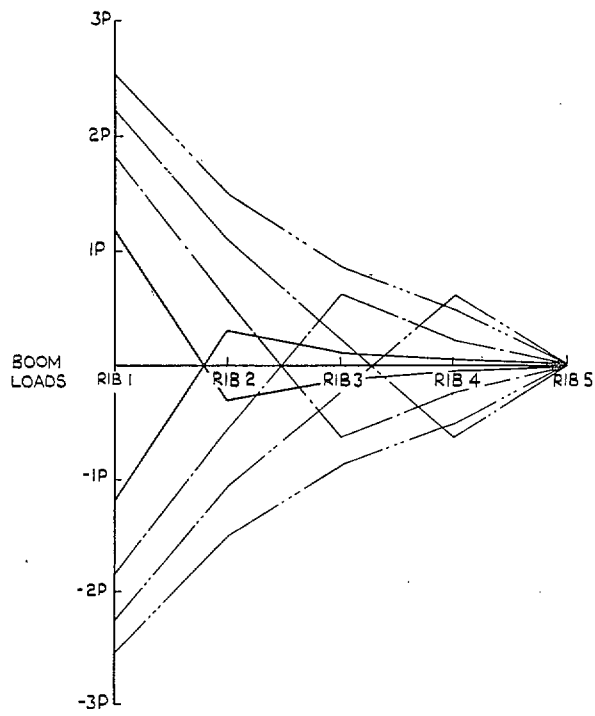

FIG. 9. Boom loads for equal torques applied at ribs 2, 3, 4 and 5. Zero sweep.

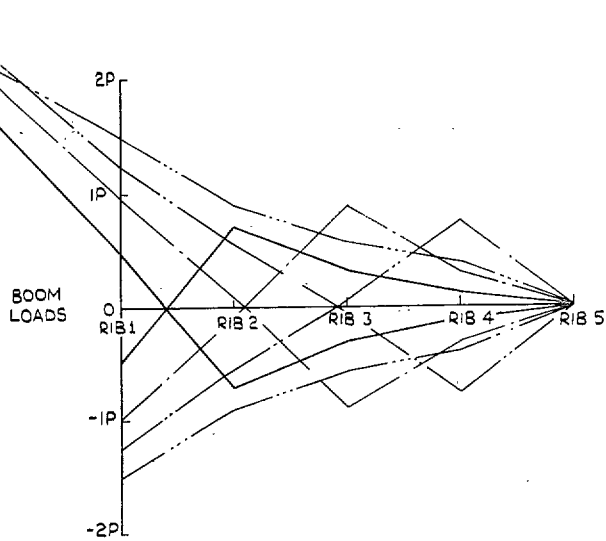

FIG. 10. Boom loads for equal torques applied at ribs 2, 3, 4 and 5. 40 deg sweep.

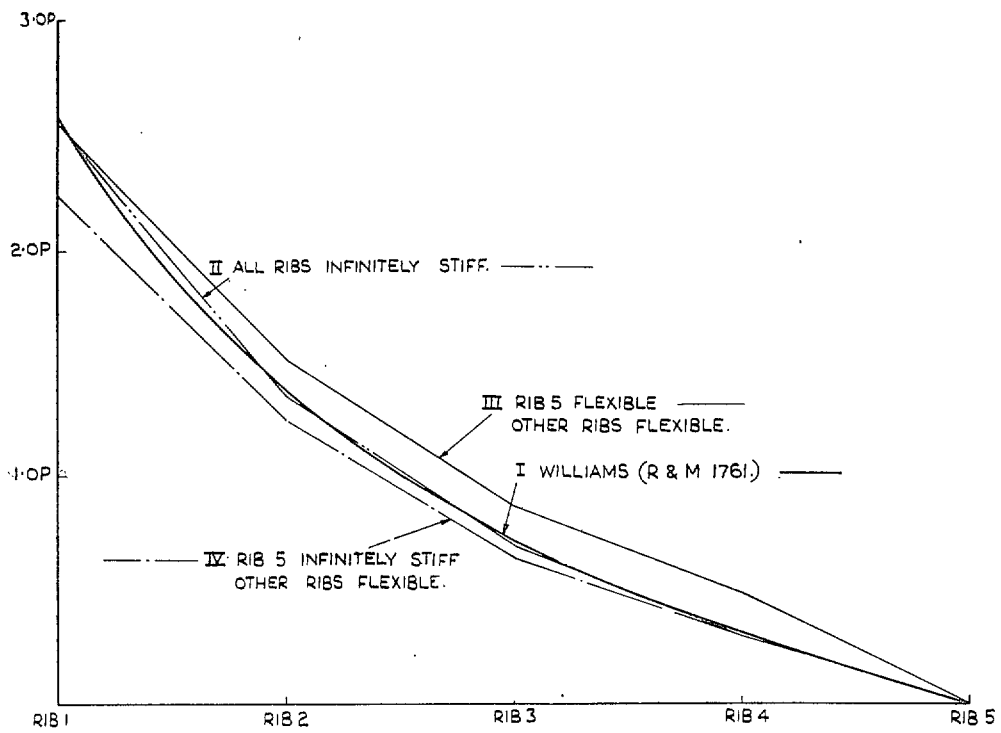

FIG. 11. A comparison with R. & M.1761 at zero sweepback of distribution in box-beam for torsional loading.

Publications of the Aeronautical Research Council

ANNUAL TECHNICAL REPORTS OF THE AERONAUTICAL RESEARCH COUNCIL (BOUND VOLUMES)

- 1936 Vol. I. Aerodynamics General, Performance, Airscrews, Flutter and Spinning. 40s. (41s. 1d.)
Vol. II. Stability and Control, Structures, Seaplanes, Engines, etc. 50s. (51s. 1d.)
- 1937 Vol. I. Aerodynamics General, Performance, Airscrews, Flutter and Spinning. 40s. (41s. 1d.)
Vol. II. Stability and Control, Structures, Seaplanes, Engines, etc. 60s. (61s. 1d.)
- 1938 Vol. I. Aerodynamics General, Performance, Airscrews. 50s. (51s. 1d.)
Vol. II. Stability and Control, Flutter, Structures, Seaplanes, Wind Tunnels, Materials. 30s. (31s. 1d.)
- 1939 Vol. I. Aerodynamics General, Performance, Airscrews, Engines. 50s. (51s. 1d.)
Vol. II. Stability and Control, Flutter and Vibration, Instruments, Structures, Seaplanes, etc. 63s. (64s. 2d.)
- 1940 Aero and Hydrodynamics, Aerofoils, Airscrews, Engines, Flutter, Icing, Stability and Control, Structures, and a miscellaneous section. 50s. (51s. 1d.)
- 1941 Aero and Hydrodynamics, Aerofoils, Airscrews, Engines, Flutter, Stability and Control, Structures. 63s. (64s. 2d.)
- 1942 Vol. I. Aero and Hydrodynamics, Aerofoils, Airscrews, Engines. 75s. (76s. 3d.)
Vol. II. Noise, Parachutes, Stability and Control, Structures, Vibration, Wind Tunnels. 47s. 6d. (48s. 7d.)
- 1943 Vol. I. Aerodynamics, Aerofoils, Airscrews, 80s. (81s. 4d.)
Vol. II. Engines, Flutter, Materials, Parachutes, Performance, Stability and Control, Structures. 90s. (91s. 6d.)
- 1944 Vol. I. Aero and Hydrodynamics, Aerofoils, Aircraft, Airscrews, Controls. 84s. (85s. 8d.)
Vol. II. Flutter and Vibration, Materials, Miscellaneous, Navigation, Parachutes, Performance, Plates, and Panels, Stability, Structures, Test Equipment, Wind Tunnels. 84s. (85s. 8d.)

ANNUAL REPORTS OF THE AERONAUTICAL RESEARCH COUNCIL—

1933-34	1s. 6d. (1s. 8d.)	1937	2s. (2s. 2d.)
1934-35	1s. 6d. (1s. 8d.)	1938	1s. 6d. (1s. 8d.)
April 1, 1935 to Dec. 31, 1936.	4s. (4s. 4d.)	1939-48	3s. (3s. 2d.)

INDEX TO ALL REPORTS AND MEMORANDA PUBLISHED IN THE ANNUAL TECHNICAL REPORTS, AND SEPARATELY—

April, 1950 - - - - R. & M. No. 2600. 2s. 6d. (2s. 7½d.)

AUTHOR INDEX TO ALL REPORTS AND MEMORANDA OF THE AERONAUTICAL RESEARCH COUNCIL—

1909-1949 - - - - R. & M. No. 2570. 15s. (15s. 3d.)

INDEXES TO THE TECHNICAL REPORTS OF THE AERONAUTICAL RESEARCH COUNCIL—

December 1, 1936 — June 30, 1939.	R. & M. No. 1850.	1s. 3d.	(1s. 4½d.)
July 1, 1939 — June 30, 1945.	R. & M. No. 1950.	1s.	(1s. 1½d.)
July 1, 1945 — June 30, 1946.	R. & M. No. 2050.	1s.	(1s. 1½d.)
July 1, 1946 — December 31, 1946.	R. & M. No. 2150.	1s. 3d.	(1s. 4½d.)
January 1, 1947 — June 30, 1947.	R. & M. No. 2250.	1s. 3d.	(1s. 4½d.)
July, 1951 - - - -	R. & M. No. 2350.	1s. 9d.	(1s. 10½d.)

Prices in brackets include postage.

Obtainable from

HER MAJESTY'S STATIONERY OFFICE

York House, Kingsway, London W.C.2 ; 423 Oxford Street, London W.1 (Post Orders : P.O. Box No. 569, London S.E.1) ;
13A Castle Street, Edinburgh 2 ; 39 King Street, Manchester 2 ; 2 Edmund Street, Birmingham 3 ; 1 St. Andrew's
Crescent, Cardiff ; Tower Lane, Bristol 1 ; 80 Chichester Street, Belfast OR THROUGH ANY BOOKSELLER