

N.A.R.

R. & M. No. 2775  
(12,737)  
A.R.C. Technical Report



MINISTRY OF SUPPLY

AERONAUTICAL RESEARCH COUNCIL  
REPORTS AND MEMORANDA

Stresses in Built-up Beams due to an Abrupt  
Change in Shear Stress at a Loading Station

*By*

J. TAYLOR, M.A.

*Crown Copyright Reserved*

LONDON: HER MAJESTY'S STATIONERY OFFICE

1953

FIVE SHILLINGS NET

# Stresses in Built-up Beams due to an Abrupt Change in Shear Stress at a Loading Section

By

J. TAYLOR, M.A.

COMMUNICATED BY THE PRINCIPAL DIRECTOR OF SCIENTIFIC RESEARCH (AIR),  
MINISTRY OF SUPPLY

---

*Reports and Memoranda No. 2775\**

*August, 1949*

---

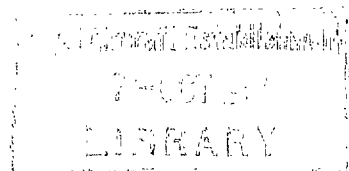

*Summary.*—Owing to the abrupt change in shear stress at loading sections of beams there is a concentration of direct stress in the outer fibres of the beam near the loading section. A method of calculating this concentration is described. The highest stress concentrations occur in short deep beams and are greater for wooden than metal beams.

The method is applied to the spars of two wooden aircraft and stress concentrations 1.06 and 1.4 are found at the fuselage attachments.

Strain measurements were made at positions on a wooden beam under load and the theoretical predictions verified.

---

## NOTATION

- $a$  Depth of each flange of beam  
 $a_1, a_2$  Depth of each flange of beam if different  
 $b$  Width of flange of beam  
 $h$  Distance of centre of each flange from centre of inertia of section  
 $h_1, h_2$  Distance of centre of each flange from centre of inertia of section if different  
 $l$  Semi-length of beam  
 $A$  Area of each flange  
 $A_1, A_2$  Area of each flange if different  
 $A_w$  Total web area, web assumed to end at inner edge of flange  
 $B$  Bending stiffness of flange =  $\frac{1}{12} a^2 \cdot A \cdot E$   
 $C$  Shear stiffness of web =  $G \cdot A_w$   
 $E$  Young's modulus of flange  
 $E_w$  Young's modulus of web in longitudinal direction  
 $G$  Shear modulus of web

---

\* R.A.E. Report Structures 48, received 25th November, 1949.

- $I_F$  Moment of inertia of flanges about neutral axis of beam  
 $I_w$  Moment of inertia of web about neutral axis of beam  
 $I$  Moment of inertia of complete section of beam  
 $Z$  Modulus of section of beam  
 $Z_B$  Modulus of section of flange  
 $x, y$  Co-ordinates measured along and across the beam  
 $u, v$  Displacements of web in directions  $x, y$  (when transverse strains are neglected  $v$  is constant across each section  $x$ )  
 $v_0$  Value of  $v$  at centre-line of web  
 $w$  Displacement of flange in direction  $y$  relative to the centre-line of the web  
 $W$  Load in direction  $y$  which is equal to the change in shear across loading section  
 $M$  Bending moment at loading section  
 $S(x)$  Shear load at a section  $x$   
 $p_b$  Bending stress at section on engineers' theory  
 $p_s$  Change in shear stress at loading  
 $m$  Bending moment in flange additional to St. Venant's solution

$$p = \sqrt{\frac{C}{2B}}$$

$$\lambda = \frac{3}{4} \cdot \frac{p_{s \max}}{p_{b \max}} \cdot \frac{E}{G}$$

1. *Introduction.*—The stresses at a section of a built-up beam, consisting of flanges connected by a web or webs, are normally calculated on the engineers' theory that stresses due to bending are independent of stresses due to shear. The bending strains are compatible with plane sections of the beam remaining plane whereas the shear strains require warping of the sections.

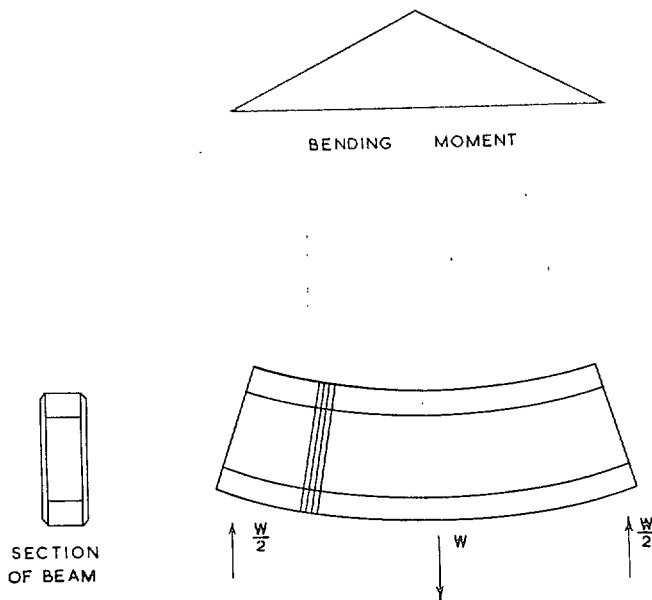

FIG. 1. Bending distortion of beams.

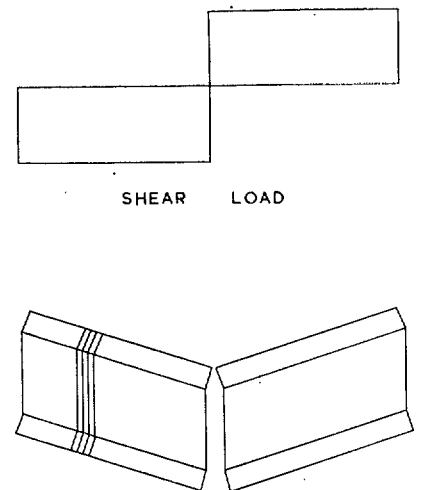

FIG. 2. Shear distortion of beams.

The distortion of a beam under three-point loading is shown in Figs. 1 and 2, the bending and shear distortions being treated separately. The shear distortion, being different on the two sections adjacent to the change in shear, would require a break in the beam and this is clearly impossible. From symmetry the section will remain plane at the change in shear and the flange will distort locally.

A method is described whereby this local stress concentration can be calculated. It is assumed that all the bending loads are reacted by end loads in the flanges and that the shear stress in the web is uniform across each section.

The effect of transverse strains is shown to be small and if it is neglected a complete solution can be obtained from the shear equation (equation (1))

$$\frac{C}{1 - a/2h} \left( \frac{du}{dy} + \frac{dv}{dx} \right) - 2B \frac{d^3v}{dx^3} = S.$$

The method is applied to determine the stress concentration in the spars of two types of wooden aircraft at the fuselage attachments.

2. *Basic Assumptions.*—To obtain the stress distribution at a section of a beam the following conditions must be fulfilled:—

- (i) the sum of the vertical shear loads in the web and flanges is equal to the total vertical shear at that section as determined from statical equilibrium.
- (ii) there is continuity of longitudinal displacement at the junctions of web and flanges.

A rigorous solution is not practicable for the distribution near concentrated vertical loads and the following simplifying assumptions are made:—

- (a) all the bending moment is reacted by end loads in the flanges.
- (b) the shear stress in the web is uniform across each section, there is continuity of shear load at the junction of the web and flanges and the shear stress in the flange, other than that due to local bending, reduces linearly to zero at the outer fibres.
- (c) each section of the flange remains plane under load.
- (d) there is no shear deflection of the flange at the loading section, *i.e.*, the shear stiffness of the flange is very large compared with the shear stiffness of the web.
- (e) transverse strains are neglected.

No appreciable error is liable to be introduced by assumptions (a) and (b). Assumption (c) means that the calculated stress at the outer fibres near the loaded section are lower than the actual stress but assumption (d) means that the calculated stress is higher. The effect due to (d) will be greater than that due to (c) and the calculated stresses are on the safe side. It is thought that this margin will be only a few per cent even where each flange has a shear stiffness as low as that of the web. The effect of transverse strains\* is shown to be negligible in Appendix I.

3. *Basic Equations.*—For a beam with equal tension and compression flanges the condition (i) may be written (*see* notation) as

Total vertical shear  $S = \{\text{shear load in web}\} + 2\{\text{shear load in each flange}\}$

$$= \left\{ C \left( \frac{du}{dy} + \frac{dv}{dx} \right) \right\} + 2 \left\{ -B \frac{d^3v}{dx^3} + C \frac{a/2}{2h - a} \left( \frac{du}{dy} + \frac{dv}{dx} \right) \right\}.$$

---

\* The transverse stresses are of course appreciable being essential for applying local transverse forces to the flanges.

This equation simplifies immediately to

$$\frac{C}{1 - \frac{a}{2h}} \left( \frac{du}{dy} + \frac{dv}{dx} \right) - 2B \frac{d^3v}{dx^3} = S \quad \dots \dots \dots (1)$$

A second equation is obtained from the equation for longitudinal stress in the web, making use of condition (ii). The longitudinal stress in the web is  $E \frac{du}{dx}$  and is proportional to its distance from the centre-line. Thus

$$E \frac{du}{dx} = \frac{y}{h - \frac{a}{2}} \left\{ \text{longitudinal stress at junction of web and flanges} \right\}.$$

By taking due account of the local bending moment  $\left( B \frac{d^2v}{dx^2} \right)$  in each flange the longitudinal stress in the flange, at the junction with the web, can be shown to be

$$-\frac{M}{2hA} + \left( \frac{B}{hA} + \frac{Ea}{2} \right) \frac{d^2v}{dx^2}.$$

Thus 
$$E \frac{du}{dx} = \frac{y}{h - \frac{a}{2}} \left\{ -\frac{M}{2hA} + \left( \frac{B}{hA} + \frac{Ea}{2} \right) \frac{d^2v}{dx^2} \right\}.$$

By integrating with respect to  $x$  and differentiating with respect to  $y$  the equation becomes

$$E \frac{du}{dy} = \frac{1}{h - \frac{a}{2}} \left\{ -\frac{1}{2hA} \int M dx + \left( \frac{B}{hA} + \frac{Ea}{2} \right) \frac{dv}{dx} \right\} + \text{constant} \quad \dots \dots (2)$$

By eliminating  $du/dy$  between equations (1) and (2) a linear differential equation with constant coefficients is obtained for  $v$  in terms of  $x$ . The method is applied to several special cases. A detailed solution for a cantilever is given in section 4 and the results for two other cases are given in sections 5 and 6.

4. *Cantilever or Beam under 3-point Loading.*—The solution of the equations (1) and (2) for a beam of length  $2l$  under a concentrated load  $W$  at its centre, or a cantilever of length  $l$  and a load  $W/2$  at its end, is based on the following boundary conditions

$$\begin{aligned} \frac{dv}{dx} &= 0 \quad \text{at } x = 0 \\ \frac{d^2v}{dx^2} &= 0 \quad \text{at } x = l, \end{aligned}$$

where  $x$  is measured from the encastré end of the cantilever or from the centre of the beam. The boundary condition  $\frac{dv}{dx} = 0$  at  $x = 0$  is a consequence of assumption (d) of section 2.

Putting  $S = \frac{W}{2}$  and  $M = \frac{W}{2} = (l - x)$ , equations (1) and (2) reduce to

$$\frac{C}{1 - \frac{a}{2h}} \left( \frac{du}{dy} + \frac{dv}{dx} \right) - 2B \frac{d^3v}{dx^3} = \frac{W}{2} \quad \dots \dots \dots (3)$$

$$E \frac{du}{dy} = \frac{1}{h - \frac{a}{2}} \left\{ -\frac{W}{4hA} \left( lx - \frac{x^2}{2} \right) + \left( \frac{B}{hA} + \frac{Ea}{2} \right) \frac{dv}{dx} \right\} \dots \dots \dots (4)$$

Eliminating  $\frac{du}{dy}$  between (3) and (4),

$$C \cdot \frac{1 + \frac{B}{Eh^2A}}{\left(1 - \frac{a}{2h}\right)^2} \cdot \frac{dv}{dx} - 2B \frac{d^2v}{dx^2} = \frac{W}{2} \left\{ 1 + \frac{C}{E} \frac{1}{2h^2A \left(1 - \frac{a}{2h}\right)^2} \left( lx - \frac{x^2}{2} \right) \right\} \dots \dots (5)$$

Hence

$$v = \frac{W}{2C} \left[ \left(1 - \frac{2B}{EI}\right)^2 \left(1 - \frac{a}{2h}\right)^2 \left( x + \frac{1}{p} e^{-px} \right) + \frac{C}{EI} \left( \frac{lx^2}{2} - \frac{x^3}{6} \right) \right] \dots \dots (6)$$

(where  $p^2 = \frac{C}{2B} \cdot \frac{1 + \frac{B}{Eh^2A}}{\left(1 - \frac{a}{2h}\right)^2}$  and  $e^{-pl}$  is negligible).

The local bending moment in the flange is  $B \frac{d^2v}{dx^2}$

$$= \frac{B}{EI} (l - x) \frac{W}{2} + \frac{BW}{2C} \cdot \left(1 - \frac{2B}{EI}\right)^2 \left(1 - \frac{a}{2h}\right)^2 p e^{-px} \dots \dots (7)$$

The first term is that given by the engineers' theory of bending and the second term is the concentration due to the presence of the loading section.

5. *Beam under 4-point Loading.*—The boundary conditions for a beam of length  $2l$  under two equal loads  $W$  at its ends and balanced by loads at equal distances  $b$  from the centre are

$$\frac{dv}{dx} = 0 \quad \text{at } x = 0$$

$$\frac{dv}{dx}, \frac{d^2v}{dx^2} \quad \text{continuous at } x = b$$

$$\frac{d^2v}{dx^2} = 0 \quad \text{at } x = l.$$

Under such conditions

$$m = \frac{BW}{2C} \left(1 - \frac{2B}{EI}\right)^2 \left(1 - \frac{a}{2h}\right)^2 \left\{ p e^{-p(x-b)} + p e^{-p(x+b)} \right\} \quad \text{for } x < b$$

and

$$m = \frac{BW}{2C} \left(1 - \frac{2B}{EI}\right)^2 \left(1 - \frac{a}{2h}\right)^2 \left\{ p e^{-p(x-b)} \left(1 + e^{-2pb}\right) \right\} \quad \text{for } x > b \dots \dots (8)$$

(where  $e^{-pb}$  is neglected).

6. *Any Single Abrupt Change of Shear.*—There is a stress concentration at any abrupt change of shear across a section of a beam and it may be proved generally that

$$m = \frac{B}{2C} W \left(1 - \frac{2B}{EI}\right)^2 \left(1 - \frac{a}{2h}\right)^2 p e^{-px} \quad \dots \quad \dots \quad \dots \quad \dots \quad (9)$$

$$\left( \text{where } p^2 = \frac{C}{2B} \frac{1 + \frac{B}{Eh^2A}}{\left(1 - \frac{a}{2h}\right)^2} \right)$$

provided there is no other abrupt change in shear in the neighbourhood.

The stress concentration at the outer fibres of the beam will be given by

$$\left( \frac{M}{Z} - \frac{2m}{2hA} + \frac{m}{Z_B} \right) / \frac{M}{Z}$$

which reduces to

$$\left[ 1 + \left\{ \left( \frac{3}{4} \frac{p_s}{p_b} \cdot \frac{E}{G} \right) \cdot h \frac{W}{M} \cdot \left( 1 - \frac{4}{3} \frac{a}{h} + \frac{1}{9} \frac{a^2}{h^2} \right) \right\}^{1/2} \right] \quad \dots \quad \dots \quad \dots \quad (10)$$

(neglecting  $(a/h)^3$  terms) .

The amount by which the stress concentration factor exceeds unity will reduce to 1/e of its maximum value at a distance  $1/p$  from the abrupt change of shear. For wooden or metal spars  $1/p$  will be equal to about once or twice the depth of the spar flange.

Provided the bending moment in each flange is small compared with the total bending moment the stress concentration for beams with unequal flanges can be calculated by putting  $(a_1 + a_2)/2$  for  $a$ ,  $(h_1 + h_2)/2$  for  $h$  and  $h_1 W/M$  for  $hW/M$  in equation (10).

The stress concentration is only of interest when  $p_b$  is large and it is greatest when  $p_s$  is equal to twice the ultimate shear stress, that is when there is a change of shear from ultimate stress in one direction to ultimate stress in the opposite direction. For a beam of given section this maximum stress concentration can be predicted as follows:—

- (i) The maximum value of the first term under the square root sign in equation (10) can be obtained from the constants of the material and is  $\lambda$  (say).
- (ii) The third term is less than unity but nearly equal to unity for deep beams.
- (iii) The stress concentration will thus be not greater than

$$1 + (\lambda hW/M)^{1/2} . \quad \dots \quad \dots \quad \dots \quad \dots \quad \dots \quad \dots \quad (11)$$

7. *Experimental Verification of Theory.*—Tests were made by Mr. A. J. Fairclough on wooden beams to check the theory and are described in Appendix II. The experiments were arranged so that the stress concentration at the outer fibres exceeded two. Using values of the elastic moduli as determined on the particular specimens, the measured strains in the flanges agree with those predicted theoretically.

8. *Practical Application of Results.*—Equation (11) states that the stress concentration is not greater than  $1 + (\lambda hW/M)^{1/2}$ . The value of  $\lambda$  is approximately 1 for metals, 4 for wood in cross-grain shear and 2 for wood in diagonal shear;  $hW/M$  is largest for short deep beams. The rate of die-away is less for wooden than metal spars being approximately inversely proportional to the flange depth.

The stress concentration will probably be significant only in structures made from non-ductile materials. The stresses in the main spars of two wooden aircraft in the neighbourhood of the abrupt change in shear at the connection to the fuselage have been calculated and are given in Table 1 and Fig. 3.

9. *Conclusions.*—Calculations on simple engineer's theory predict shear distortions which are incompatible at the sections of a beam adjacent to a concentrated load; the additional local bending moments to ensure compatibility are determined from considerations of shear equilibrium, the effects of transverse strains being shown to be negligible.

The stress at the outer fibres of a beam with shallow flanges will exceed the stress calculated on simple engineer's theory by a factor which has a maximum value at the loaded section of

$$1 + \left\{ \left( \frac{3}{4} \frac{p_s}{p_b} \cdot \frac{E}{G} \right) \left( h \frac{W}{M} \right) \right\}^{1/2}.$$

If account is taken of the finite depth of the flanges this maximum value of the factor will be reduced slightly. The additional stresses reduce exponentially with distance from the loaded section to 1/e times the maximum at a distance from the loaded section of once or twice the spar flange depth.

The maximum value  $\frac{3}{4} \frac{p_s}{p_b} \cdot \frac{E}{G}$  can attain will be greater for wood than metals and for a given  $\frac{3}{4} \frac{p_s}{p_b} \cdot \frac{E}{G}$  the maximum stress concentration will occur in deep beams (*i.e.*,  $hW/M$  large).

A calculation based on the dimensions of an aircraft wooden spar of deep section gave a stress concentration of 1.4. This is probably an extreme case for conventional designs but may be sufficient to cause premature failure in non-ductile materials.

---

## APPENDIX I

### *Effect of Transverse Strains*

As in section 2 assume that the bending loads are reacted as end loads in the flanges of the beam and the shear loads are reacted by uniform shear stress in the web. It will now be assumed that the beam is not stiff transversely but for ease of computation the effect of transverse strain will be calculated for beams which are stiff in bending.

As the beam is stiff in bending the shear in the web is  $C \frac{dv_0}{dx}$  where  $C$  is the shear stiffness of web. The local bending in the flange produces a shear of

$$- B \frac{d^3}{dx^3} (v_0 + w) + C \frac{a/2}{2h - a} \frac{dv_0}{dx}.$$

The total shear in the section is  $S$  so that the shear equation becomes

$$\frac{1}{1 - a/2h} C \frac{dv_0}{dx} - 2B \frac{d^3}{dx^3} (v_0 + w) = S. \quad \dots \quad (12)$$





If the shear is all taken in the web

$$B \frac{d^2(v_0 + w)}{dx^2} = \frac{Bp_1}{C} \frac{W}{2} \left\{ \frac{e^{-p_1 x} - \frac{p_1}{p_2^3} e^{-p_2 x}}{1 - \frac{p_1}{p_2}} \right\} \left(1 - \frac{a}{2h}\right) \quad \dots \dots \dots (15)$$

To determine the effect of transverse strain equations (14) and (15) have to be compared with the equation to which equation (9) reduces when the beam is stiff in bending, *i.e.*,

$$m = \frac{Bp}{2C} W \left(1 - \frac{a}{2h}\right) e^{-px} \text{ where } p^2 = \frac{C}{2B} \cdot \frac{1}{1 - a/2h} \quad \dots \dots \dots (16)$$

For most conventional types of beam  $p_1/p_2$  will be small so that equations (14) and (15) will not differ much from equation (16) and the effect of transverse strain will be small.

---

## APPENDIX II

### *Experimental Investigation*

A.1. *Introduction.*—In order to test the accuracy of the theoretical solution, given in the text of this report, for the stresses caused by concentrated shear loads applied to built-up beams, a specimen was built up and tested under various loading conditions. The test specimen, which was made of wood since it is in non-ductile materials that the effects predicted in the text of this report are most pronounced, was a deep, narrow box-beam.

This specimen was tested over two different test lengths under the 3-point loading case and strains were measured with electrical resistance strain-gauges. Two different test lengths were used to give different ratios of bending to shear and consequently different stress concentrations.

A knowledge of the values of Young's and the shear moduli is necessary before the experimental strains can be translated into stresses. A separate set of experiments was, therefore, carried out to determine these values.

A.2. *Description of Specimen.*—The test specimen was built up from two three-ply birch webs,  $6 \times 3/16$  in., and two spruce flanges,  $1\frac{1}{4} \times \frac{3}{4}$  in., into a box-beam,  $6 \times 1\frac{5}{8} \times 50$  in. The loads were applied to the web through 10-s.w.g. mild steel distributing plates glued to the webs. Full constructional details of the specimen are given in Figs. 4 and 5.

A.3. *Strain-Gauge Installation.*—British Thermostat  $\frac{1}{2}$  in. self-adhesive type wire resistance strain-gauges were installed at 104 positions on the webs and flanges of the test specimen as described in Fig. 6.

A.4. *Description of Tests.*—Four tests were carried out on the specimen, two to determine Young's and the shear moduli for the materials of the specimen and two, with different unsupported lengths, to check the theory given in this report.

A.4.1. *Tension Test.*—The specimen was suspended from point A (*see* Fig. 6) and a dead-weight load of 3200 lb was applied at point B in increments of 400 lb. At each load readings were taken of the tensile strains in both flanges. The results of this test are given in Fig. 9. From the gauge readings the mean strain was found to be  $0.48 \times 10^{-3}$ .

A.4.2. *Pure Bending Test.*—In this test the beam was supported horizontally from points A and B (see Fig. 6) and loaded with equal loads at points C and D. The maximum load applied was 800 lb at each point. The central part CD of the beam is then in pure bending. In Fig. 7 the specimen is shown rigged for this test. Loads of 800 lb were applied at C and D in increments of 100 lb and measurements of direct strain in both flanges were taken at each load. The strain-gauge results are given in Fig. 10. The mean numerical value of the maximum fibre strain was  $0.868 \times 10^{-3}$ .

A.4.3. *Tests under 3-point Loading.*—Two tests were made under 3-point loading. The beam was loaded with a single concentrated load applied at E and supported horizontally, in the first tests at A and B and in the second at C and D (see Fig. 6). Strain-gauge readings were taken in both tests of the direct strains in both flanges and, in the first test, of shear strains in the webs. In the first test with the beam supported at points A and B a load of 1400 lb was applied at E in increments of 140 lb and strain-gauge readings were taken at each load. In the second test with the beam supported at points C and D a load of 1920 lb was applied at E in increments of 240 lb and strain-gauge readings were taken at each load. Fig. 8 shows the beam specimen rigged for the three-point loading test supported at points A and B.

A.5. *Determination of Young's and Shear Moduli.*—A.5.1. *Young's Modulus.*—The test specimen was made from two different woods—spruce and birch ply—and these two woods have different values of  $E$ . The result of the tension and pure bending tests were used to determine the values of  $E$  for these materials.

From the tension test  $L = (AE + A_w E_w) \text{ strain};$

From the pure bending test  $M' = (I_f E + I_w E_w) \frac{\text{strain at } y}{y},$

where  $L$  is the applied tension load in the tension test and  $M'$  is the applied bending moment in the bending test.

Substituting numerical values in these two equations (see Figs. 5, 9, 10) and solving for  $E$  and  $E_w$ ,

$$E = 1.78 \times 10^6 \text{ lb/sq in.}$$

$$E_w = 1.47 \times 10^6 \text{ lb/sq in.}$$

A.5.2. *Shear Modulus.*—The stress distribution predicted theoretically in this report depends upon the shear stiffness,  $C$ , of the webs of the beam. The records of shear strain obtained during the first test described in section A.4.3 above were used to obtain a value for  $C$ .

The shear equation for the beam is

$$\frac{C}{1 - a/2h} \left( \frac{du}{dy} + \frac{dv}{dx} \right) - 2B \frac{d^3v}{dx^3} = S \quad \dots \dots \dots (1 \text{ bis})$$

and away from abrupt changes of shear we may write,

$$(EI_f + E_w I_w) \frac{d^3v}{dx^3} = S.$$

Therefore equation (1) becomes

$$\frac{C}{1 - a/2h} \left( \frac{du}{dy} + \frac{dv}{dx} \right) - 2B \frac{S}{(EI_f + E_w I_w)} = S.$$

From readings taken in the first test mentioned in section A.4.3 a value of  $1.85 \times 10^{-3}$  was obtained for the shear strain in the webs of the beam under a shear force of 700 lb. We therefore have  $\left(\frac{du}{dy} + \frac{dv}{dx}\right) = 1.85 \times 10^{-3}$  and substituting this and all other relevant numerical values in the equation above,  $C$  is obtained as

$$C = 0.326 \times 10^6.$$

$A_w$  is assumed to be 1.69 in.<sup>2</sup> (see Fig. 5) and therefore the shear modulus,  $G = 1.93 \times 10^5$ .

A.6. *Experimental and Theoretical Results.*—Using the experimental values for  $E$  and  $C$  in the expressions of section 4 we obtain

$$p = 1.482.$$

For 1 lb centre load

$$m = 1.104e^{-1.482x}.$$

In Figs. 11 and 12 the theoretical stress distributions are shown for the 3-point loading tests with the beam supported at (C and D) and (A and B) respectively. The values of stress obtained from the strain-gauge readings using the experimental value of  $E$  are also shown in these figures.

Two theoretical distributions, assuming the beam encastré at two different points, are shown for the outer faces of the beam flanges. It would normally be assumed that the beam is effectively encastré at its centre (*i.e.*, on the line of action of the applied shear). There are, however, two steel load-distributing plates attached to the webs at the centre of the beam (see Fig. 4) to apply the external load into the webs. The ratio  $\frac{E_{\text{steel}}}{E_{\text{beam}}} \simeq 20$ , and taking the thickness of wood equivalent to a given thickness of steel as this ratio multiplied by the thickness of steel we find that the stiffness of the beam is more than doubled by the presence of the steel plates. It is therefore thought to be more realistic to assume that the beam is effectively encastré at the edge of the distributing plate (*i.e.*,  $\frac{1}{2}$  in. from the centre of the beam) and for this reason the stress distributions on this assumption are shown in Figs. 11 and 12.

It can be seen from Figs. 11 and 12 that the experimental points agree well with the theoretical stress distribution obtained assuming the beam to be effectively encastré at the edge of the load distributing plate.

It should be noted, however, that this agreement does not extend right up to the edge of the load distributing plate. The experimental curve rounds off to an appreciably lower value of stress than that predicted theoretically at the edge of the plate; this is due to the stiffening effect on the flanges of the presence of the distributing plates. The percentage theoretical over-estimate of stress will depend upon the magnitude of the stress concentration; this in turn depends upon the materials and dimensions of the beam.

In practical constructions of the same type as the test specimen used in these tests some form of distributing plate will always be present to put the concentrated shear load into the webs of the beam and there will be some smoothing of the actual stress distribution as noted above.

A.7. *Conclusions.*—The experiments described above show that the theoretical solution given in this report, gives a good estimate of the stresses induced in the flanges of a box-beam which is subjected to a concentrated shear force except close to any load distributing plates which are attached to the webs of the beam. They further show that close to such plates the theoretical solution gives an over-estimate of the stresses, the amount of the over-estimate depending upon the dimensions of the beam and the values of Young's and the shear moduli for the materials of the beam.

TABLE 1

Dimensions	Type A	Type B
$a_1$	5.25 in.	5.05 in.
$a_2$	3.4 in.	4.5 in.
$h_1$	7.35 in.	5.94 in.
$h_2$	11.35 in.	6.66 in.
$b$	4.625 in.	11.0 in. (effective thickness to give stresses of $p_b, p_s$ as below)
$t$	0.25 in.	0.25 in.
$M$	1,750,000 lb/in.	2,570,000 lb/in.
$W$	17,700 lb	9,050 lb
$p_b$	5,120 lb/sq in.	5,000 lb/sq in.
$p_s$	2,460 lb/sq in.	2,310 lb/sq in. (presuming both webs of spars have same shear stress)
$E$	$1.9 \times 10^6$ lb/sq in.	$1.9 \times 10^6$ lb/sq in.
$G$	$0.15 \times 10^6$ lb/sq in.	$0.6 \times 10^6$ lb/sq in.
$1/p$	9.83 in.	10.03 in.
Maximum bending stress	7,220 lb/sq in. ( $= 1.41 p_b$ )	5,275 lb/sq in. ( $= 1.05 p_b$ )

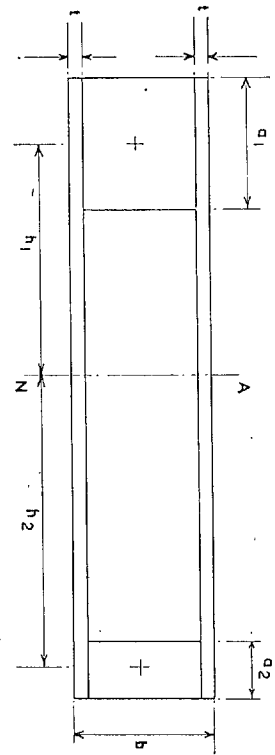

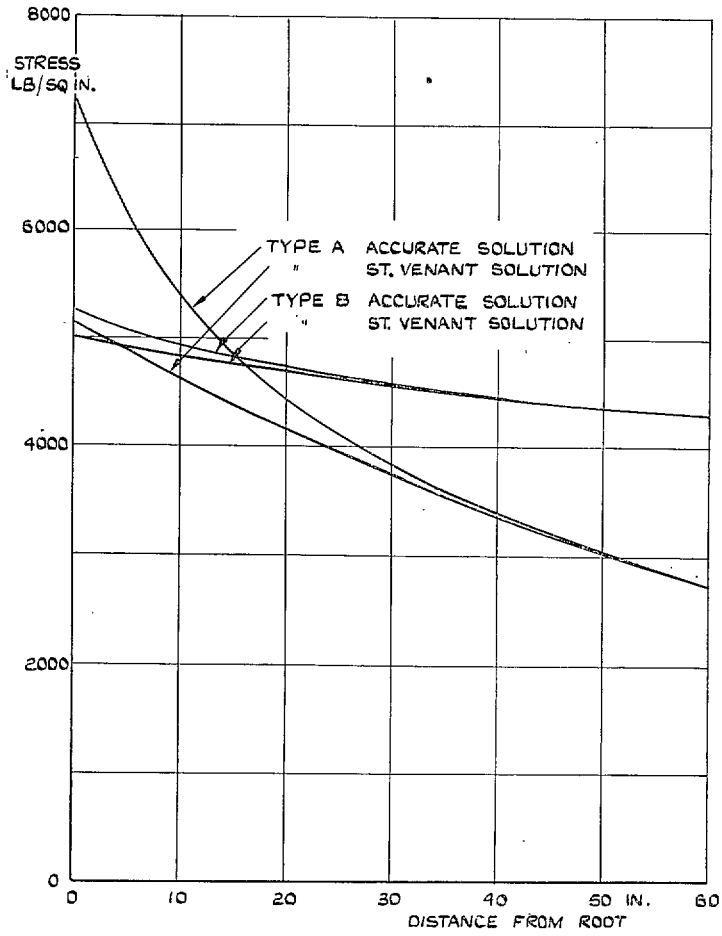

FIG. 3. Compression stress in outer fibres of spar.

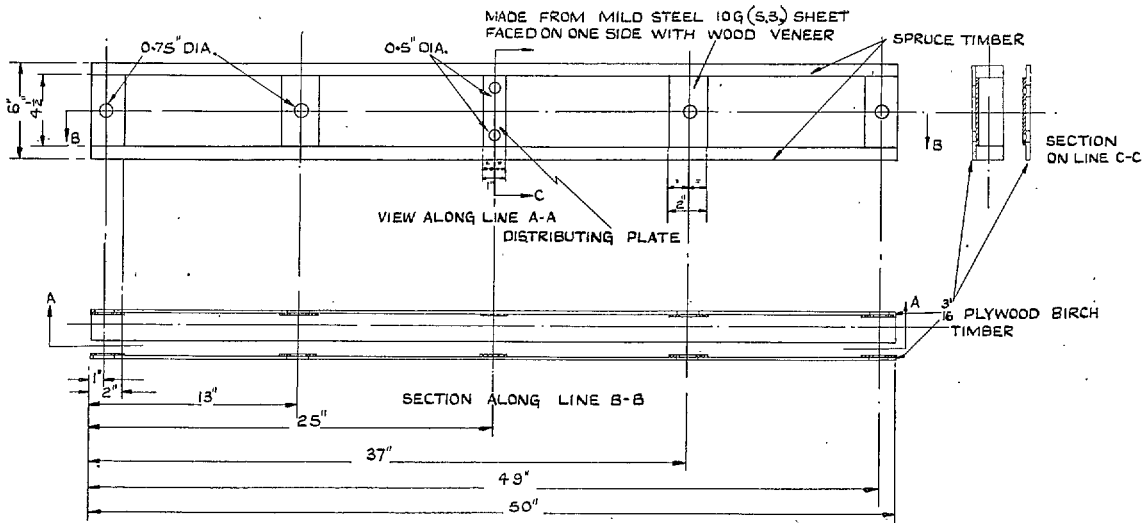
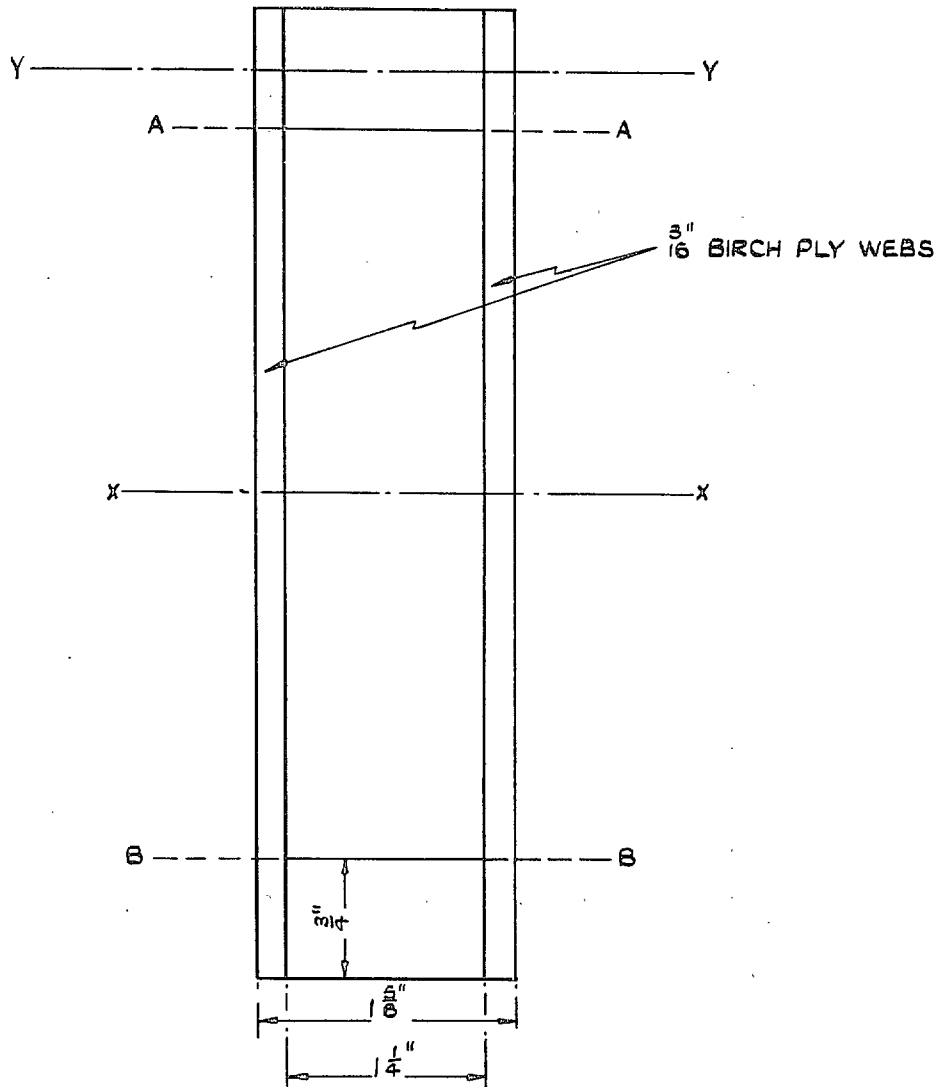

FIG. 4. Construction of test beam.



ASSUMING A FLANGE TO CONSIST OF THE  $1\frac{1}{4} \times \frac{3}{4}$  SPRUCE MEMBER ONLY  
WE OBTAIN:-

$$A = 1.875 \text{ IN.}^2$$

$$A_w = 2.25 \text{ IN.}^2$$

$$\text{TOTAL AREA OF SECTION} = 4.125 \text{ IN.}^2$$

$$(I_F)_{YY} = 13.00 \text{ IN.}^4$$

$$(I_w)_{XX} = 6.75 \text{ IN.}^4$$

$$(I)_{XX} = 19.75 \text{ IN.}^4$$

FOR THE PURPOSE OF CALCULATING B&C MATERIAL FURTHER FROM X-X THAN SECTIONS A-A AND B-B IS ASSUMED TO BE FLANGE MATERIAL WITH A UNIFORM VALUE OF YOUNG'S MODULUS; MATERIAL BETWEEN A-A & B-B IS ASSUMED TO BE WEB MATERIAL  
THUS, FOR THIS PURPOSE  $(I_F)_{YY} = 0.0572 \text{ IN.}^4$

$$\text{AND } B = E(I_F)_{YY} = 1.018 \times 10^5 \text{ LB IN.}^2$$

$$\text{ALSO } A_w = 1.69 \text{ IN.}^2$$

FIG. 5. Cross-section and section constants of test beam.

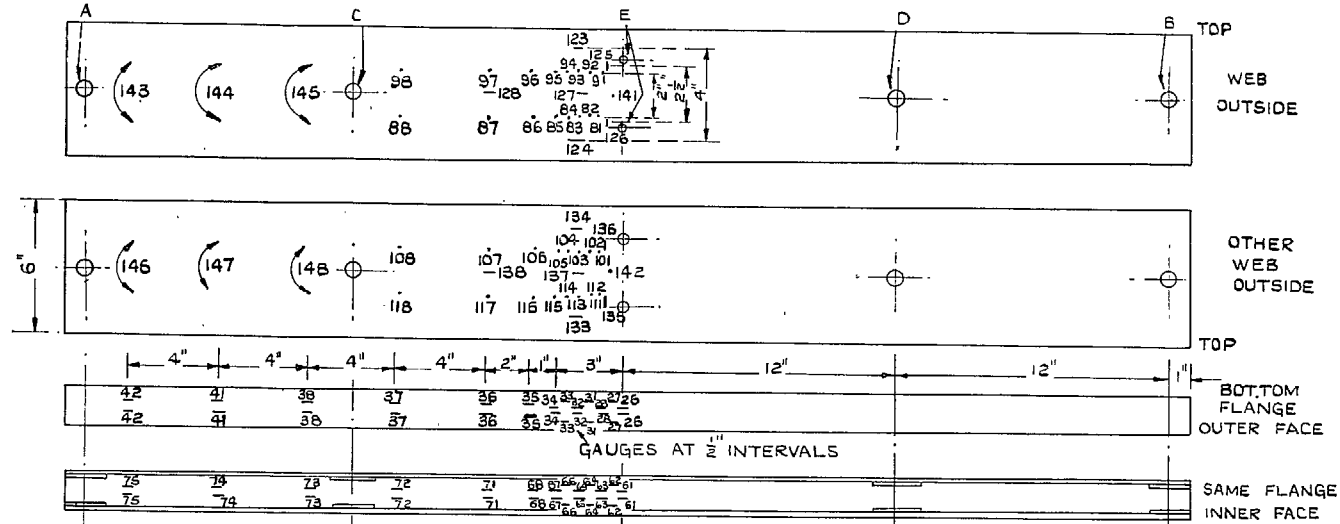

NOTE:-

- INDICATES 4 PAIRS OF GAUGES WIRED IN SERIES FROM INSIDE AND OUTSIDE OF SPECIMEN
- INDICATES A SINGLE END LOAD GAUGE
- INDICATES SHEAR GAUGE
- GAUGE NUMBERS RUN 11-18; 21-28; 31-38 ETC.

ALL POSITIONS ON THE WEBS CONSIST OF GAUGES ATTACHED TO BOTH SIDES OF THE WEB MATERIAL AND WIRED IN SERIES. END LOAD GAUGES BEARING THE SAME NUMBER ARE WIRED IN SERIES

THE OTHER FLANGE HAS GAUGES 11-28 & 43-57 SIMILARLY PLACED

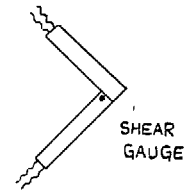

SHEAR GAUGE

FIG. 6. Strain-gauge installation on test beam.



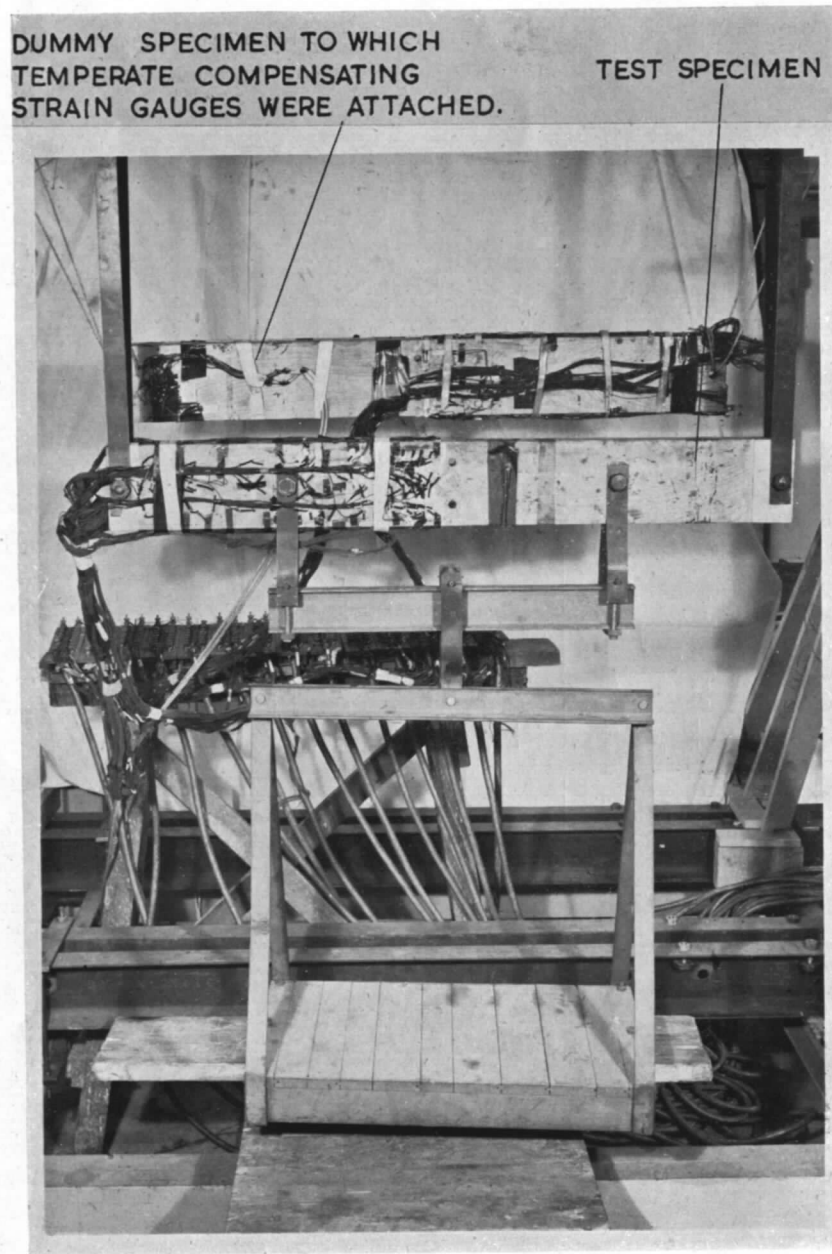

FIG. 7. Specimen rigged for pure bending test.

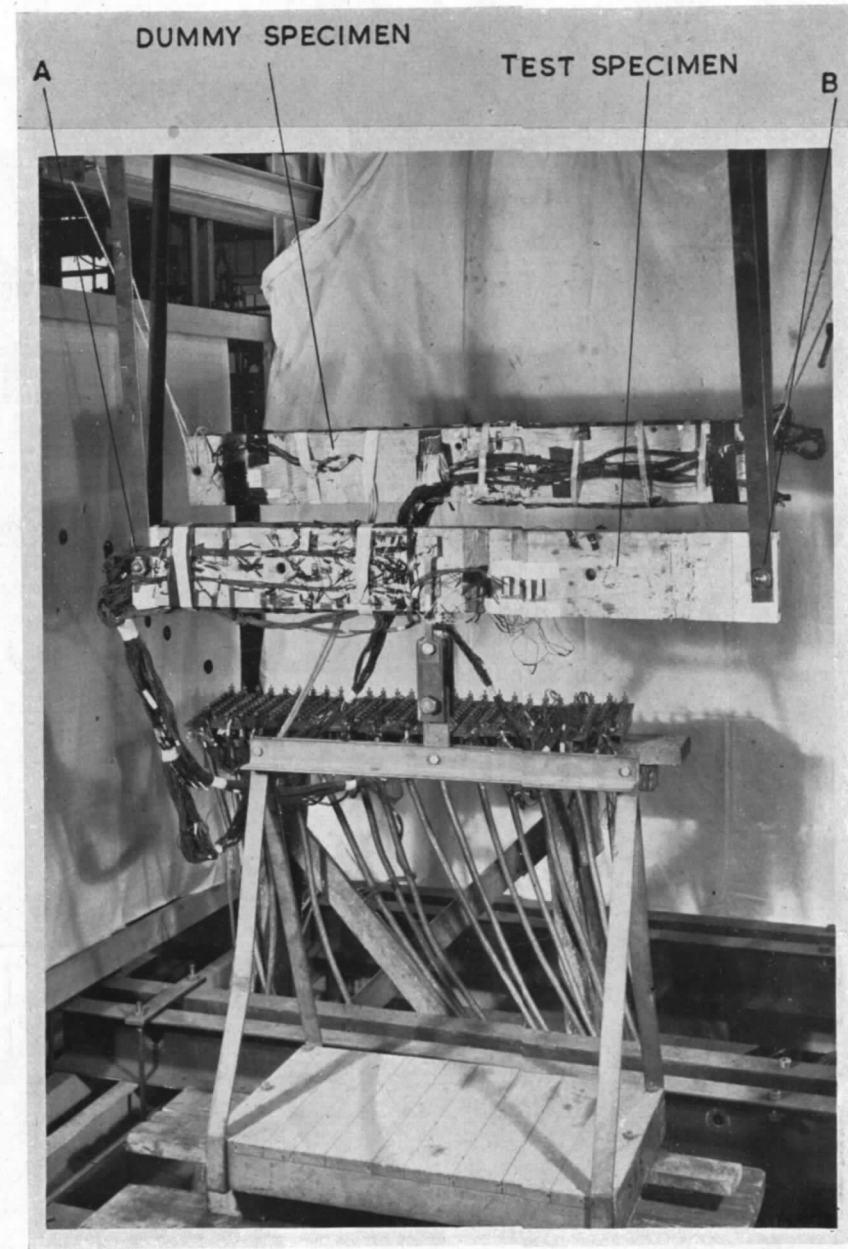

FIG. 8. Specimen rigged for 3-point loading test. Supports at A and B.

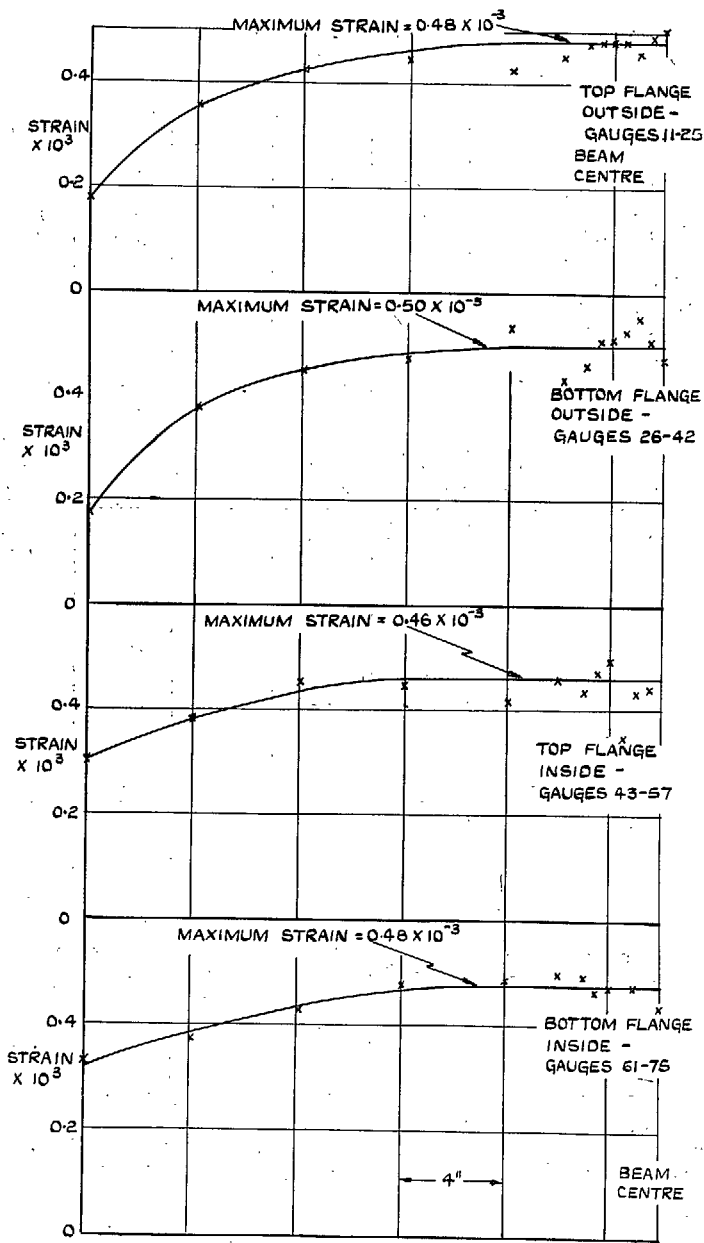

FIG. 9. Strain-gauge results in tension test. Readings at 3,200 lb tension.

17

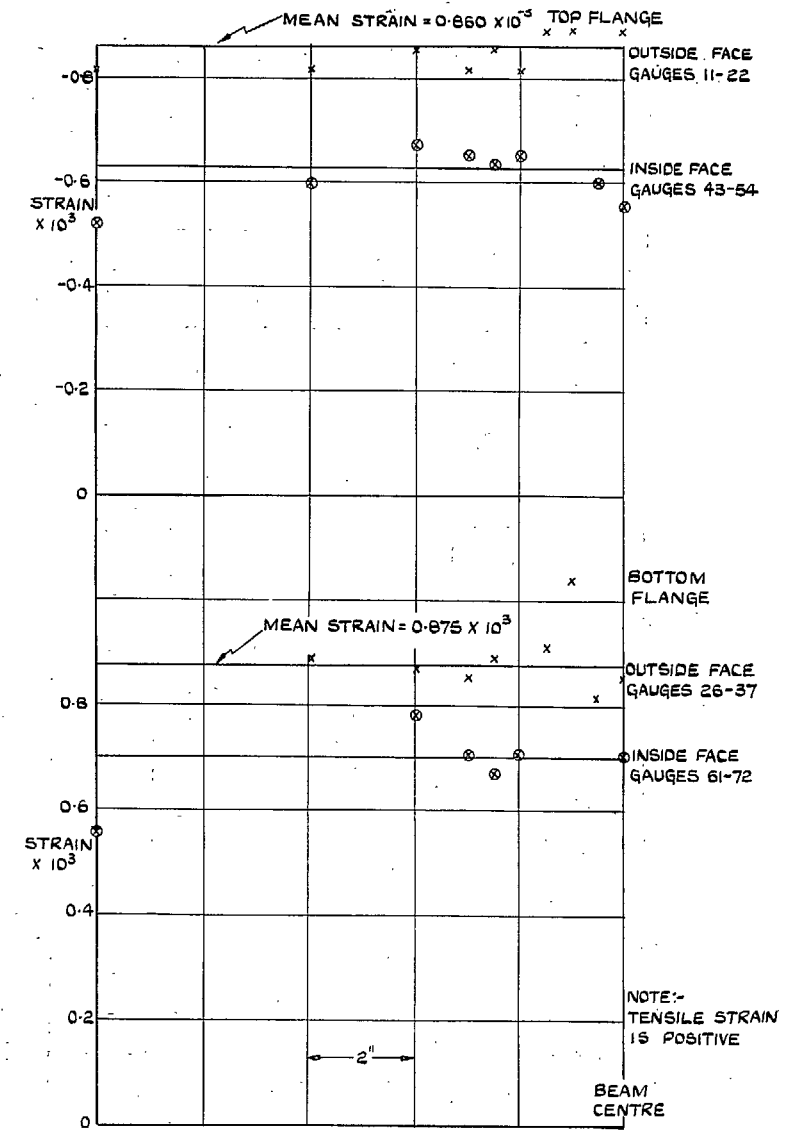

FIG. 10. Strain-gauge results in pure bending test. Readings with 800 lb at C and D (i.e., bending moment of 9,600 lb/in. between C and D).

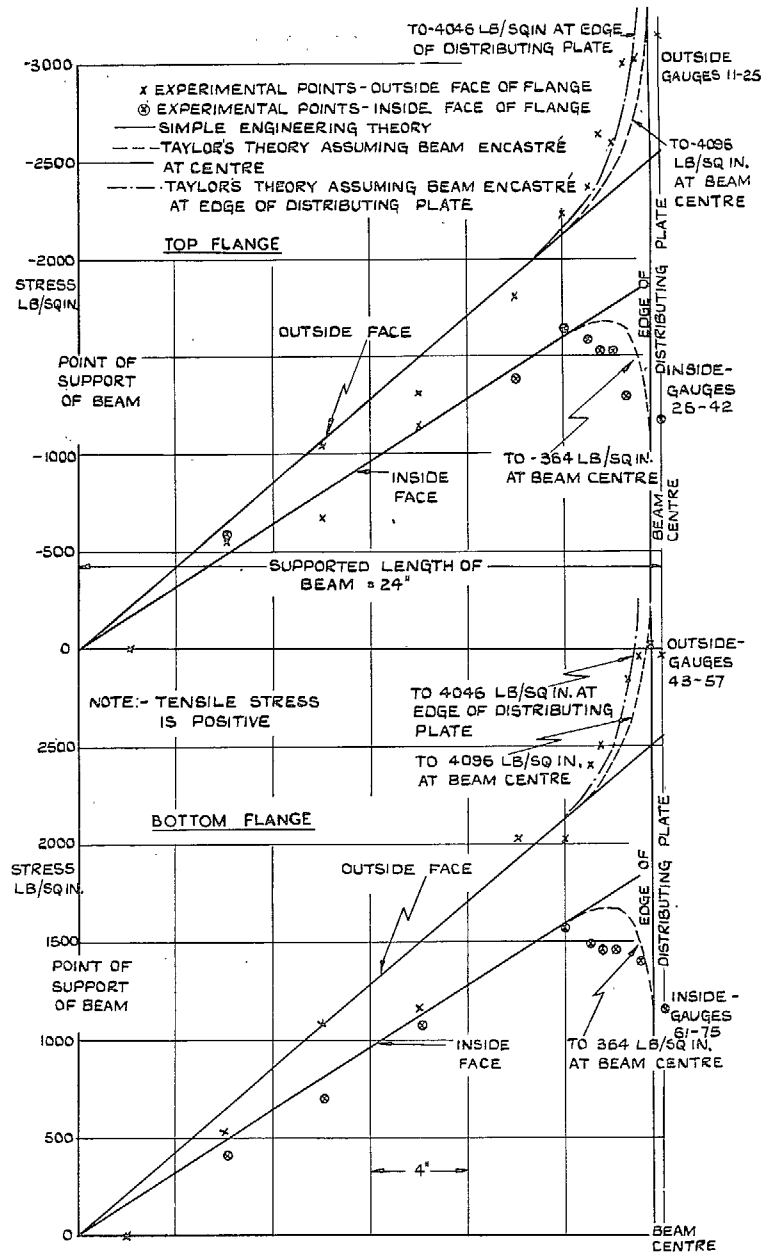

FIG. 11. Strain-gauge results and theoretical stress distributions in 3-point loading test (supports at C and D). Readings with a centre load of 1,920 lb.

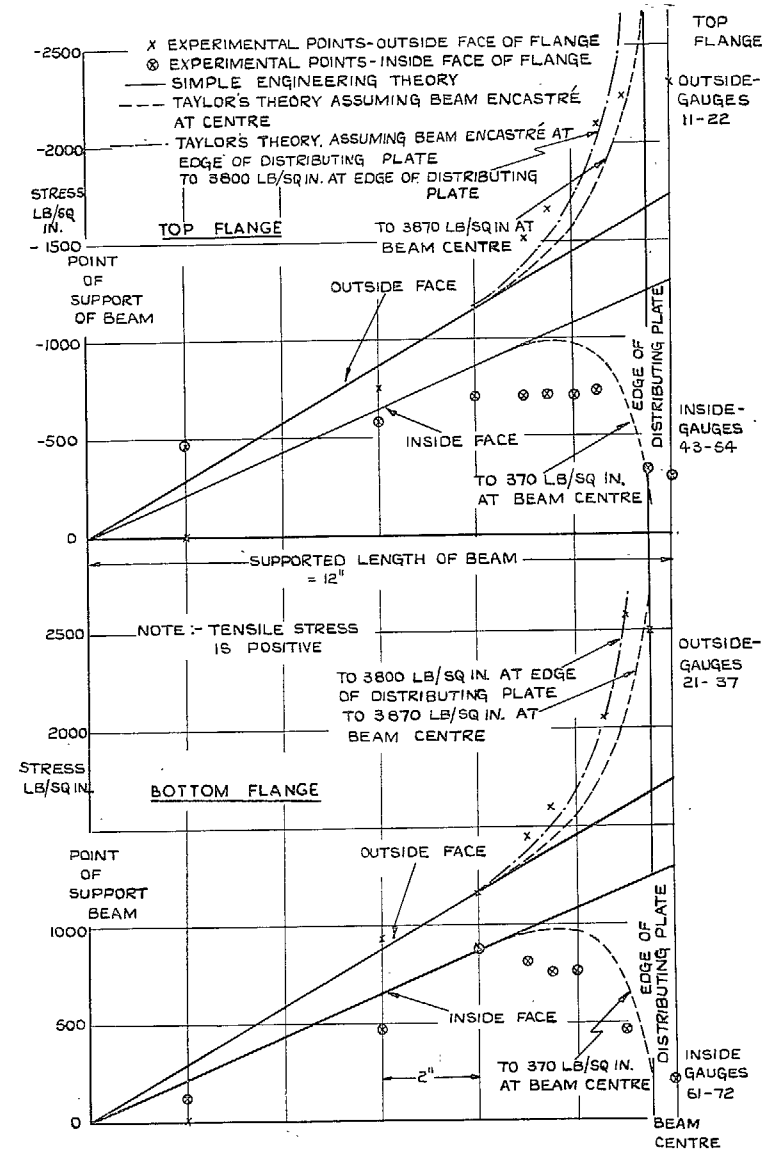

FIG. 12. Strain-gauge results and theoretical stress distributions in 3-point loading test (supports at A and B). Readings with a centre load of 1,400 lb.

## Publications of the Aeronautical Research Council

### ANNUAL TECHNICAL REPORTS OF THE AERONAUTICAL RESEARCH COUNCIL (BOUND VOLUMES)

- 1936 Vol. I. Aerodynamics General, Performance, Airscrews, Flutter and Spinning. 40s. (40s. 9d.)  
Vol. II. Stability and Control, Structures, Seaplanes, Engines, etc. 50s. (50s. 10d.)
- 1937 Vol. I. Aerodynamics General, Performance, Airscrews, Flutter and Spinning. 40s. (40s. 10d.)  
Vol. II. Stability and Control, Structures, Seaplanes, Engines, etc. 60s. (61s.)
- 1938 Vol. I. Aerodynamics General, Performance, Airscrews. 50s. (51s.)  
Vol. II. Stability and Control, Flutter, Structures, Seaplanes, Wind Tunnels, Materials. 30s. (30s. 9d.)
- 1939 Vol. I. Aerodynamics General, Performance, Airscrews, Engines. 50s. (50s. 11d.)  
Vol. II. Stability and Control, Flutter and Vibration, Instruments, Structures, Seaplanes, etc. 63s. (64s. 2d.)
- 1940 Aero and Hydrodynamics, Aerofoils, Airscrews, Engines, Flutter, Icing, Stability and Control, Structures, and a miscellaneous section. 50s. (51s.)
- 1941 Aero and Hydrodynamics, Aerofoils, Airscrews, Engines, Flutter, Stability and Control, Structures. 63s. (64s. 2d.)
- 1942 Vol. I. Aero and Hydrodynamics, Aerofoils, Airscrews, Engines. 75s. (76s. 3d.)  
Vol. II. Noise, Parachutes, Stability and Control, Structures, Vibration, Wind Tunnels. 47s. 6d. (48s. 5d.)
- 1943 Vol. I. (*In the press.*)  
Vol. II. (*In the press.*)

### ANNUAL REPORTS OF THE AERONAUTICAL RESEARCH COUNCIL—

1933-34	1s. 6d. (1s. 8d.)	1937	2s. (2s. 2d.)
1934-35	1s. 6d. (1s. 8d.)	1938	1s. 6d. (1s. 8d.)
April 1, 1935 to Dec. 31, 1936.	4s. (4s. 4d.)	1939-48	3s. (3s. 2d.)

### INDEX TO ALL REPORTS AND MEMORANDA PUBLISHED IN THE ANNUAL TECHNICAL REPORTS, AND SEPARATELY—

April, 1950 - - - - R. & M. No. 2600. 2s. 6d. (2s. 7½d.)

### AUTHOR INDEX TO ALL REPORTS AND MEMORANDA OF THE AERONAUTICAL RESEARCH COUNCIL—

1909-1949. R. & M. No. 2570. 15s. (15s. 3d.)

### INDEXES TO THE TECHNICAL REPORTS OF THE AERONAUTICAL RESEARCH COUNCIL—

December 1, 1936 — June 30, 1939.	R. & M. No. 1850.	1s. 3d. (1s. 4½d.)
July 1, 1939 — June 30, 1945.	R. & M. No. 1950.	1s. (1s. 1½d.)
July 1, 1945 — June 30, 1946.	R. & M. No. 2050.	1s. (1s. 1½d.)
July 1, 1946 — December 31, 1946.	R. & M. No. 2150.	1s. 3d. (1s. 4½d.)
January 1, 1947 — June 30, 1947.	R. & M. No. 2250.	1s. 3d. (1s. 4½d.)
July, 1951.	R. & M. No. 2350.	1s. 9d. (1s. 10½d.)

*Prices in brackets include postage.*

Obtainable from

### HER MAJESTY'S STATIONERY OFFICE

York House, Kingsway, London, W.C.2; 423 Oxford Street, London, W.1 (Post Orders:  
P.O. Box 569, London, S.E.1); 13a Castle Street, Edinburgh 2; 39, King Street, Manchester, 2;  
2 Edmund Street, Birmingham 3; 1 St. Andrew's Crescent, Cardiff; Tower Lane, Bristol 1;  
80 Chichester Street, Belfast, or through any bookseller