



NATIONAL AERONAUTICAL
ESTABLISHMENT
LIBRARY
MAY 1953
LONDON

RECEIVED
AERONAUTICAL RESEARCH COUNCIL
MAY 1953

MINISTRY OF SUPPLY

AERONAUTICAL RESEARCH COUNCIL
REPORTS AND MEMORANDA

A Method of Performance Reduction for Helicopters

By

F. O'HARA, M.A.

Crown Copyright Reserved

LONDON: HER MAJESTY'S STATIONERY OFFICE

1952

PRICE 3s 6d NET

A Method of Performance Reduction for Helicopters

By

F. O'HARA, M.A.

COMMUNICATED BY THE PRINCIPAL DIRECTOR OF SCIENTIFIC RESEARCH (AIR),
MINISTRY OF SUPPLY

*Reports and Memoranda No. 2770**

October, 1947

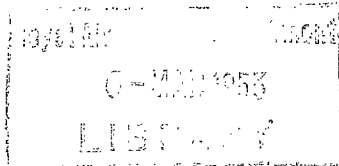

Summary.—The equations for helicopter performance are derived in a form suitable for the development of performance reduction methods, and the equations obtained provide also a simple method of performance estimation. Formulæ are determined for reducing observed performance data to standard temperature conditions and for estimating the effect of weight changes on performance. Charts of the relationships are given for typical values of helicopter and engine characteristics.

The general equations are divided into two groups dealing respectively with forward and vertical flight. Performance reduction methods are then outlined for the three cases of climbing, level and vertical flight and are applied to show the effect of weight changes in each case.

1. *Introduction.*—Existing methods of helicopter performance estimation do not appear to be directly applicable to the reduction of measured performance data, because quantities not normally observed occur in the final performance equations. In this report, the performance equations are derived in a modified form suitable for the development of reduction formulæ; the form obtained provides a simple method of performance estimation. The treatment is for a helicopter with a single main rotor and some torque-compensating device such as an auxiliary rotor. The assumptions about the helicopter are the same as those made by Squire in R. & M. 1730¹ and the approach is similar to that of Wald² but the final performance equations have been obtained in a form not containing the disc incidence.

2. *Velocity Equations.*—The helicopter is assumed to be flying with velocity V and the angle of incidence of the rotor disc is i . The induced velocity v is assumed constant over the disc and is directed perpendicular to it. The velocity in the plane of the disc is $V \cos i$ and the velocity perpendicular to it is $u = v + V \sin i$. The resultant of the components V' is given by the equation:—

$$V'^2 = v^2 + V^2 + 2vV \sin i. \quad \dots \dots \dots (1)$$

The rotor thrust is assumed (R. & M. 1730¹) to be

$$L = 2\pi\rho e^2 R^2 V' v$$

where eR is the effective rotor radius with allowance made for tip losses^{2,3}.

For the purposes of performance reduction it is convenient to work in terms of equivalent air speeds, which are denoted by the suffix i . Thus if ρ_0 is the air density at sea level

$$L = 2\pi\rho_0 e^2 R^2 V'_i v_i$$

For all practical aspects of steady flight it may be assumed that the rotor thrust equals the aircraft weight W . Introducing v_0 such that $2\pi\rho_0 e^2 R^2 v_0^2 = W$, then

$$V'_i v_i = v_0^2 \quad \dots \dots \dots (2)$$

*A.F.E.E. Report Res. 26—received 2nd December, 1947.

The later analysis is developed in terms of V_i/v_0 and v_i/v_0 , which are written x and y respectively. From (1) and (2) the relation of the disc incidence to the velocity terms is given by

$$x \sin i = \frac{1}{2} \left(\frac{1}{y^3} - y - \frac{x^2}{y} \right) \quad \dots \quad \dots \quad \dots \quad \dots \quad \dots \quad \dots \quad \dots \quad \dots \quad \dots \quad (3)$$

2.1. *Performance Equations.*—The performance of the helicopter may be determined from the rotor power equation and the energy equation. The rotor power equation is derived by equating the rate of work done by the thrust to the effective power at the rotor less that expended in rotating the blades². If P is the total engine power and EP the effective power when allowance is made for transmission losses, power to tail rotor, etc.,

$$EP - P_R = W_u$$

$$\text{where } P_R = \frac{\rho}{8} C_D b c R \Omega^3 R^3 (1 + \mu^2)$$

The tip speed ratio $\mu = x \cos i/w$, where $w = \Omega_i R/v_0$.

Using (3), the power equation may be written in a form used later in performance reduction

$$\frac{EP\sqrt{\sigma}}{\pi\rho_0 e^2 R^2 v_0^3} = \left[\frac{1}{y^3} + y - \frac{x^2}{y} \right] + r_c \left[w^2 + \left\{ x^2 - \frac{1}{4} \left(\frac{1}{y^3} - y - \frac{x^2}{y} \right)^2 \right\} \right] \quad \dots \quad \dots \quad (4)$$

$$\text{where } r_c = C_D s' w / 8e^2.$$

With the torque coefficient $q_c = P/(bcR\rho\Omega^3R^3)$, and putting $p = (8Eq_c/C_D - 1)$, this equation becomes

$$w^2 p = \frac{1}{r_c} \left\{ \frac{1}{y^3} + y - \frac{x^2}{y} \right\} + \left[x^2 - \frac{1}{4} \left(\frac{1}{y^3} - y - \frac{x^2}{y} \right)^2 \right]. \quad \dots \quad \dots \quad \dots \quad \dots \quad (5)$$

The energy equation from R. & M. 1730¹, is

$$EP = V_c W + vW + \frac{\rho}{8} C_D b c R \Omega^3 R^3 (1 + 3\mu^2) + \frac{V_i^{3'} D}{\sqrt{\sigma} 100^3}$$

where D is the body drag at 100 f.p.s.

Combination of the power and energy equations leads to

$$z + \frac{d_c}{y^3} = \frac{1}{2} \left(\frac{1}{y^3} - y - \frac{x^2}{y} \right) - r_c \left\{ x^2 - \frac{1}{4} \left(\frac{1}{y^3} - y - \frac{x^2}{y} \right)^2 \right\} \quad \dots \quad \dots \quad \dots \quad (6)$$

$$\text{where } z = V_c \sqrt{\sigma}/v_0 \text{ and } d_c = D/(2\pi\rho_0 e^2 R^2 100^3).$$

Equations (5) and (6) are in a form convenient for general performance analysis. Knowing the fixed constants of the helicopter, y is determined by (5) for chosen values of q_c , x , w and σ . The corresponding value of z (and therefore of V_c) follows from (6). Performance estimates can be made from charts of these equations in the forms given in Figs. 1 and 2. The main lines of the chart in Fig. 1 are based on a typical value of r_c , but the effect of alteration in r_c is indicated by subsidiary lines. Similarly in Fig. 2 the effect of alteration in d_c is indicated by subsidiary lines.

The mean blade angle θ_0 and the amplitude of variation θ_1 can also be determined, using equations (11) and (14) of R. & M. 1730¹. When y is determined it is possible from (3) of this report to find $\mu = x \cos i/w$ and $\lambda = (y + x \sin i)/w$; then from R. & M. 1730¹,

$$\theta_0 = \frac{3}{2} \left[\frac{C_D}{a r_c w} + \frac{1 - \frac{1}{2}\mu^2}{1 + \frac{3}{2}\mu^2} \lambda \right] \frac{1 + \frac{3}{2}\mu^2}{1 - \mu^2 + \frac{9}{4}\mu^4}$$

$$\theta_1 = \frac{8}{3}\mu \frac{\theta_0 - \frac{3}{4}\lambda}{1 + \frac{3}{2}\mu^2}.$$

2.1.1. *Level flight*.—From the energy equation in level flight (equation (6) with $z = 0$)

$$x^2 = \frac{1}{y^2} + y^2 - \frac{y}{r_c} \left[\left(1 + 4r_c y + \frac{4r_c^2}{y^2} + 4r_c \frac{d_c}{y^3} \right)^{1/2} - 1 \right] \quad \dots \quad \dots \quad \dots \quad \dots \quad (7)$$

The sign of the root term depends on that of $(1/y^3 - y - x^2/y)$, which from (3) is $2x \sin i$. This is positive in normal level flight.

The power equation (5) applies also to the level flight. It is possible to eliminate y numerically from (5) and (7) and obtain a relationship between x , $w^2 p$, r_c and d_c . This is plotted in lattice form in Fig. 3 from which it is possible to find the level speed for given power and drag characteristics.

2.1.2. *Vertical flight*.—In vertical flight, neglecting the drag of the fuselage, equation (2) leads to

$$z = \frac{1}{y} - y. \quad \dots \quad \dots \quad \dots \quad \dots \quad \dots \quad \dots \quad \dots \quad \dots \quad \dots \quad (8)$$

The energy equation may be written

$$z = \frac{1}{2} r_c w^2 p - y.$$

Hence using (8)

$$z = \frac{1}{2} r_c w^2 p - \frac{2}{r_c w^2 p}. \quad \dots \quad \dots \quad \dots \quad \dots \quad \dots \quad \dots \quad \dots \quad (9)$$

This is the formula for estimating vertical performance in terms of the helicopter constants. The above analysis only applies where the assumed form for the thrust equation is valid; it does not obtain for the rotor operating in the vortex ring condition, that is in rapid power-on descent.

3. *Performance Reduction Methods*.—Current methods of performance reduction for fixed wing aircraft are derived from the performance equation assuming laws of variation of engine power and propeller efficiency based on experimental data. Corrections to observed performance data are usually made at constant propeller speed and, in the case of climb, at constant airspeed. Helicopter reduction methods are obtained similarly from the performance equations assuming a law of power variation and that the rotor thrust equals the aircraft weight.

The performance of a helicopter is determined by the power and energy equations (5) and (6). The induced velocity term y may be eliminated and the parameters of performance are q_c , w , x , and z . These may be used to develop a height change method of performance reduction; the law of power variation determines the height in the standard atmosphere at which the measured performance specified by w , x , z applies. The disadvantage of this method is that a change in the true rotor speed is involved whereas in practice rotor (or engine) speed is one of the fixed flight conditions. A correction for the change in rotor speed could be used but, because the height range covered by the performance is at present often very limited, reduction methods are developed here for constant pressure height and constant rotor speed.

3.1. *Climbing Flight*.—The method of analysis used for climb reduction involves finding the effect of temperature on y . The value of y in observed conditions may be found from (6) or Fig. 2, at known x and z . The variation of y with temperature is found from (4); part of the final term

in this equation is small (of $0(\mu^2)$) in normal climbing conditions and may be neglected. Assuming the power law $P \propto T^K$ then, taking $\delta T = T - T_s$ (since conventionally $\delta T > 0$ on a day hotter than standard),

$$y_s = y \left(1 + \frac{\delta v_i}{v_i} \delta T \right)$$

where

$$\frac{\delta v_i}{v_i} = \frac{(K - 0.5) \left\{ \frac{1}{y^3} + y - \frac{x^2}{y} \right\} + (K + 1) r_c \omega^2}{T \left\{ \frac{3}{y^3} - y - \frac{x^2}{y} \right\}} \quad \dots \quad \dots \quad \dots \quad (10)$$

$\delta v_i/v_i$ is charted for $K = -0.75$ and mean values of T and $r_c \omega^2$ in Fig. 4.

The value of z_s may now be determined from Fig. 2 and the rate of climb in standard I.C.A.N. conditions, V_c^s , is $v_0 z_s / \sqrt{\sigma_s}$.

Alternatively the increment to the rate of climb may be obtained from (6); for reduction to standard I.C.A.N. conditions,

$$V_c^s = V_c^a \left(1 + \frac{\delta T}{2T} \right) + H v_0 \delta T$$

where

$$H = - \frac{1}{2\sqrt{\sigma_s}} \left\{ \frac{3}{y^3} + y - \frac{x^2}{y} - \frac{6d_c}{y^3} \right\} \frac{\delta v_i}{v_i} \quad \dots \quad \dots \quad \dots \quad (11)$$

H is charted for $K = -0.75$ in Fig. 5.

3.2. Level Flight.—The relationship between x and y for level flight (7) makes it possible to find the variation of x with temperature from the rotor power equation alone. It may be shown from (5), with $t = T/T_s$, that

$$Y = \left[\left\{ \frac{1}{y^3} + y - \frac{x^2}{y} \right\} t^{0.5-K} + \frac{r_s \omega_s^2}{t^{1+K}} + \frac{r_s}{t^K} \left\{ x^2 - \frac{1}{4} \left(\frac{1}{y^3} - y - \frac{x^2}{y} \right)^2 \right\} \right] \quad \dots \quad \dots \quad (12)$$

is invariant with t .

Y is charted in Fig. 6 as a function of x and t using the x, y relation from (7). This chart provides a method of level speed reduction; since the value of Y corresponding to given speed and temperature conditions remains constant when the temperature is changed the speed appropriate to the changed conditions may be determined.

It is also possible to obtain a correction in the form of an increment to the speed but this method is evidently inaccurate for speeds in the neighbourhood of $dY/dx = 0$.

3.3. Vertical Flight.—It follows from (9) that

$$J = \left[\frac{V_c^a \sqrt{\sigma_s}}{v_0} t^{1-K} + t^{0.5-K} \left\{ 4 + \left(\frac{V_c^a \sqrt{\sigma_s}}{v_0} \right)^2 t \right\}^{1/2} + \frac{r_s \omega_s^2}{t^{1+K}} \right] \quad \dots \quad \dots \quad (13)$$

is invariant with t .

J is plotted in Fig. 7 in a form providing a method of vertical climb reduction similar to that for level flight.

4. Effect of Weight Changes.—The only quantities in the performance equations (5) and (6) which vary with weight are v_0 and r_c . It is convenient in some of the analysis to replace r_c by v_r/v_0 where v_r is independent of W . The effect of changes in weight can then be studied through variations in v_0 alone.

LIST OF SYMBOLS

- a* slope of blade lift curve
A reduction constant defined by (14)
b number of blades
c rotor blade chord at $r = 0.7R$
 C_D blade profile drag coefficient at the mean effective lift coefficient
 $d_c = \frac{D}{2\pi\rho_0 e^2 R^2 \cdot 100^2}$
D fuselage drag at 100 f.p.s.
e tip loss factor
E ratio of effective power at rotor to total power
H reduction constant defined by (11)
i rotor disc incidence to the wind direction
J reduction constant defined by (13)
K index of variation of power with temperature
L rotor thrust
M reduction constant defined by (15)
N reduction constant defined by (16)
 $\phi = \frac{8Eq_c}{C_D} - 1$
P engine power
 P_R power required for rotor torque due to profile drag
 $q_c = \frac{P}{bcR\rho\Omega^3 R^3}$
 $r_c = \frac{C_D s \Omega_i R}{8e^2 v_0}$
 $r_s = \frac{C_D s \Omega_{is} R}{8e^2 v_0}$
R rotor radius
 $s = \frac{bc}{\pi R}$, rotor solidity ratio
 $t = \frac{T}{T_s}$
T air temperature
 T_s standard I.C.A.N. air temperature
u total flow normal to rotor disc
 $u_i = u\sqrt{\sigma}$
v induced velocity

$$v_i = v\sqrt{\sigma}$$

$$v_0 = \left(\frac{W}{2\pi\rho_0 e^2 R^2} \right)^{1/2}$$

$$v_r = v_0 r_c$$

V aircraft speed

V_c rate of climb

V_c^a altimeter rate of climb

V_c^s rate of climb in standard I.C.A.N. conditions

$$V_i = V\sqrt{\sigma}$$

V' resultant air velocity at the rotor

$$V'_i = V'\sqrt{\sigma}$$

$$w = \frac{\Omega_i R}{v_0}$$

$$w_s = \frac{\Omega_{is} R}{v_0}$$

W aircraft weight

$$x = \frac{V_i}{v_0}$$

$$y = \frac{v_i}{v_0}$$

Y reduction constant defined by (12)

$$z = \frac{V_c \sqrt{\sigma}}{v_0}$$

z_s value of z in standard conditions

θ_0 mean blade angle

θ_1 amplitude of blade angle variation

$$\mu = \frac{V_i \cos i}{\Omega_i R}$$

$$\lambda = \frac{v_i + V_i \sin i}{\Omega_i R}$$

Ω rotor angular velocity

$$\Omega_i = \Omega\sqrt{\sigma}$$

$$\Omega_{is} = \Omega\sqrt{\sigma_s}$$

ρ air density

ρ_0 air density at sea level

σ relative air density

σ_s relative air density in standard conditions

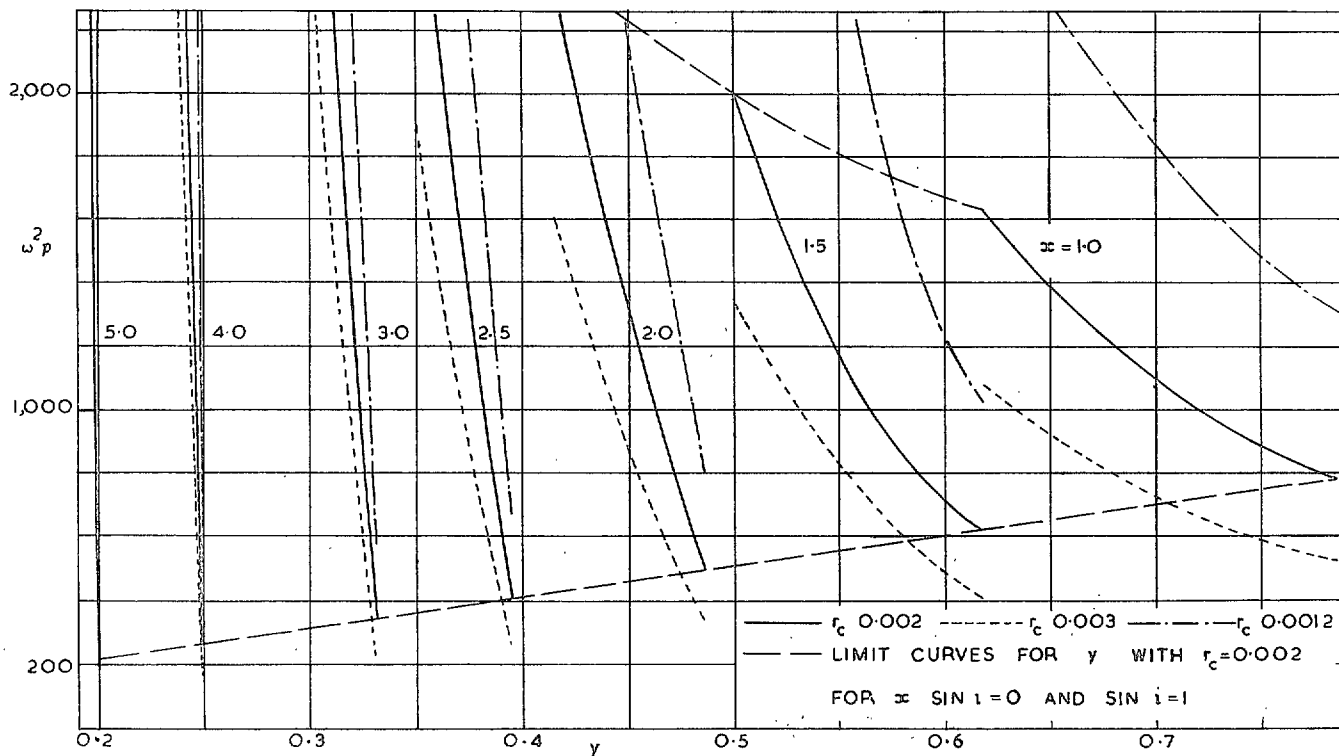

FIG. 1. Chart of rotor power equation.

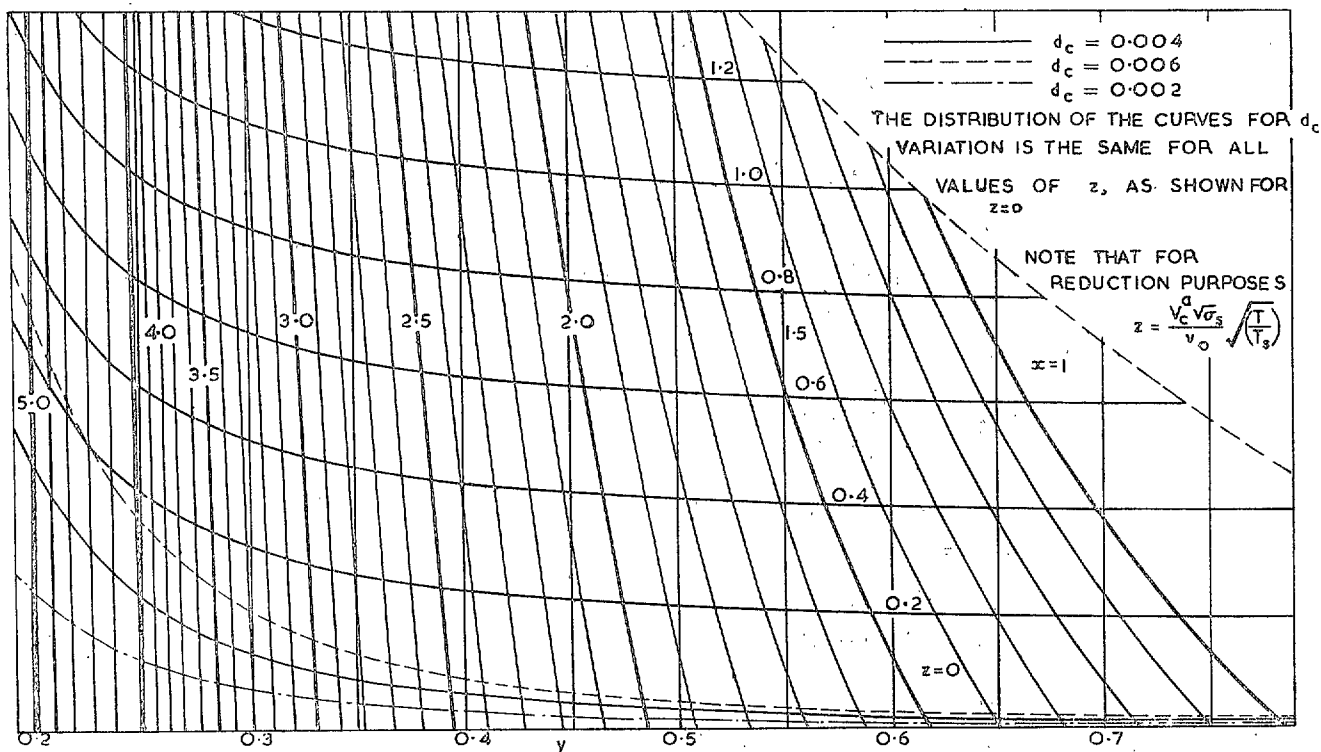

FIG. 2. Chart of energy equation.

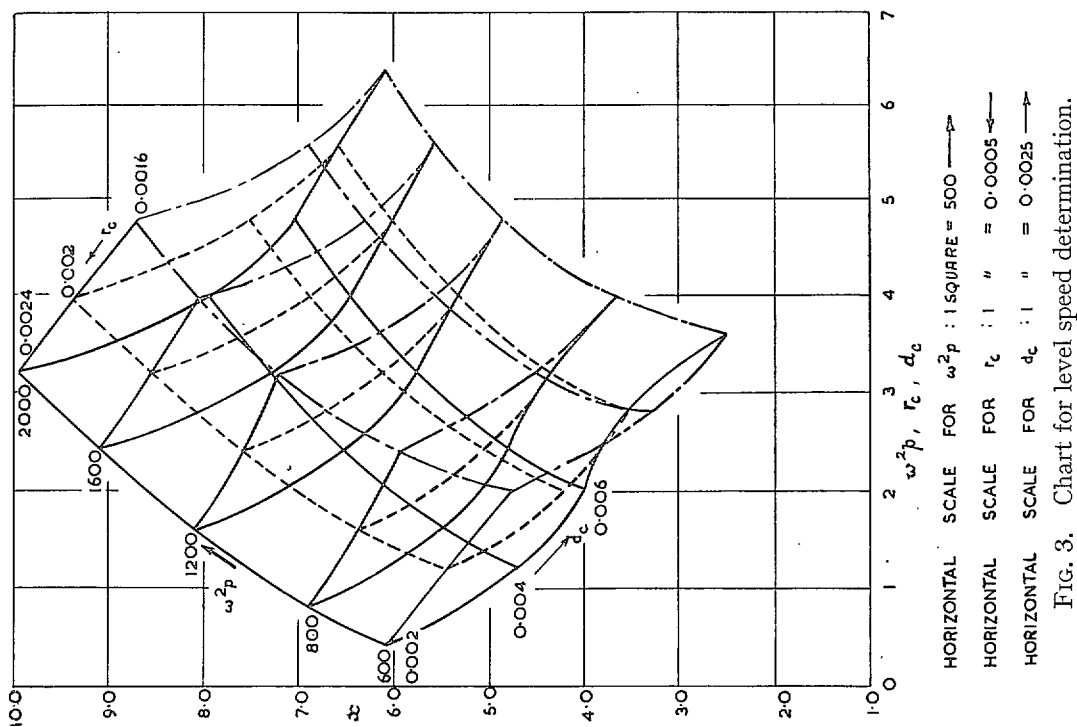

FIG. 3. Chart for level speed determination.

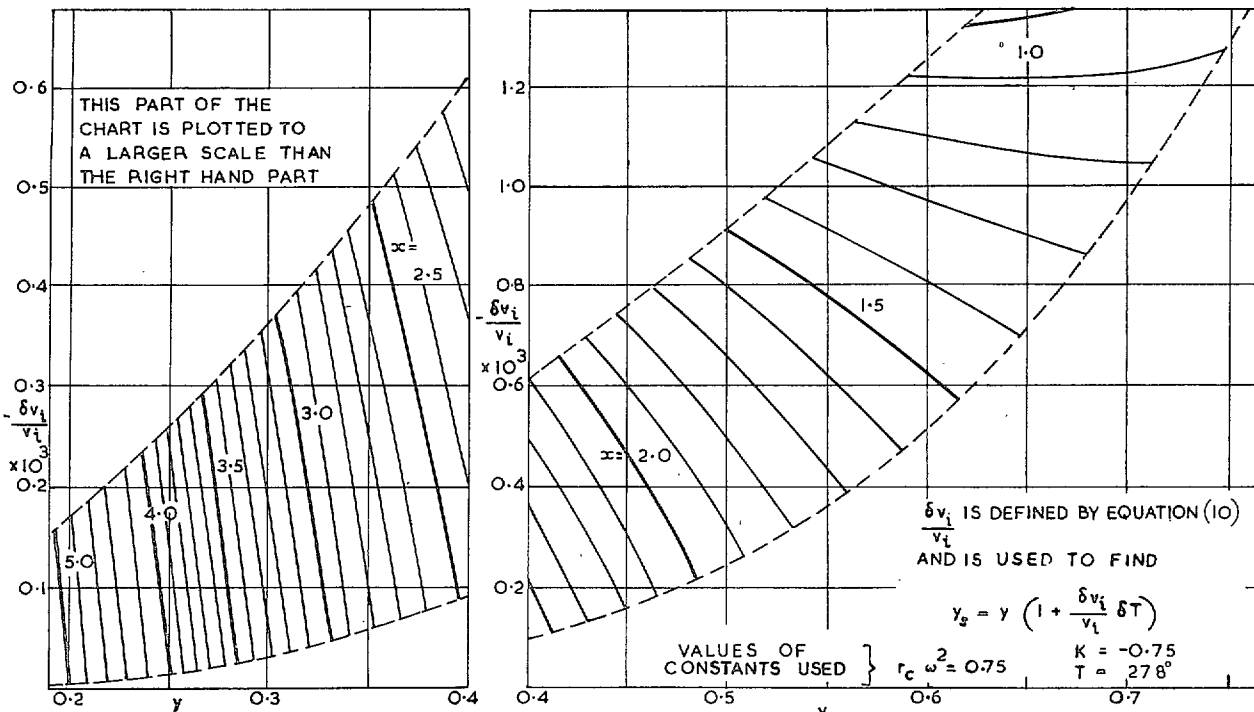

FIG. 4. Chart of $\delta v_i/v_i$.

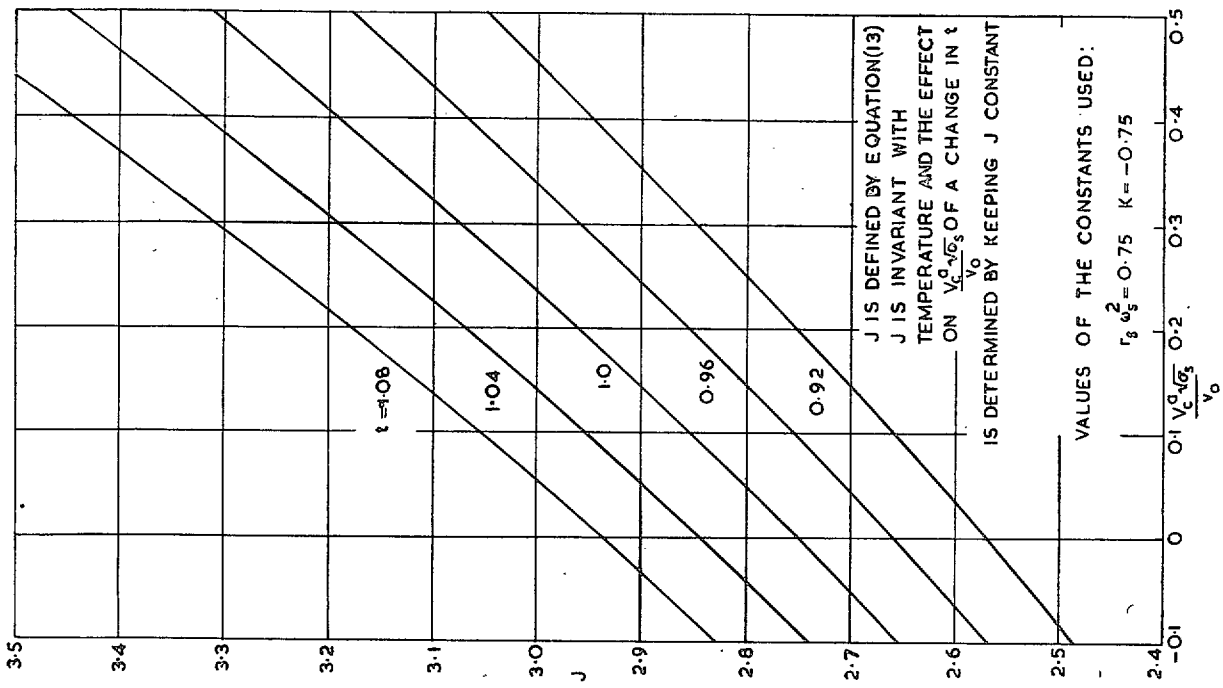

Fig. 7. Chart for vertical climb reduction.

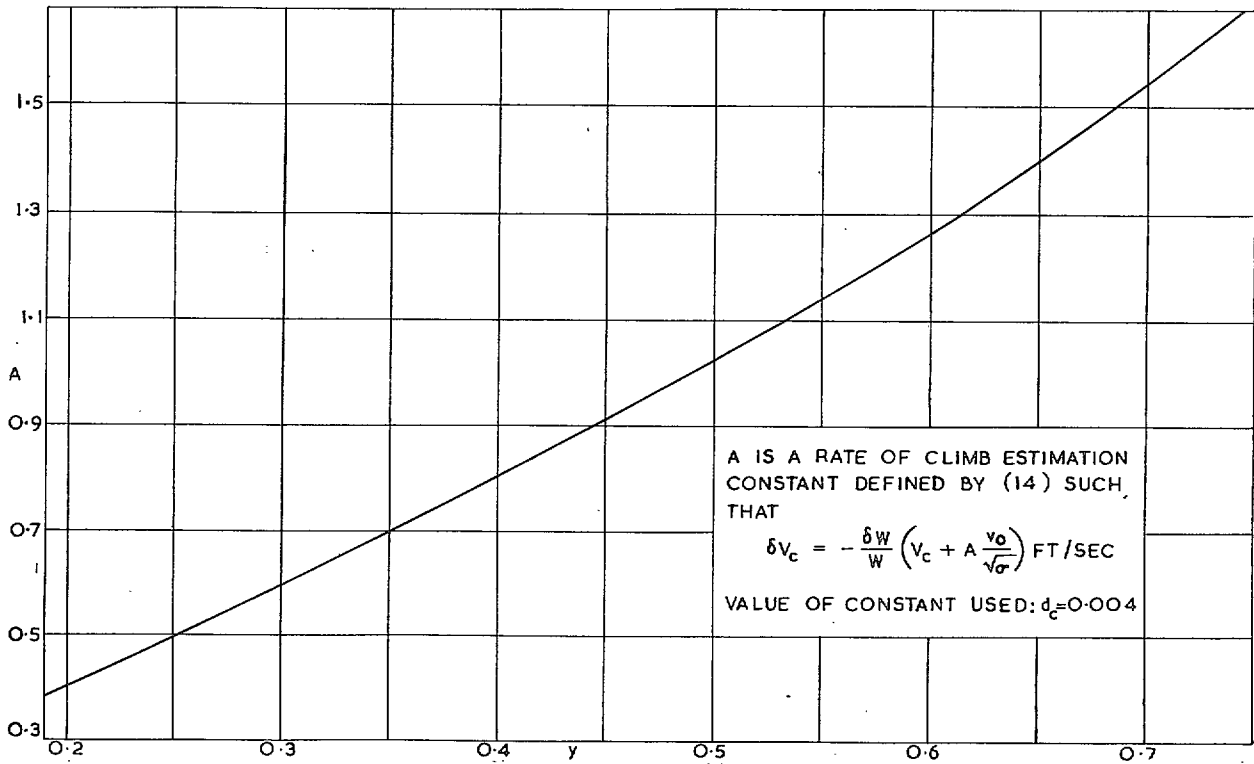

Fig. 8. Chart for determining effect of weight changes on rate of climb.

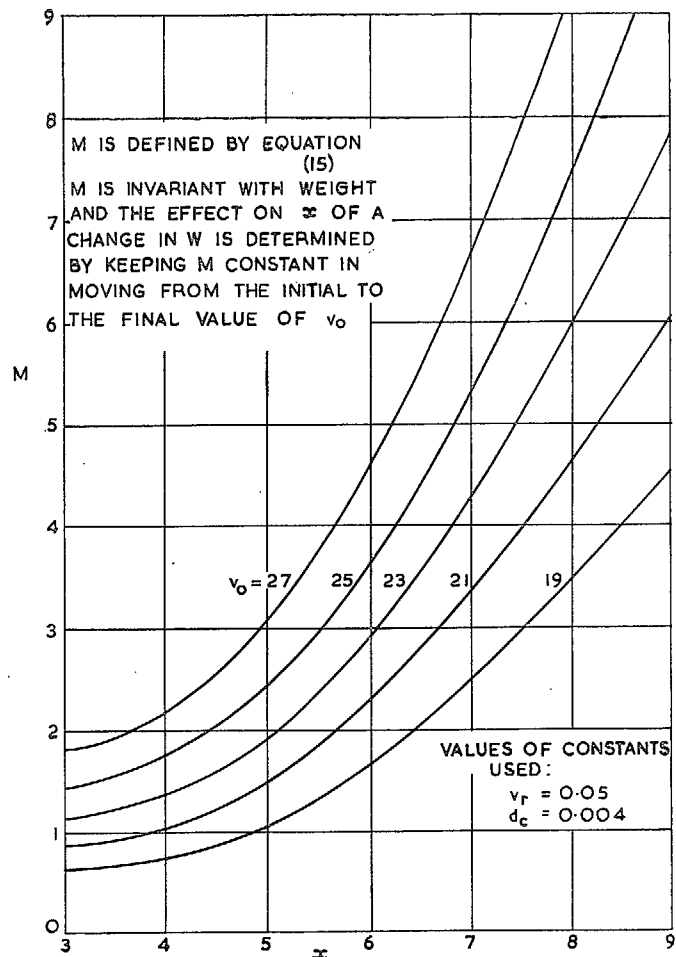

FIG. 9. Chart for determining effect of weight changes on level speed.

N IS DEFINED BY EQUATION (16)
 N IS INVARIANT WITH WEIGHT AND THE EFFECT ON $v_c \sqrt{\sigma}$ OF A CHANGE IN W IS DETERMINED BY KEEPING N CONSTANT IN MOVING FROM THE INITIAL TO THE FINAL VALUE OF v_0

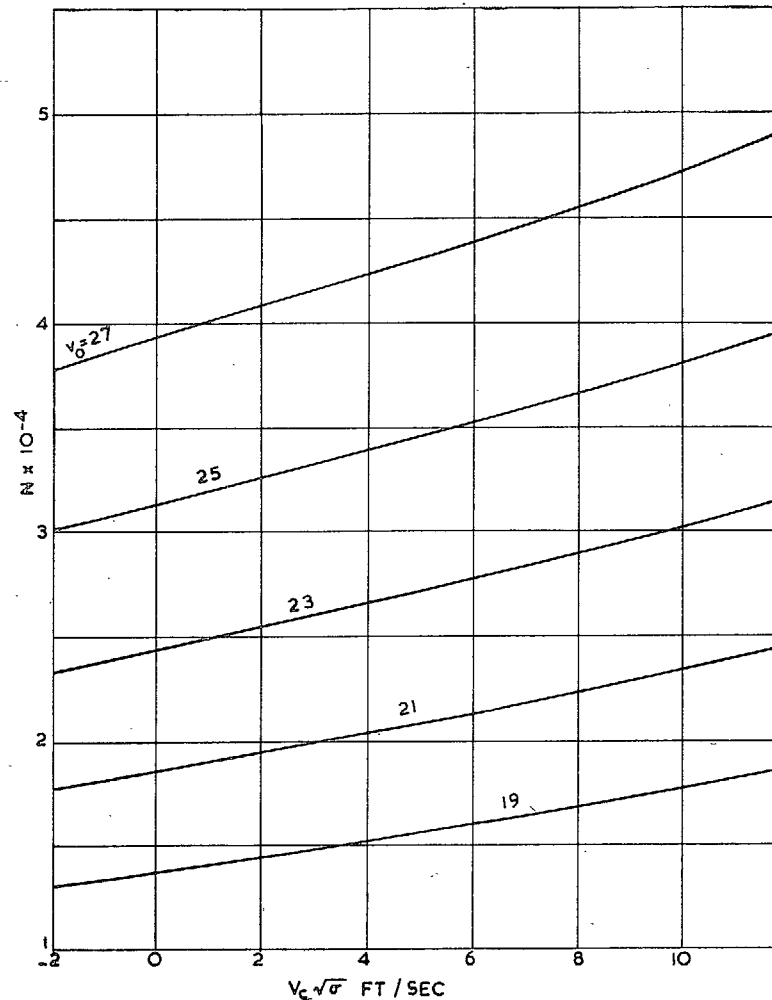

FIG. 10. Chart for determining effect of weight changes on vertical rate of climb.

Publications of the Aeronautical Research Council

ANNUAL TECHNICAL REPORTS OF THE AERONAUTICAL RESEARCH COUNCIL (BOUND VOLUMES)—

- 1934-35 Vol. I. Aerodynamics. *Out of print.*
Vol. II. Seaplanes, Structures, Engines, Materials, etc. 40s. (40s. 8d.)
- 1935-36 Vol. I. Aerodynamics. 30s. (30s. 7d.)
Vol. II. Structures, Flutter, Engines, Seaplanes, etc. 30s. (30s. 7d.)
- 1936 Vol. I. Aerodynamics General, Performance, Airscrews, Flutter and Spinning. 40s. (40s. 9d.)
Vol. II. Stability and Control, Structures, Seaplanes, Engines, etc. 50s. (50s. 10d.)
- 1937 Vol. I. Aerodynamics General, Performance, Airscrews, Flutter and Spinning. 40s. (40s. 10d.)
Vol. II. Stability and Control, Structures, Seaplanes, Engines, etc. 60s. (61s.)
- 1938 Vol. I. Aerodynamics General, Performance, Airscrews. 50s. (51s.)
Vol. II. Stability and Control, Flutter, Structures, Seaplanes, Wind Tunnels, Materials. 30s. (30s. 9d.)
- 1939 Vol. I. Aerodynamics General, Performance, Airscrews, Engines. 50s. (50s. 11d.)
Vol. II. Stability and Control, Flutter and Vibration, Instruments, Structures, Seaplanes, etc. 63s. (64s. 2d.)
- 1940 Aero and Hydrodynamics, Aerofoils, Airscrews, Engines, Flutter, Icing, Stability and Control, Structures, and a miscellaneous section. 50s. (51s.)

Certain other reports proper to the 1940 volume will subsequently be included in a separate volume.

ANNUAL REPORTS OF THE AERONAUTICAL RESEARCH COUNCIL—

| | |
|-------------------------------------|-------------------|
| 1933-34 | 1s. 6d. (1s. 8d.) |
| 1934-35 | 1s. 6d. (1s. 8d.) |
| April 1, 1935 to December 31, 1936. | 4s. (4s. 4d.) |
| 1937 | 2s. (2s. 2d.) |
| 1938 | 1s. 6d. (1s. 8d.) |
| 1939-48 | 3s. (3s. 2d.) |

INDEX TO ALL REPORTS AND MEMORANDA PUBLISHED IN THE ANNUAL TECHNICAL REPORTS, AND SEPARATELY—

April, 1950 R. & M. No. 2600. 2s. 6d. (2s. 7½d.)

INDEXES TO THE TECHNICAL REPORTS OF THE AERONAUTICAL RESEARCH COUNCIL—

| | | |
|------------------------------------|-------------------|--------------------|
| December 1, 1936 — June 30, 1939. | R. & M. No. 1850. | 1s. 3d. (1s. 4½d.) |
| July 1, 1939 — June 30, 1945. | R. & M. No. 1950. | 1s. (1s. 1½d.) |
| July 1, 1945 — June 30, 1946. | R. & M. No. 2050. | 1s. (1s. 1½d.) |
| July 1, 1946. — December 31, 1946. | R. & M. No. 2150. | 1s. 3d. (1s. 4½d.) |
| January 1, 1947 — June 30, 1947. | R. & M. No. 2250. | 1s. 3d. (1s. 4½d.) |

Prices in brackets include postage.

Obtainable from

HER MAJESTY'S STATIONERY OFFICE

York House, Kingsway, LONDON, W.C.2 423 Oxford Street, LONDON, W.1
P.O. Box 569, LONDON, S.E.1

13a Castle Street, EDINBURGH, 2 1 St. Andrew's Crescent, CARDIFF
39 King Street, MANCHESTER, 2 Tower Lane, BRISTOL 1
2 Edmund Street, BIRMINGHAM, 3 80 Chichester Street, BELFAST

or through any bookseller.