



PROCUREMENT EXECUTIVE, MINISTRY OF DEFENCE

AERONAUTICAL RESEARCH COUNCIL

CURRENT PAPERS

A Comparison of Fatigue Crack Propagation Rates
in CM002 (Unclad RR58) Aluminium Alloy
immersed in Jet Fuel and a Fuel Simulant

by

F. E. Keates and R. F. Mousley

Structures Dept., R.A.E., Farnborough

RECEIVED
1977
R.A.E.

LONDON: HER MAJESTY'S STATIONERY OFFICE

1977

£1.50 NET

*CP No.1365

April 1976

A COMPARISON OF FATIGUE CRACK PROPAGATION RATES IN CM002 (UNCLAD RR58)
ALUMINIUM ALLOY IMMERSSED IN JET FUEL AND A FUEL SIMULANT

by

F. E. Keates

R. F. Mousley

SUMMARY

Fatigue crack propagation tests were conducted on CM002 (unclad RR58) aluminium alloy sheet under a flight-by-flight loading sequence. The specimens were immersed in jet fuel at 70°C and in fuel simulant at 90°C to simulate conditions in Concorde service and in the Concorde Major Fatigue Test respectively. No large difference in crack propagation was observed. Comparison with the results of similar tests in air at room temperature and at 90°C suggested that the presence of fuel or fuel simulant did not in itself materially affect crack growth.

CONTENTS

	<u>Page</u>
1 INTRODUCTION	3
2 SPECIMEN	3
3 FUEL AND FUEL SIMULANT	4
4 TESTING RIG AND FATIGUE TESTING	4
5 RESULTS	5
6 DISCUSSION	5
7 CONCLUSIONS	6
Appendix Testing rig and associated equipment	7
Tables 1 and 2	9
References	11
Illustrations	Figures 1-7

1 INTRODUCTION

In the Concorde Major Fatigue Test, the presence of fuel in the aircraft tanks must be represented in order to achieve the required temperature gradients. For safety and other reasons a fuel simulant is used and it is necessary to establish the fatigue performance of structure wetted by fuel is not significantly affected by this substitution.

In a previous investigation¹, rotating bending fatigue tests of short duration on plain specimens, immersed in fuel and in fuel simulant at room temperature, showed no marked difference in endurance. However it was considered necessary to investigate the possibility that a difference might become apparent if the material were exposed to the liquids at elevated temperature for a comparatively long time during which a crack propagated under a representative sequence of loads.

This Report describes comparative fatigue crack propagation tests of about 1000h duration under a flight-by-flight load sequence on specimens immersed in jet fuel and in fuel simulant. Temperature conditions were represented very simply by maintaining the liquids at the maximum temperatures they attain in service and test respectively. In addition similar tests were conducted in air at room and elevated temperatures to provide a measure of the effects of immersion and temperature.

2 SPECIMEN

The specimens were made from CM002 aluminium alloy sheet (unclad RR58). The material was readily available in the T46 (pre-aged) condition and, although CM002 on the aircraft is not in this condition, it was considered suitable for comparative tests. The composition and room temperature tensile properties of the metal used are given in Table 1.

Fig.1 shows the dimensions of the specimens and details of the central crack starter which consisted of a 9.5mm diameter hole with a 2.5mm long spark eroded slot on each side. Two ladder (or breakwire) crack propagation gauges were bonded to each specimen, one on each side of the central notch. The specimens were positioned in the fatigue test rig as seen in Fig.2 with their ends clamped between 3.2mm mild steel end fittings by three rows of 12.5mm diameter bolts. The free length of the specimens was 762mm giving an effective length to width ratio of 3:1.

3 FUEL AND FUEL SIMULANT

The fuel used in the tests was Avtur 50 aviation kerosene conforming to specification D Eng RD2494.

The fuel simulant was Shell S7305C, a high grade mineral oil fortified by additives which enhance high temperature oxidation stability, reduce deposit forming tendencies and impart a degree of metal passivation. It is closely representative of fuel in both physical and chemical properties, but the flash point is higher than that of fuel. The leading physical and chemical properties are given in Table 2.

The batch of simulant for these tests was not new, having been used previously in tests designed to ensure that it was suitable for long term use in the Concorde Major Fatigue Test; its condition was representative of simulant which had been used for approximately one year in that test.

4 TESTING RIG AND FATIGUE TESTING

The testing rig (see Fig.2) applied a programme of axial tensile loads to simple crack propagation specimens. For tests in which specimens were immersed in fuel or fuel simulant the liquids were contained in baths which were clamped to the specimens (Fig.3). The specimens were heated by electric heating tape which was wrapped directly round the specimens for tests in air and round the liquid baths for tests in fuel or simulant. The testing rig and its associated equipment are described in detail in the Appendix.

Fig.4 shows the simplified flight by flight loading sequence which was applied and which represented a loading on fuselage structure under pressurisation and gust load cycles. A 20 minute dwell under maximum tensile load was included in each loading sequence to represent the cruise. The loading sequence was repeated until a crack had grown to a total length of approximately 100mm, i.e. 40% of the specimen width.

Three specimens were tested in each of four conditions:

- (1) In fuel at a constant temperature of 70^oC which is the maximum temperature reached in service.
- (2) In fuel simulant at a constant temperature of 90^o which is the maximum temperature reached in the Major Fatigue Test.
- (3) In air at a constant temperature of 90^oC.

(4) In air at room temperature.

Tests (3) and (4) were included in the investigation to provide an indication of the effect of elevated temperature, and, by comparison with tests (1) and (2), the effect of immersion.

Fatigue crack growth was measured using ladder (or breakwire) crack propagation gauges. The distances from the ends of the crack starter to the first wires of the gauges were measured on each specimen and the distances between the breakwires of the gauges were known.

As the cracks advanced successive wires of the gauges were broken and this was monitored by a trace recording of the gauge resistances. From this information the variation of total crack length with number of loading sequences was evaluated.

5 RESULTS

The variation of total crack length with number of load sequences is presented in Fig.5 for the four test conditions. For clarity, only the two extreme results for each condition are shown. A computer programme developed by McCartney and Cooper² was used to evaluate crack growth rates; this method uses spline functions to fit a curve to the data and hence calculate the growth rate curves. The results are plotted in Fig.6 for specimens tested in fuel and simulant and in Fig.7 for specimens tested in air. Again, only extreme values are plotted.

6 DISCUSSION

The primary aim of these tests was to establish whether there was any marked difference between crack propagation rates in fuel at 70°C and in fuel simulant at 90°C. In addition the effects of immersion and elevated temperature on crack rate were investigated.

Fig.6 shows that, at all crack lengths, crack growth rates in fuel simulant at 90°C were similar to those in fuel at 70°C and Fig.7 shows that crack rates in air were appreciably higher at 90°C than at room temperature.

An overall comparison of the four cases is obtained by considering the integrated effect of differences in crack rates on specimen lives. The table below shows the number of loading sequences to increase the total crack length from 14.5mm to 55mm, based on the logarithmic mean life from three tests at each condition.

Test condition	Life
In fuel at 70°C	1930
In fuel simulant at 90°C	1860
In air at 90°C	2120
In air at room temperature	2600

It is seen that lives in fuel and simulant differ by only about 4%. A similar life was also obtained in air at 90°C indicating that neither fuel nor simulant had much effect. The rather longer life in air at room temperature suggests that temperature was the only parameter which affected crack propagation in this investigation.

7 CONCLUSIONS

Fatigue crack propagation tests were carried out on CM002 sheet specimens which were immersed in jet fuel at 70°C and in fuel simulant at 90°C to simulate conditions in Concorde service and in the Concorde Major Fatigue Test respectively. Crack propagation rates observed were not significantly different. Comparison of these results with those of similar tests in air at 90°C and at room temperature suggested that the presence of fuel or fuel simulant did not in itself materially affect crack growth.

Appendix

TESTING RIG AND ASSOCIATED EQUIPMENT

Fig.2 shows part of the testing rig which was designed to apply a programme of loads to simple crack propagation specimens, some of which were immersed in fuel or fuel simulant at elevated temperature. In each unit of the rig an upper horizontal beam was supported from the floor by legs. From this beam two specimens and one hydraulic jack were suspended vertically with the jack positioned midway between the specimens and were connected at their lower ends by a floating lower horizontal beam. The upper and lower beams were each made from two 150mm × 75mm mild steel channels bolted together back to back with 25mm spacers between them to allow the end fittings of the specimens to be attached to the beams on the longitudinal centreline by a simple pin. The jack was also attached to the beams by pin ended fittings. Due to the dead weight of the rig components, the specimen, when nominally unloaded was under a tensile stress of approximately 1.6MN/m^2 .

The testing rig consisted of three units in which the jacks were connected to a common source of hydraulic pressure so that six specimens were simultaneously subjected to nominally the same loads. The mechanical loading programme was regulated by a Post Office type uniselector switch. The different load levels during each flight cycle were controlled by electro-mechanical selector valves and the amplitude of the fatigue loads was controlled by a Budenberg max-min electrical contact pressure gauge. A load cell was used to check the actual loads applied at each specimen position. Pressure relief valves were incorporated in the hydraulic circuit to ensure that overloads did not occur.

In the cases where specimens were tested in fuel or fuel simulant the liquid was contained in tanks clamped to the specimens as shown in Fig.3. The tanks were of welded aluminium alloy construction and were supported on the specimens by asbestos lined mild steel clamps. A neoprene seal prevented liquid escaping at the base of each tank, and a neoprene vapour seal, bonded to the specimen and the tank (see Fig.2), prevented the escape of vapour to the atmosphere. Any vapour which was produced during the tests was piped off to a stainless steel condensing coil and the condensate was fed to a header tank. The liquid level in this header tank was such that the fatigue cracks were always immersed. If the liquid level fell below the prescribed level the loading and heating were cut off.

Those specimens which were tested in fuel or fuel simulant were heated by electric heating tape which was wrapped around the liquid baths (Fig.2). In these tests, temperatures were monitored on the specimen by thermocouples attached near the central notch, and thermocouples located in the heating tape were used to control the temperatures.

In the tests carried out at 90°C in air the heating tape was wound directly around the specimens. Again temperatures were monitored by thermocouples on the specimen and controlled by thermocouples in the heating tape. Micro switches on the temperature recorders were set to prevent overheating.

During all tests crack propagation gauges were used to measure crack growth. These were positioned each side of the central notch as shown in Fig.1b. As a crack grew across a specimen and successive wires of the crack propagation gauges were broken so the electrical resistance of the gauges changed. The gauges were scanned automatically during alternate cycles and their resistances measured and presented on a Cambridge series 80 trace recorder. From this information the variation of fatigue crack length with number of loading cycles was obtained for each specimen.

Table 1CHEMICAL COMPOSITION AND TENSILE PROPERTIES OF CM002(a) Chemical composition

Element	% by weight	
	Min	Max
Cu	1.8	2.7
Mg	1.2	1.8
Si	0.15	0.25
Fe	0.9	1.4
Mn	-	0.2
Ni	0.8	1.4
Zn	-	0.1
Pb	-	0.05
Sn	-	0.05
Ti	-	0.2
Aluminium	-	Remainder

(b) Tensile properties

0.2% proof stress	264MN/m ²
UTS	400MN/m ²
Elongation	17.5%

REFERENCES

<u>No.</u>	<u>Author</u>	<u>Title, etc.</u>
1	-	Studies to develop a fuel simulant for Concorde Major Fatigue Test Rig. Shell International Petroleum (1972)
2	L.N. McCartney Mrs. P. Cooper	Computerised processing of fatigue crack propagation data. NPL Report Mat. App.23 (1972)

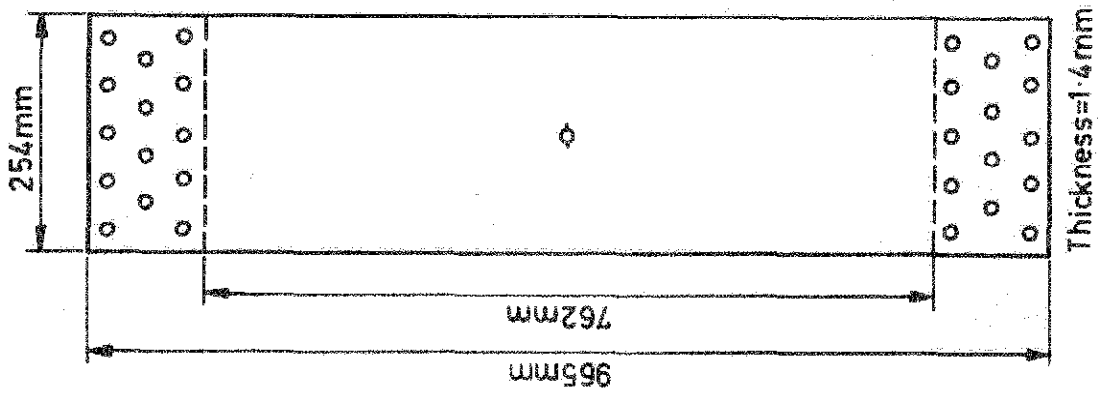

a Test specimen

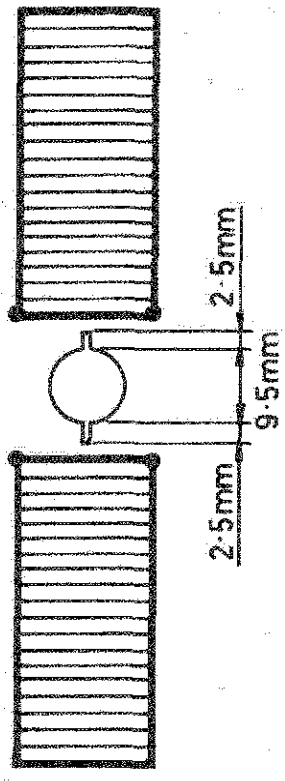

b Detail of central notch and position of crack propagation gauges

Fig. 1 Test specimen and crack propagation gauges

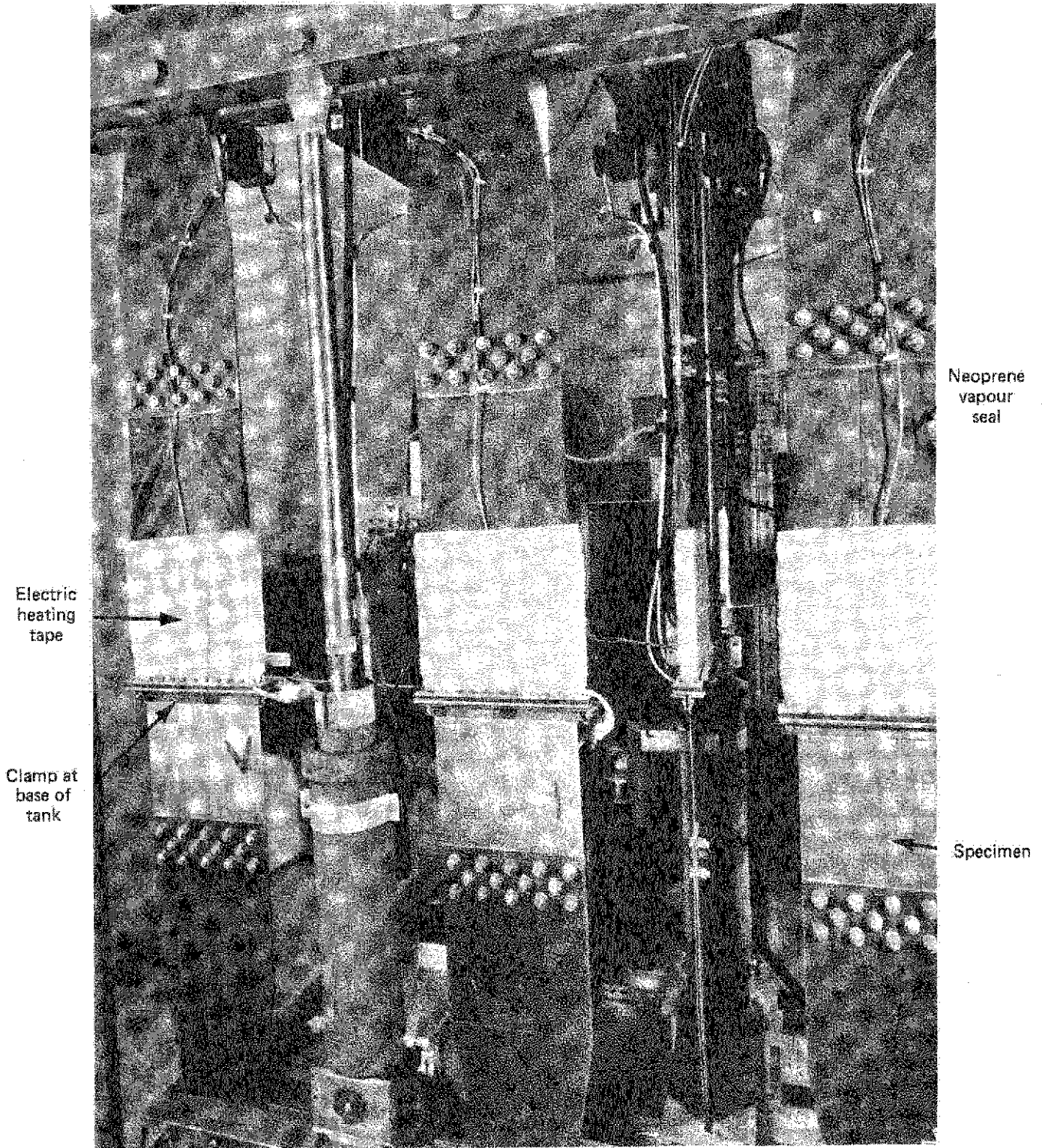

Fig.2 Fatigue test rig

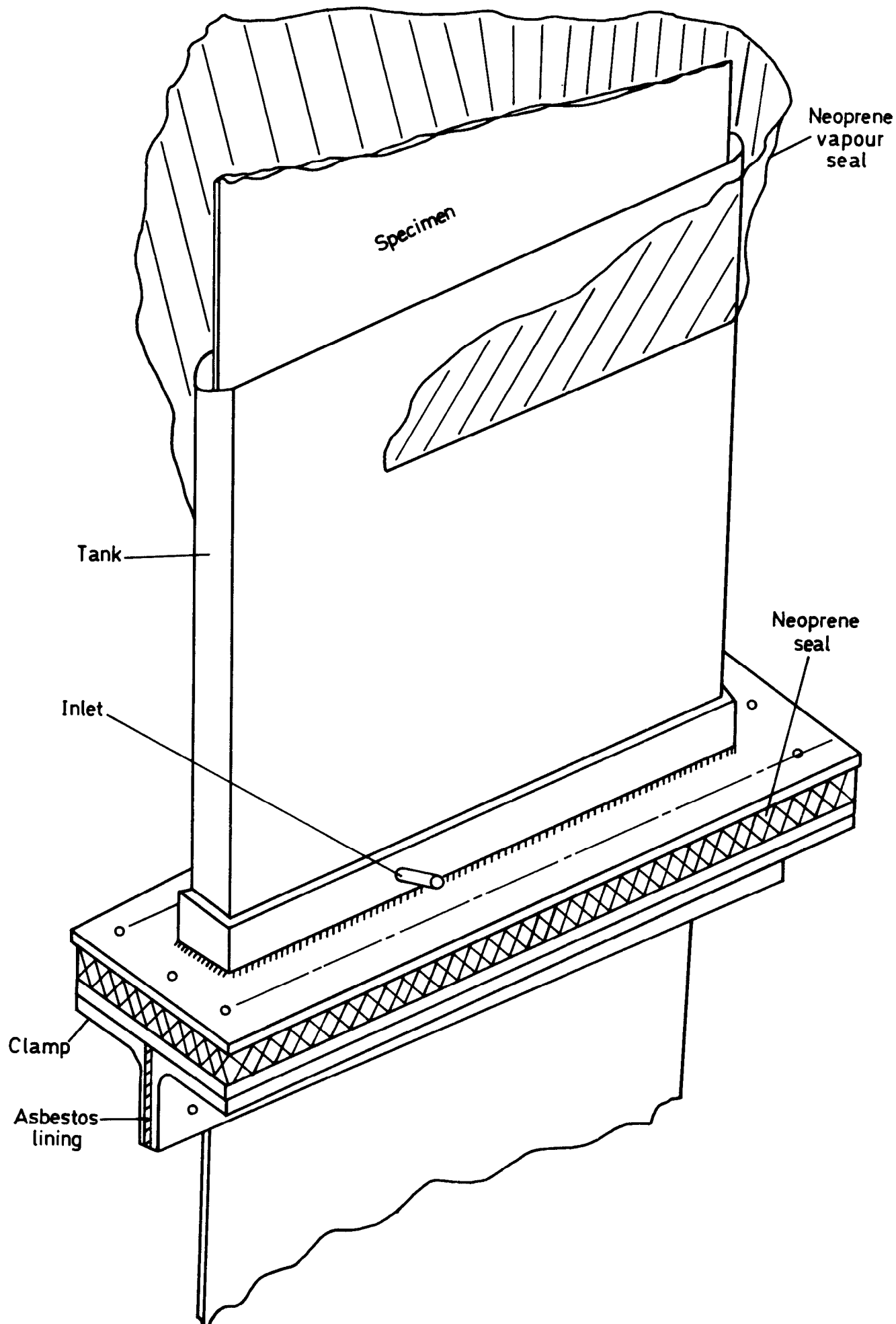

Fig. 3 Tank assembly used to contain fuel and fuel simulant during testing

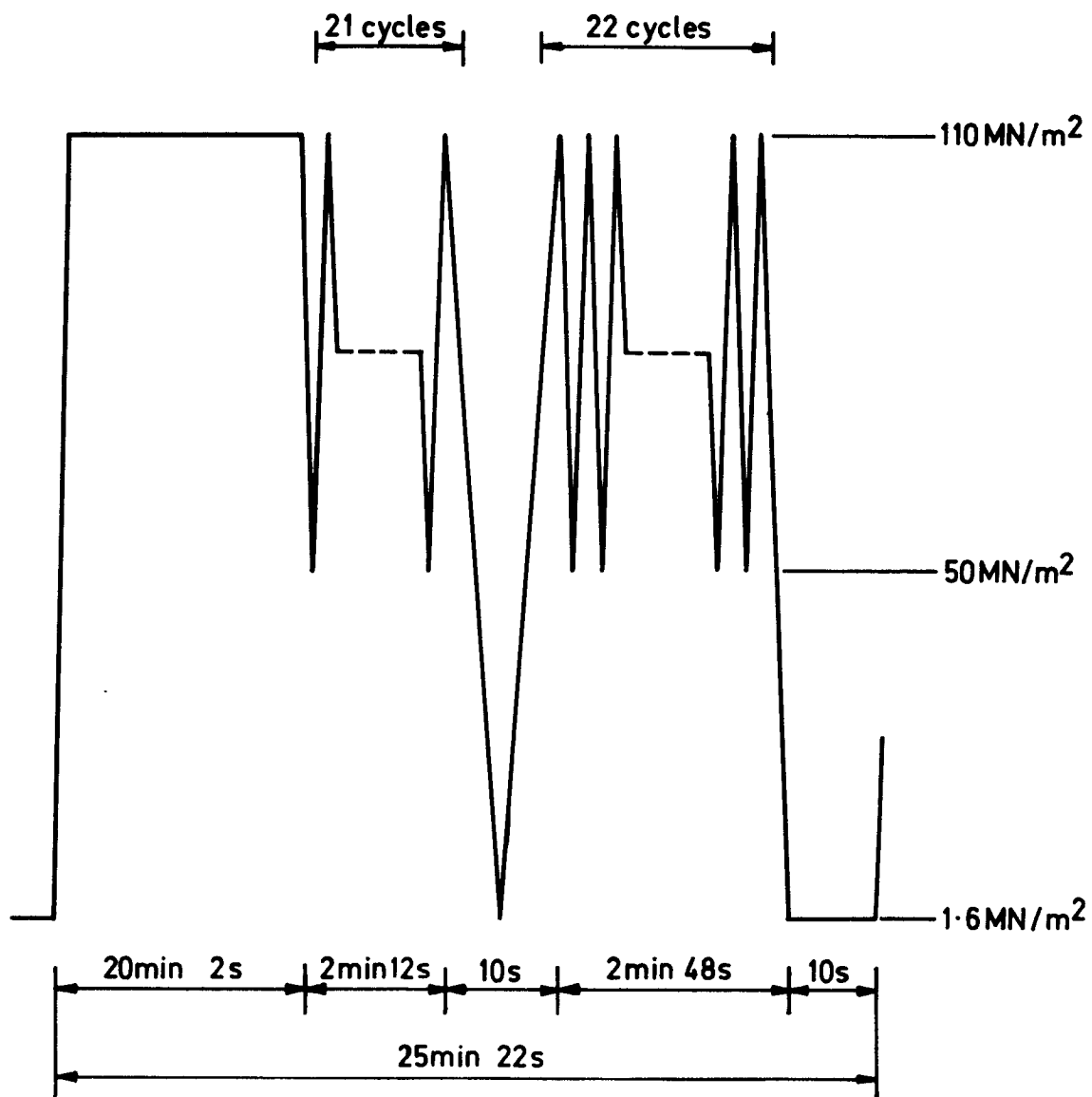

Fig. 4 Fatigue loading sequence

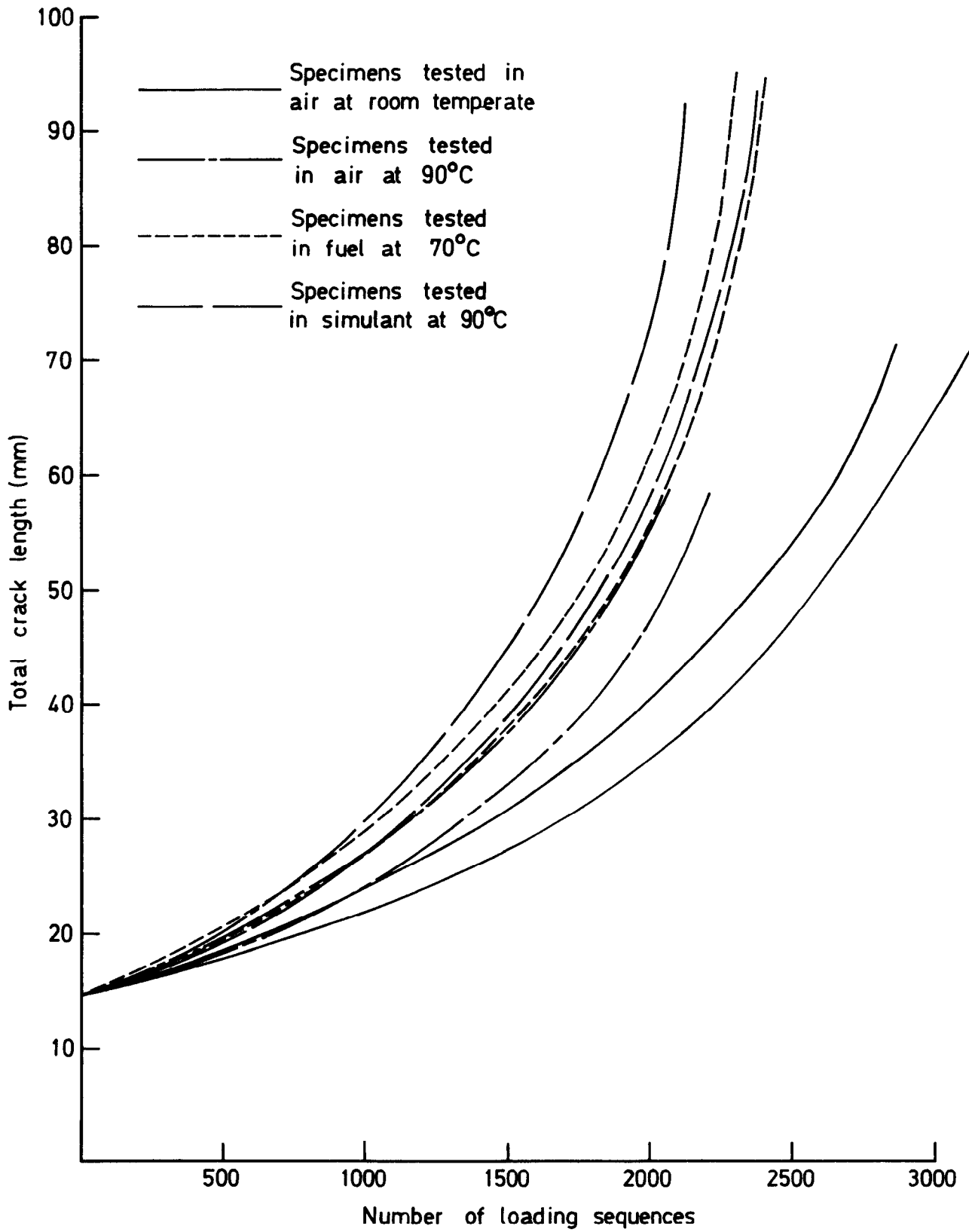

Fig.5 Fatigue crack length vs number of loading sequences

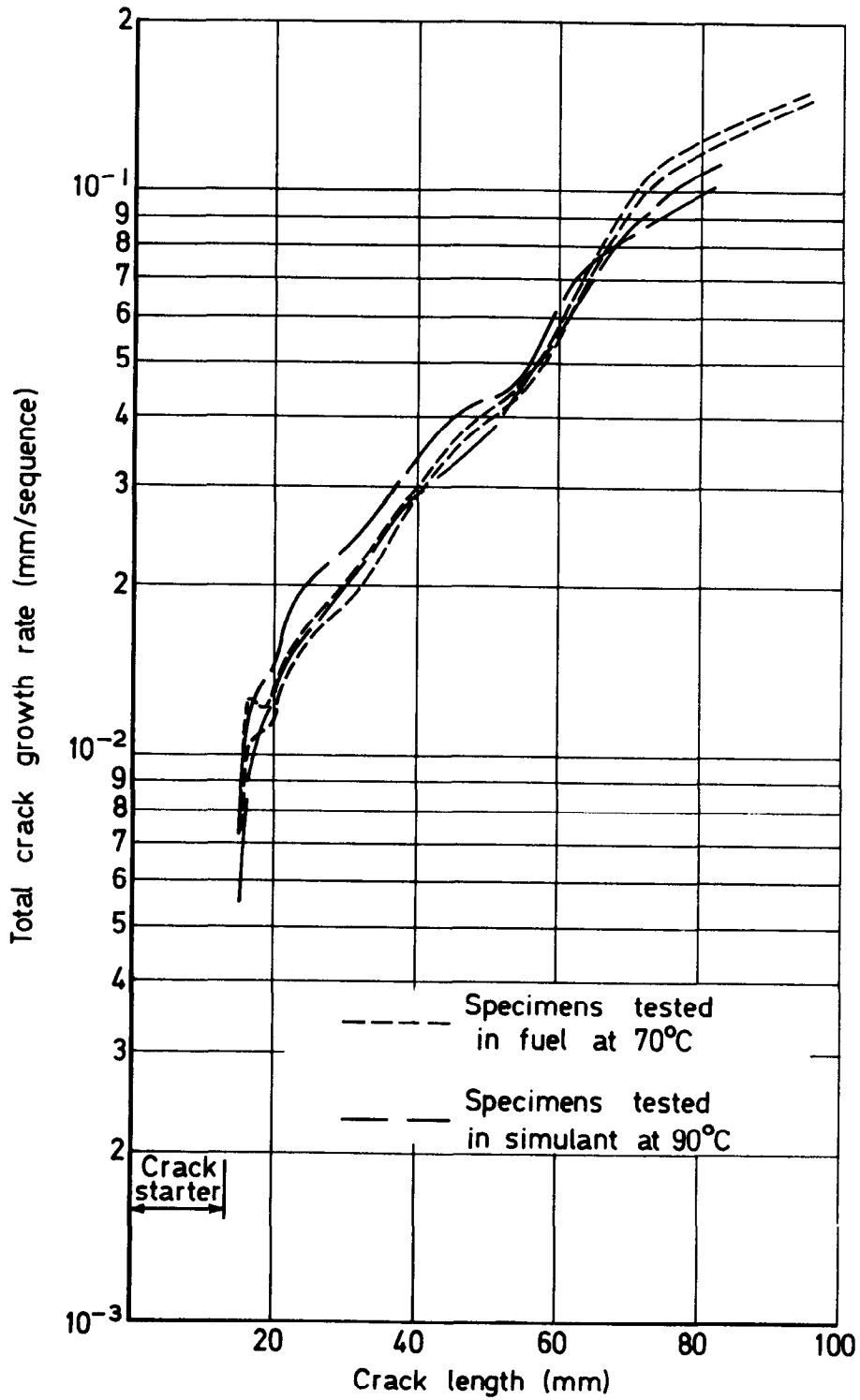

Fig.6 Crack growth rate vs crack length for specimens tested
 a) In fuel at 70°C b) In fuel simulant at 90°C

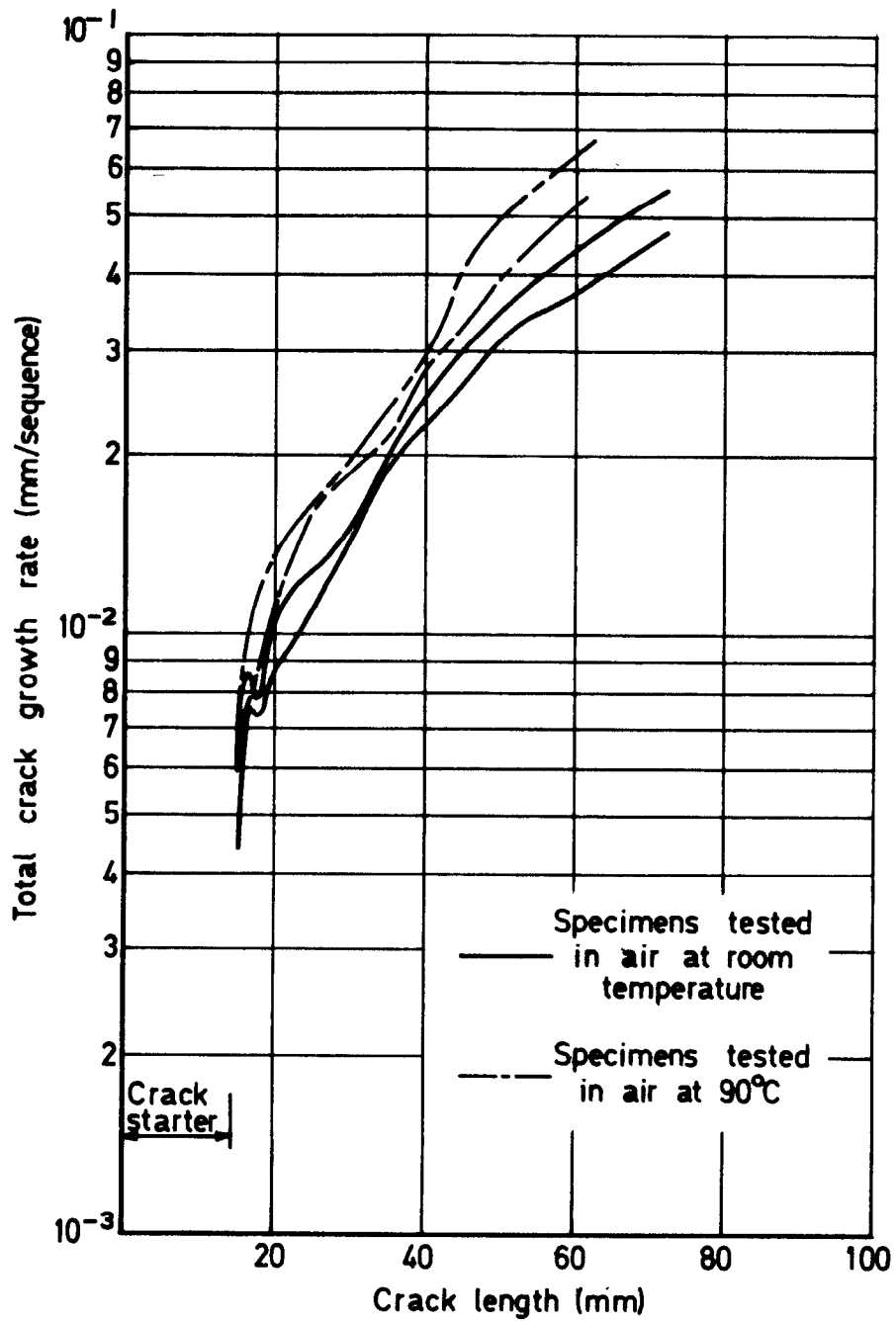

Fig. 7 Crack growth rate vs crack length for specimens tested
 a) In air at 90°C b) In air at room temperature

ARC CP No.1365
April 1976

539.219.2 :
539.388.1 :
669.715 :
665.743.3

Keates, F. E.
Mousley, R. F.

**A COMPARISON OF FATIGUE CRACK PROPAGATION RATES IN
CM002 (UNCLAD RR58) ALUMINIUM ALLOY IMMERSSED IN JET
FUEL AND A FUEL SIMULANT**

Fatigue crack propagation tests were conducted on CM002 (unclad RR58) aluminium alloy sheet under a flight-by-flight loading sequence. The specimens were immersed in jet fuel at 70°C and in fuel simulant at 90°C to simulate conditions in Concorde service and in the Concorde Major Fatigue Test respectively. No large difference in crack propagation was observed. Comparison with the results of similar tests in air at room temperature and at 90°C suggested that the presence of fuel or fuel simulant did not in itself materially affect crack growth.

ARC CP No.1365
April 1976

539.219.2 :
539.388.1 :
669.715 :
665.743.3

Keates, F. E.
Mousley, R. F.

**A COMPARISON OF FATIGUE CRACK PROPAGATION RATES IN
CM002 (UNCLAD RR58) ALUMINIUM ALLOY IMMERSSED IN JET
FUEL AND A FUEL SIMULANT**

Fatigue crack propagation tests were conducted on CM002 (unclad RR58) aluminium alloy sheet under a flight-by-flight loading sequence. The specimens were immersed in jet fuel at 70°C and in fuel simulant at 90°C to simulate conditions in Concorde service and in the Concorde Major Fatigue Test respectively. No large difference in crack propagation was observed. Comparison with the results of similar tests in air at room temperature and at 90°C suggested that the presence of fuel or fuel simulant did not in itself materially affect crack growth.

ARC CP No.1365
April 1976

539.219.2 :
539.388.1 :
669.715 :
665.743.3

Keates, F. E.
Mousley, R. F.

**A COMPARISON OF FATIGUE CRACK PROPAGATION RATES IN
CM002 (UNCLAD RR58) ALUMINIUM ALLOY IMMERSSED IN JET
FUEL AND A FUEL SIMULANT**

Fatigue crack propagation tests were conducted on CM002 (unclad RR58) aluminium alloy sheet under a flight-by-flight loading sequence. The specimens were immersed in jet fuel at 70°C and in fuel simulant at 90°C to simulate conditions in Concorde service and in the Concorde Major Fatigue Test respectively. No large difference in crack propagation was observed. Comparison with the results of similar tests in air at room temperature and at 90°C suggested that the presence of fuel or fuel simulant did not in itself materially affect crack growth.

ARC CP No.1365
April 1976

539.219.2 :
539.388.1 :
669.715 :
665.743.3

Keates, F. E.
Mousley, R. F.

**A COMPARISON OF FATIGUE CRACK PROPAGATION RATES IN
CM002 (UNCLAD RR58) ALUMINIUM ALLOY IMMERSSED IN JET
FUEL AND A FUEL SIMULANT**

Fatigue crack propagation tests were conducted on CM002 (unclad RR58) aluminium alloy sheet under a flight-by-flight loading sequence. The specimens were immersed in jet fuel at 70°C and in fuel simulant at 90°C to simulate conditions in Concorde service and in the Concorde Major Fatigue Test respectively. No large difference in crack propagation was observed. Comparison with the results of similar tests in air at room temperature and at 90°C suggested that the presence of fuel or fuel simulant did not in itself materially affect crack growth.

Cut here

DETACHABLE ABSTRACT CARDS

DETACHABLE ABSTRACT CARDS

Cut here

© *Crown copyright*

1977

Published by
HER MAJESTY'S STATIONERY OFFICE

Government Bookshops

49 High Holborn, London WC1V 6HB

13a Castle Street, Edinburgh EH2 3AR

41 The Hayes, Cardiff CF1 1JW

Brazennose Street, Manchester M60 8AS

Southey House, Wine Street, Bristol BS1 2BQ

258 Broad Street, Birmingham B1 2HE

80 Chichester Street, Belfast BT1 4JY

*Government Publications are also available
through booksellers*