

N.A.E.

R. & M. No. 2939

(6871)

A.R.C. Technical Report



MINISTRY OF SUPPLY

AERONAUTICAL RESEARCH COUNCIL
REPORTS AND MEMORANDA

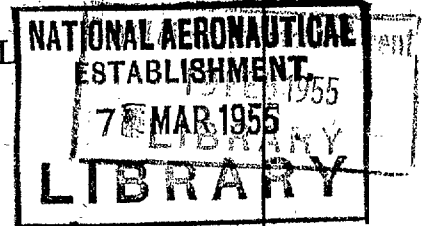

The Flexural Axis of Thin-walled Sections that have no Plane of Symmetry

By

D. WILLIAMS, D.Sc., A.M.I.Mech.E.

and

B. V. S. C. RAE, B.A.

Crown Copyright Reserved

LONDON: HER MAJESTY'S STATIONERY OFFICE

1955

PRICE TWO SHILLINGS NET

The Flexural Axis of Thin-walled Sections that have no Plane of Symmetry

By

D. WILLIAMS, D.Sc., A.M.I.Mech.E.

and

B. V. S. C. RAE, B.A.

COMMUNICATED BY THE PRINCIPAL DIRECTOR OF SCIENTIFIC RESEARCH (AIR),
MINISTRY OF SUPPLY

*Reports and Memoranda No. 2939**
May, 1943

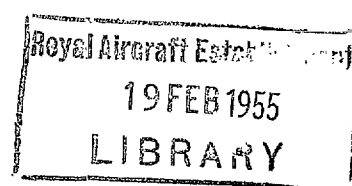

Summary.—A method of finding the flexural axis of unsymmetrical thin-walled sections is described that not only obviates the necessity for first finding the principal axes of inertia, but also simplifies the whole procedure.

1. The way to find the flexural axis of a thin hollow section with at least one axis of symmetry is now well known¹, but although a method of dealing with an asymmetrical section on much the same basis immediately suggests itself, it can be a very tedious and unsatisfactory method in practice. The saving of labour made possible by the method described here may be understood immediately by considering what happens physically in the case of a simple example of an asymmetrical section as compared with the behaviour of a section with one plane of symmetry.

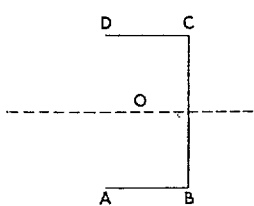

FIG. 1a.

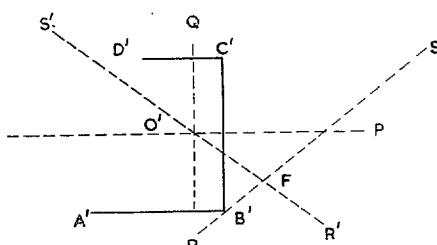

FIG. 1b.

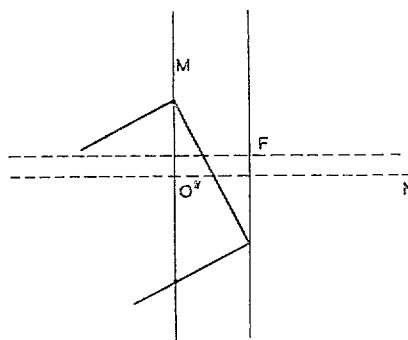

FIG. 1c.

Let the latter be represented by the channel section of Fig. 1a and the corresponding asymmetrical section by Fig. 1b. Each section has a flexural axis position such that if a transverse load is there applied the channel bends without twisting. If the load is a down load (*i.e.*, parallel to the web of the channel) we know that the symmetrical section will be displaced *in*

* R.A.E. Report S.M.E. 3248, received 6th July, 1943.

the direction of the applied load but the asymmetrical section will not. To make the asymmetrical section bend in the direction of the applied force that force must be applied along one of the two mutually perpendicular principal axes of inertia, and the method of finding the flexural axis, referred to above as immediately suggesting itself, consists in first finding the directions of these principal axes ($O''M$ and $O''N$ say of Fig. 1c) and then considering the two cases of pure bending about each of them. The two lines of action of the resultant forces thus obtained intersect at the flexural axis, since each must pass through it. The task of finding the principal axes is laborious in itself and also it can be seen from Fig. 1c that the section is in an awkward position relative to the axes for calculating the accompanying shear stresses.

The method advocated here is to consider bending about the axes $O'P$ and $O'Q$ of Fig. 1b, recognising that to ensure bending about $O'P$, for example, the direction of the transverse force will not be along the perpendicular to $O'P$ but at an angle to it. That angle is found by the simple expedient of assuming that the force is applied at the correct angle to give bending about $O'P$ and then calculating the shears along the three sides $A'B'$, $B'C'$ and $C'D'$ by the standard method. The resultant of these shear forces is a single shear force whose magnitude and line of action can be readily calculated.

The section is next considered as bending about the neutral axis $O'Q$ and the new line of action $R'S'$ of the resultant of the shears along the three sides of the channel obtained. The intersection F of these two lines of action locates the flexural axis.

It is noted that the principal axes need not be known and that the bending stresses are readily obtained in virtue of the fact that the sides of the channel are in each case either parallel or perpendicular to the neutral axis.

2. For a closed section the same method is applicable with, of course, the usual added complication that there is no point at which the shear stress is known, whereas it is known at the free edges of the open section.

In that case, as described in Ref. 1 for symmetrical sections, the shear stresses must be obtained in terms of an unknown shear stress τ_0 at a convenient point on the periphery of the section. By putting in the condition of zero twist, *i.e.*, by making the integral $\int \tau_0 ds$ (shear stress multiplied by element of periphery) round the whole boundary equal to zero, or, what amounts to the same thing, making the shear strain energy a minimum, the value of τ_0 is obtained and hence the line of action of the resultant shear.

3. As an example, the above method is applied, in an appendix, to the case of the asymmetrical channel, and, as that is a section that is fairly common in practice, the work is followed by a diagram that allows the flexural axis position for various proportions of the three sides of the channel to be read off.

REFERENCE

No.	Author	Title, etc.
1	D. Williams	Behaviour in Bending of Thin-walled Tubes and Channels. R. & M. 1669. February, 1935.

APPENDIX

Example

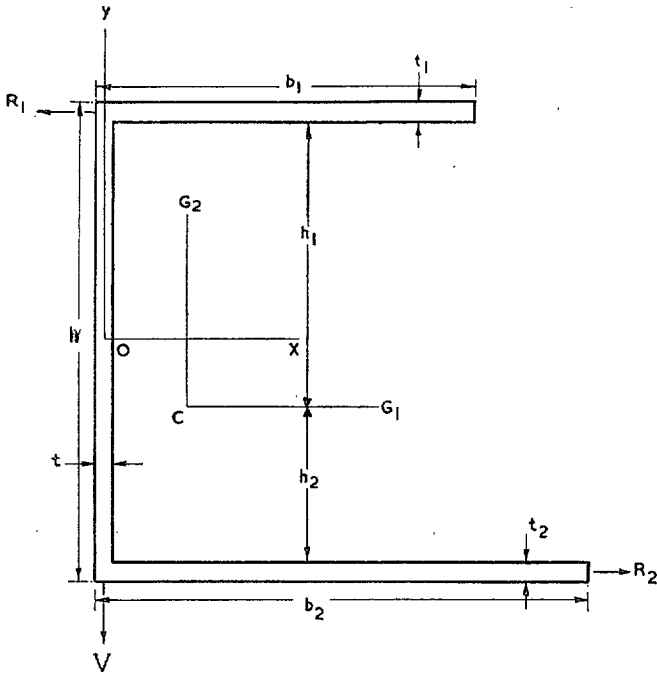

Referring to the figure

let h be depth of web.

b_1, b_2 widths of flanges,

t_1, t_2, t thicknesses of flanges and web

Ox, Oy axes through middle point of the web

C centre of gravity (\bar{x}, \bar{y})

CG_1, CG_2 parallel axes through C

I_1, I_2 moment of inertia of section about CG_1, CG_2

$$\bar{x} = \frac{\frac{t_1 b_1^2}{2} + \frac{t_2 b_2^2}{2}}{t_1 b_1 + t h + t_2 b_2},$$

$$\bar{y} = \frac{\frac{h}{2}(t_1 b_1 - t_2 b_2)}{t_1 b_1 + t h + t_2 b_2}.$$

Let us first apply loads so as to bend the section about the line CG_1 , *i.e.*, the bending takes place in the plane of the web. Let V, R_1, R_2 be the resultant shearing forces in the web and flanges as shown. We shall find R_1, R_2 in terms of V by using the well-known formulae for shear stress in a beam.

For the top flange, the shear stress at distance x from the root of the flange

$$= \frac{V h_1 (b_1 - x)}{I_1}.$$

The total shear force R_1 in the top flange is obtained by integrating the above expression from 0 to b_1 , *i.e.*,

$$R_1 = \frac{V h_1 t_1}{I_1} \frac{b_1^2}{2}.$$

Similarly the total shearing force R_2 in the bottom flange is given by

$$R_2 = \frac{V h_2 t_2 b_2^2}{2 I_1}.$$

Now we know that if coplanar forces X_r, Y_r act at points x_r, y_r in the xy -plane the line of action of their resultant is given by*

$$y \Sigma X_r - x \Sigma Y_r + \Sigma(x_r Y_r - y_r X_r) = 0,$$

so that the line of action of the resultant force referred to Ox, Oy is

$$y(h_2 t_2 b_2^2 - h_1 t_1 b_1^2) + 2I_1 x + \frac{h}{2} (t_2 h_2 b_2^2 + t_1 h_1 b_1^2) = 0. \quad \dots \quad (1)$$

Now consider bending about CG_2

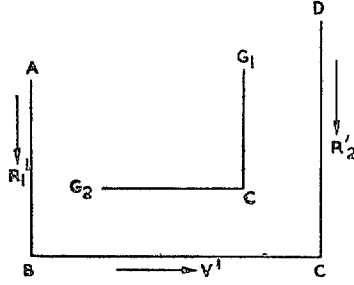

R_1^1, R_2^1 are now in the same direction. As before

$$R_1^1 = \frac{V^{11} t_1 b_1^2}{6I_2} (2b_1 - 3\bar{x}),$$

$$R_2^1 = \frac{V^{11} t_2 b_2^2}{6I_2} (2b_2 - 3\bar{x}),$$

where V^{11} is the total shearing force in the section perpendicular to the axis of bending, i.e.,
 $V^{11} = R_1^1 + R_2^1$.

At B, shear flux (i.e., shear stress \times thickness)

$$= \frac{V^{11} t_1}{2I_2} (b_1^2 - 2\bar{x}b_1),$$

at C, shear flux

$$= \frac{-V^{11} t_2}{2I_2} (b_2^2 - 2\bar{x}b_2).$$

Mean value of shear flux along BC

$$= \frac{V^{11}}{4I_2} \{t_1 b_1^2 - t_2 b_2^2 - 2\bar{x}(t_1 b_1 - t_2 b_2)\}.$$

Since the shear varies linearly along BC

we have
$$V^1 = \frac{hV^{11}}{4I_2} \{t_1 b_1^2 - t_2 b_2^2 - 2\bar{x}(t_1 b_1 - t_2 b_2)\}.$$

The line of action of the resultant force is therefore

$$\begin{aligned} & 2y\{t_2 b_2^2(2b_2 - 3\bar{x}) + t_1 b_1^2(2b_1 - 3\bar{x})\} \\ & + 3hx\{t_2 b_2(b_2 - 2\bar{x}) - t_1 b_1(b_1 - 2\bar{x})\} \\ & + h\{t_2 b_2^2(2b_2 - 3\bar{x}) - t_1 b_1^2(2b_1 - 3\bar{x})\} = 0. \quad \dots \quad (2) \end{aligned}$$

*For, a force X_r, Y_r at point x_r, y_r is equivalent to a force X_r, Y_r at the origin, together with a couple $x_r Y_r - y_r X_r$ in the plane. Reducing all the forces to equivalent forces and couples at a point x^1, y^1 , we obtain that the forces X_r, Y_r at x_r, y_r are equivalent to forces X_r, Y_r and couples $\Sigma\{(x_r - x^1)Y_r - (y_r - y^1)X_r\}$ in the plane. If x^1, y^1 lies on the resultant of the forces X_r, Y_r at (x_r, y_r) , then the couple $\Sigma\{(x_r - x^1)Y_r - (y_r - y^1)X_r\} = 0$, i.e., $y^1 \Sigma X_r - x^1 \Sigma Y_r + \Sigma(x_r Y_r - y_r X_r) = 0$. Changing into current co-ordinates, the equation of the line of action of the resultant of the coplanar system of forces X_r, Y_r at (x_r, y_r) is given by $y \Sigma X_r - x \Sigma Y_r + \Sigma(x_r Y_r - y_r X_r) = 0$.

When the thickness is constant round the section, i.e., $t_1 = t_2 = t$

$$\begin{aligned} \bar{x} &= \frac{(b_1^2 + b_2^2)}{2(b_1 + h + b_2)} ; & \bar{y} &= \frac{(h/2)(b_1 - b_2)}{(b_1 + h + b_2)} \\ h_1 &= \frac{h(2b_2 + h)}{2(b_1 + h + b_2)} ; & h_2 &= \frac{h(2b_1 + h)}{2(b_1 + h + b_2)} \\ I_1 &= \frac{th^2}{12(b_1 + h + b_2)} \left\{ h^2 + 4h(b_1 + b_2) + 12b_1b_2 \right\} \\ I_2 &= \frac{t}{12(b_1 + h + b_2)} \left\{ (b_1 + b_2)^4 - 12b_1^2b_2^2 + 4h(b_1^3 + b_2^3) \right\} . \end{aligned}$$

Substituting these, and putting $\lambda = b_1/h$, $\mu = b_2/h$, the equations (1) and (2) become

$$6y(\mu - \lambda)(\mu + \lambda + 2\lambda\mu) + 2x\{1 + 4(\lambda + \mu) + 12\lambda\mu\} + 3h\{\lambda^2 + \mu^2 + 2\lambda\mu(\lambda + \mu)\} = 0, \quad \dots \dots \dots (3)$$

$$2y\{(\lambda + \mu)^4 - 12\lambda^2\mu^2 + 4(\lambda^3 + \mu^3)\} + 6x(\mu - \lambda)(\lambda + \mu + 2\lambda\mu) + h\{(\mu^2 - \lambda^2)(\mu^2 + \lambda^2 + 4\lambda\mu) + 4(\mu^3 - \lambda^3)\} = 0. \quad \dots \dots \dots (4)$$

We can, if we wish, solve for x/h , y/h to obtain the co-ordinates of the flexural centre directly, but the resulting expressions are cumbrous; the point is more easily found as the intersection of the two lines

$$\frac{x/h}{a_1} + \frac{y/h}{b_1} + 1 = 0, \quad \dots \dots \dots (5)$$

$$\frac{x/h}{a_2} + \frac{y/h}{b_2} + 1 = 0, \quad \dots \dots \dots (6)$$

where

$$\begin{aligned} a_1 &= \frac{3\{\lambda^2 + \mu^2 + 2\lambda\mu(\lambda + \mu)\}}{2\{1 + 4(\lambda + \mu) + 12\lambda\mu\}}, \\ b_1 &= \frac{\lambda^2 + \mu^2 + 2\lambda\mu(\lambda + \mu)}{2(\mu - \lambda)(\mu + \lambda + 2\lambda\mu)}, \\ a_2 &= \frac{\{(\mu^2 - \lambda^2)(\mu^2 + \lambda^2 + 4\lambda\mu) + 4(\mu^3 - \lambda^3)\}}{6(\mu - \lambda)(\mu + \lambda + 2\lambda\mu)} \\ b_2 &= \frac{\{(\mu^2 - \lambda^2)(\mu^2 + \lambda^2 + 4\lambda\mu) + 4(\mu^3 - \lambda^3)\}}{2\{(\lambda + \mu)^4 - 12\lambda^2\mu^2 + 4(\lambda^3 + \mu^3)\}}. \end{aligned}$$

Here $-a_1h$, $-b_1h$ are the intercepts made by the straight line (5) on the x - and y -axes respectively; $-a_2h$, $-b_2h$ are the corresponding intercepts made by the line (6). The intersection of the two lines is found graphically.

The method can be applied to any particular line section by choosing two suitable axes of bending in each case as shown in the diagrams.



Convenient axes (through centroid) shown dotted.

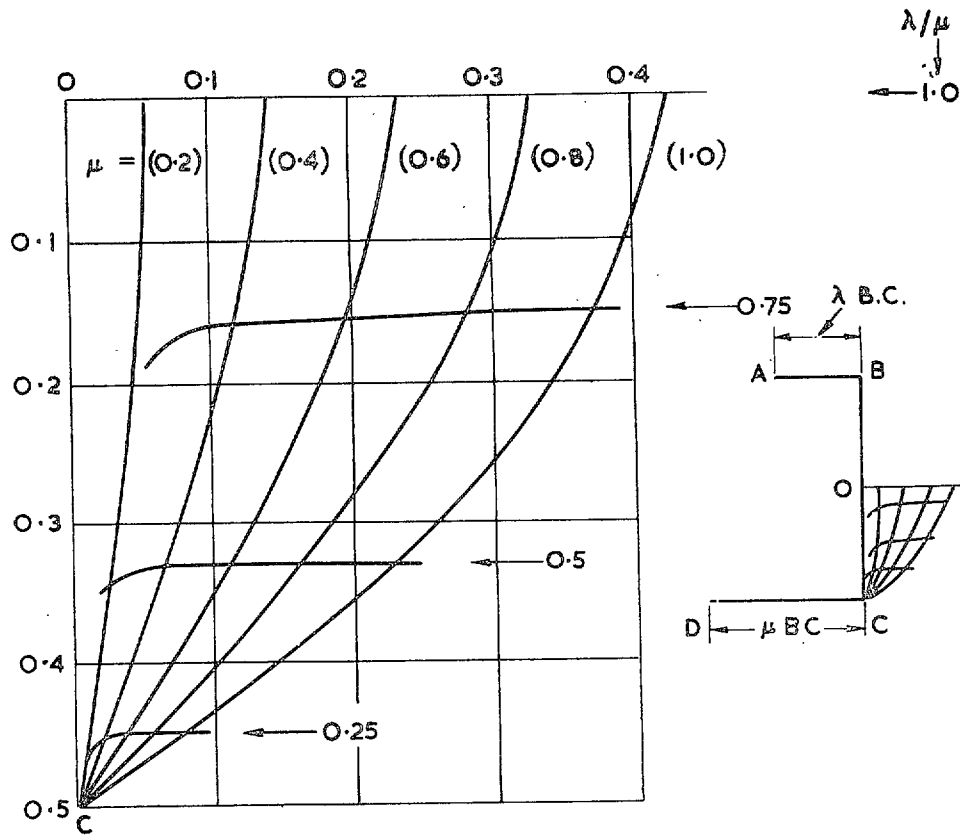

Flexural axis chart.

Publications of the Aeronautical Research Council

ANNUAL TECHNICAL REPORTS OF THE AERONAUTICAL RESEARCH COUNCIL (BOUND VOLUMES)

- 1936 Vol. I. Aerodynamics General, Performance, Airscrews, Flutter and Spinning. 40s. (41s. 1d.)
Vol. II. Stability and Control, Structures, Seaplanes, Engines, etc. 50s. (51s. 1d.)
- 1937 Vol. I. Aerodynamics General, Performance, Airscrews, Flutter and Spinning. 40s. (41s. 1d.)
Vol. II. Stability and Control, Structures, Seaplanes, Engines, etc. 60s. (61s. 1d.)
- 1938 Vol. I. Aerodynamics General, Performance, Airscrews. 50s. (51s. 1d.)
Vol. II. Stability and Control, Flutter, Structures, Seaplanes, Wind Tunnels, Materials. 30s. (31s. 1d.)
- 1939 Vol. I. Aerodynamics General, Performance, Airscrews, Engines. 50s. (51s. 1d.)
Vol. II. Stability and Control, Flutter and Vibration, Instruments, Structures, Seaplanes, etc. 63s. (64s. 2d.)
- 1940 Aero and Hydrodynamics, Aerofoils, Airscrews, Engines, Flutter, Icing, Stability and Control, Structures, and a miscellaneous section. 50s. (51s. 1d.)
- 1941 Aero and Hydrodynamics, Aerofoils, Airscrews, Engines, Flutter, Stability and Control, Structures. 63s. (64s. 2d.)
- 1942 Vol. I. Aero and Hydrodynamics, Aerofoils, Airscrews, Engines. 75s. (76s. 3d.)
Vol. II. Noise, Parachutes, Stability and Control, Structures, Vibration, Wind Tunnels 47s. 6d. (48s. 7d.)
- 1943 Vol. I. Aerodynamics, Aerofoils, Airscrews. 80s. (81s. 4d.)
Vol. II. Engines, Flutter, Materials, Parachutes, Performance, Stability and Control, Structures. 90s. (91s. 6d.)
- 1944 Vol. I. Aero and Hydrodynamics, Aerofoils, Aircraft, Airscrews, Controls. 84s. (85s. 8d.)
Vol. II. Flutter and Vibration, Materials, Miscellaneous, Navigation, Parachutes, Performance, Plates and Panels, Stability, Structures, Test Equipment, Wind Tunnels. 84s. (85s. 8d.)

Annual Reports of the Aeronautical Research Council—

1933-34	1s. 6d. (1s. 8d.)	1937	2s. (2s. 2d.)
1934-35	1s. 6d. (1s. 8d.)	1938	1s. 6d. (1s. 8d.)
April 1, 1935 to Dec. 31, 1936	4s. (4s. 4d.)	1939-48	3s. (3s. 2d.)

Index to all Reports and Memoranda published in the Annual Technical Reports, and separately—

April, 1950 R. & M. No. 2600. 2s. 6d. (2s. 7½d.)

Author Index to all Reports and Memoranda of the Aeronautical Research Council—

1909-1949. R. & M. No. 2570. 15s. (15s. 3d.)

Indexes to the Technical Reports of the Aeronautical Research Council—

December 1, 1936 — June 30, 1939.	R. & M. No. 1850.	1s. 3d. (1s. 4½d.)
July 1, 1939 — June 30, 1945.	R. & M. No. 1950.	1s. (1s. 1½d.)
July 1, 1945 — June 30, 1946.	R. & M. No. 2050.	1s. (1s. 1½d.)
July 1, 1946 — December 31, 1946.	R. & M. No. 2150.	1s. 3d. (1s. 4½d.)
January 1, 1947 — June 30, 1947.	R. & M. No. 2250.	1s. 3d. (1s. 4½d.)
July, 1951.	R. & M. No. 2350.	1s. 9d. (1s. 10½d.)

Prices in brackets include postage.

Obtainable from

HER MAJESTY'S STATIONERY OFFICE

York House, Kingsway, London, W.C.2 : 423 Oxford Street, London, W.1 (Post Orders : P.O. Box 569, London, S.E.1) ; 13a Castle Street, Edinburgh 2 ; 39 King Street, Manchester 2 ; 2 Edmund Street, Birmingham 3 ; 109 St. Mary Street, Cardiff ; Tower Lane, Bristol, 1 ; 80 Chichester Street, Belfast, or through any bookseller

S.O. Code No. 23-2939