

**NATIONAL ADVISORY COMMITTEE
FOR AERONAUTICS**

TECHNICAL NOTE

11 DEC 1947

No. 1490

COMPARATIVE PERFORMANCE OF TWO VANELESS DIFFUSERS
DESIGNED WITH DIFFERENT RATES OF PASSAGE
CURVATURE FOR MIXED-FLOW IMPELLERS

By Frank J. Barina

Flight Propulsion Research Laboratory
Cleveland, Ohio

FOR REFERENCE

NOT TO BE TAKEN FROM THIS ROOM



Washington
November 1947

NACA LIBRARY
LANGLEY MEMORIAL AERONAUTICAL
LABORATORY
Langley Field, Va.



3 1176 01425 8645

NATIONAL ADVISORY COMMITTEE FOR AERONAUTICS

TECHNICAL NOTE NO. 1490

COMPARATIVE PERFORMANCE OF TWO VANELESS DIFFUSERS
DESIGNED WITH DIFFERENT RATES OF PASSAGE
CURVATURE FOR MIXED-FLOW IMPELLERS

By Frank J. Barina

SUMMARY

The effect on diffuser performance of the passage curvature of two vaneless diffusers designed with a 6° equivalent-cone divergence angle along a logarithmic-spiral path was investigated in combination with two mixed-flow impellers. The diffuser performance is based on the ratio of the over-all adiabatic efficiency of the compressor to the impeller adiabatic efficiency. The curves at actual impeller tip speeds of 700 and 1200 feet per second are representative of the performance for the speed range investigated. The peak over-all adiabatic efficiency is compared with the corresponding diffuser efficiency.

The large difference in the passage curvature of the two vaneless diffusers made no appreciable difference in diffuser performance at the peak compressor efficiency for the range of speeds investigated.

INTRODUCTION

During an investigation of the performance characteristics of mixed-flow impellers, a program was simultaneously conducted on vaneless diffusers to find means of taking full advantage of the inherently high efficiency, large flow capacity, and wide operating range of the mixed-flow impellers. Vaneless diffusers designed by the method of reference 1 gave efficiencies as high or higher than those of a vaned diffuser previously investigated with the same impeller and maintained the usual vaneless-diffuser characteristics of a flat performance curve and a wide operating range. The rear plate of the diffusers described in reference 1 was designed to continue approximately the impeller-discharge angle in the axial direction for most of the radius. This configuration caused the complete compressor to have a great axial depth.

A considerable reduction in the axial depth can be achieved by curving both the front and rear plates of the diffuser to reduce the axial component of flow as rapidly as possible. This curvature, however, introduces another problem in the design of vaneless diffusers because flow separation is likely to occur along the front plate of the diffuser unless the passage area is rapidly reduced in the direction of flow. The optimum value of the contraction ratio for the transition section would probably be considerably less than the optimum value of 0.72 reported in reference 1. The recommendations concerning the contraction ratio in reference 1 were therefore considered inapplicable to a vaneless-diffuser design that had a curved transition section.

The performance of two 34-inch-diameter vaneless diffusers designed by the method of reference 1 to match similar mixed-flow impellers is compared. These diffusers have a large difference in passage curvature that is not considered in the design method. The comparative performance thus extends the information available on the application of the design method of vaneless diffusers.

APPARATUS AND PROCEDURE

Diffusers

Two vaneless diffusers, designated A and B, were designed to match two mixed-flow impellers according to the design method of reference 1. Each diffuser had a 6° equivalent cone divergence angle along a logarithmic spiral and an outside diameter of 34 inches. A dimensional comparison of the passage curvatures of the vaneless diffusers is made in figure 1. The configuration of diffuser A is the same as that used in reference 1 in which $\lambda = 0.72$. The quantity λ is the ratio of the exit-passage (throat) width of the transition section to the entrance-passage width of the transition section. Diffuser A maintains the axial discharge angle of the impeller for a greater part of the diameter before turning the air into a radial direction. Diffuser B changes the direction of the flow leaving the impeller to a radial direction before the air enters the diffuser proper. The profile of the rear plate at the transition section is formed by a circular arc. The profile of the front plate at this section is a straight line tangent to the impeller front shroud and to another arc at the diffuser entrance. The transition section of this diffuser uses a gentle decrease in flow area, which extends over the entire passage curvature. Because of this area reduction, the value of λ for diffuser B is 0.52. The ratio of the flow area at the outlet of the transition section to the flow area at the entrance of this section is 0.94 for diffuser A and 0.80 for diffuser B.

Impellers

The mixed-flow impeller B is shown in figure 2; mixed-flow impeller A is similar in appearance. Each of the impellers has 25 blades. A dimensional comparison of these impellers is made in the following table:

	Impeller	
	A	B
Outside diameter, in.	11.24	11.36
Inlet diameter, in.	8.25	8.25
Inlet hub diameter, in.	3.68	3.68
Axial depth, in.	3.75	4.16
Blade height at outlet, in.76	1.12
Axial discharge angle, deg	30	35

Experimental Setup

The performance of compressors A and B was determined in the variable-component rig in accordance with the methods of reference 2. Each impeller installation was made with a clearance of 0.035 inch measured statically with respect to the stationary front shroud and with the impeller in maximum-thrust position. (See fig. 1.) A 600-horsepower aircraft engine in conjunction with a speed increaser was used to drive the test rig.

Instrumentation

The accuracy of the measurements during stable operating conditions is estimated to be as follows:

Temperature, °F	±0.5
Pressure, in. Hg	±0.02
Pressure surveys, in. Hg	±0.1
Speed, percent	±0.5

Total-pressure tubes for surveys across the impeller outlet were located approximately 1/4 inch from the impeller tip and parallel to the blades. The transition section of the diffuser was divided into four equal segments, and the total-pressure surveys were taken at the center point of each of these segments. Some readings were taken during unstable flow conditions by recording the average of the fluctuating pressures, but these data were not used in the performance analysis. The total-pressure-survey tube was

5/32 inch in diameter and plugged at one end. A 0.020-inch-diameter hole was drilled in the wall of this tube near the plugged end.

The impeller tip speed was maintained at the desired constant value with the aid of a speed strip and a 60-cycle stroboscopic light. Frequent speed checks were made with a revolution counter and a stop watch.

Experimental Procedure

The investigation of the compressors was conducted according to the methods of reference 2. A method of experimental procedure similar to that outlined in reference 1 was used for compressor B. Compressor A was run at actual impeller tip speeds of 700, 900, 1100, and 1200 feet per second. Compressor B was run at actual impeller tip speeds of 700 to 1200 feet per second at increments of 100 feet per second. Room-temperature inlet air was used for these investigations.

Computation

The over-all compressor performance was determined according to the method of reference 2. Performance characteristics of the mixed-flow impellers were based on the arithmetical mean of the total-pressure surveys at the impeller tip. Because the compressor installations were enclosed in an insulated system, the total temperature measured in the outlet pipe was assumed to be the same as that at the impeller-outlet station. The diffuser efficiency, used to evaluate the performance of the vaneless diffusers, is defined as the ratio of the over-all adiabatic efficiency of the compressor to the impeller adiabatic efficiency.

RESULTS AND DISCUSSION

Adiabatic efficiency η_{ad} at actual impeller tip speeds of 700 and 1200 feet per second is shown as a function of the load coefficient Q/n (where: Q , volume flow, cu ft/sec; n , impeller speed, rps) in figures 3 and 4 for compressors A and B. The parameter Q/n was used because reference 1 showed that the flow conditions described by this parameter determined to a large extent the performance of the diffuser. Over the speed range investigated, these curves are representative of the performance of the vaneless diffusers.

The variation of diffuser efficiency with the load-coefficient parameter Q/n is shown in figure 5 at actual impeller tip speeds of 700 and 1200 feet per second. The greatest error in these efficiencies arises from the inaccuracy of the impeller-performance determination. Both diffusers had a small variation in efficiency for the range of volume flow at each of these speeds. The efficiency of diffuser B could not be determined at the high load coefficients at a tip speed of 1200 feet per second because of the unstable operating characteristics of impeller B. A comparison of figures 3, 4, and 5 indicates that the efficiency of impeller B was less than that of impeller A at the high tip speeds.

The peak over-all adiabatic efficiencies and the corresponding diffuser efficiencies of the two compressors are plotted against the impeller tip speed in figure 6. The peak over-all efficiencies of the two compressors are approximately the same at 700 feet per second. As the tip speed is increased to 1200 feet per second, the efficiency of compressor B decreases rapidly in comparison with compressor A. Although at the highest speed there is a difference of 0.12 in peak over-all efficiency between the two compressors, there is very little difference in the efficiency of the two vaneless diffusers. This particular trend is also apparent at low speeds. The diffuser-efficiency curve thus shows that the performance of vaneless diffusers A and B was not affected appreciably at the peak over-all efficiencies by differences in diffuser-passage curvature and slight differences in the impellers. Inasmuch as the flow entering diffuser B was probably more turbulent than that entering diffuser A, owing to the difference in impeller performance, diffuser B was not benefited by the difference in impeller performance. Consequently, the curvature of diffuser B did not promote any appreciable disturbances to the flow.

SUMMARY OF RESULTS

An experimental investigation, conducted in a variable-component rig, of two vaneless diffusers of different passage curvatures, designed for similar mixed-flow impellers, showed that the large difference in passage curvature of these diffusers made no appreciable difference in diffuser performance at the peak compressor efficiency for the range of speeds investigated.

Flight Propulsion Research Laboratory,
National Advisory Committee for Aeronautics,
Cleveland, Ohio, June 23, 1947.

1. Brown, W. Byron, and Bradshaw Guy R.: Method of Designing Vaneless Diffusers and Experimental Investigation of Certain Undetermined Parameters. NACA TN No. 1426, 1947.
2. Ellerbrock, Herman H., Jr., and Goldstein, Arthur W.: Principles and Methods of Rating and Testing Centrifugal Superchargers. NACA ARR, Feb. 1942.

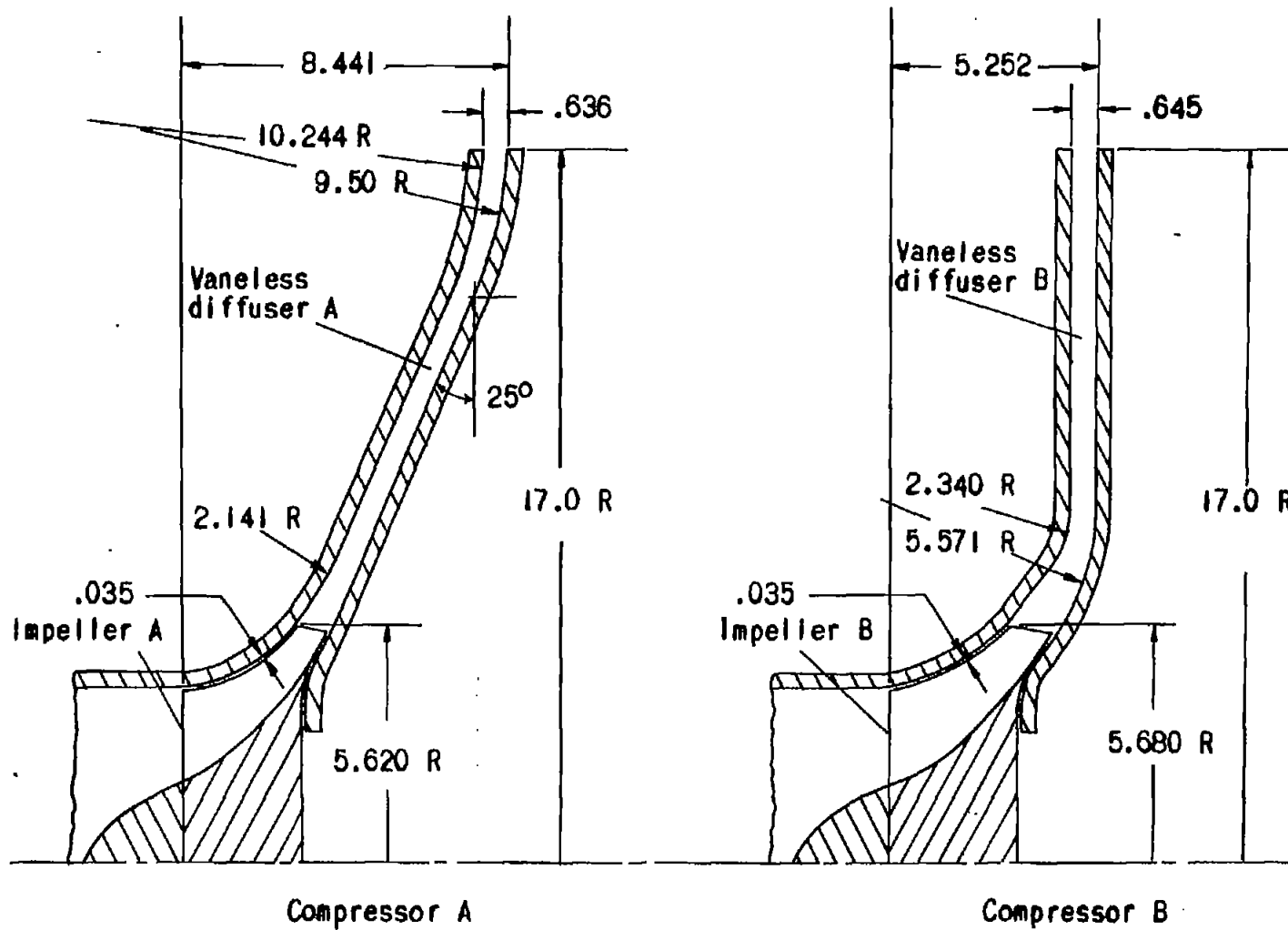

NATIONAL ADVISORY
COMMITTEE FOR AERONAUTICS

Figure 1. - Dimensional comparison of passage curvature in vaneless diffusers A and B. (All dimensions in in.)

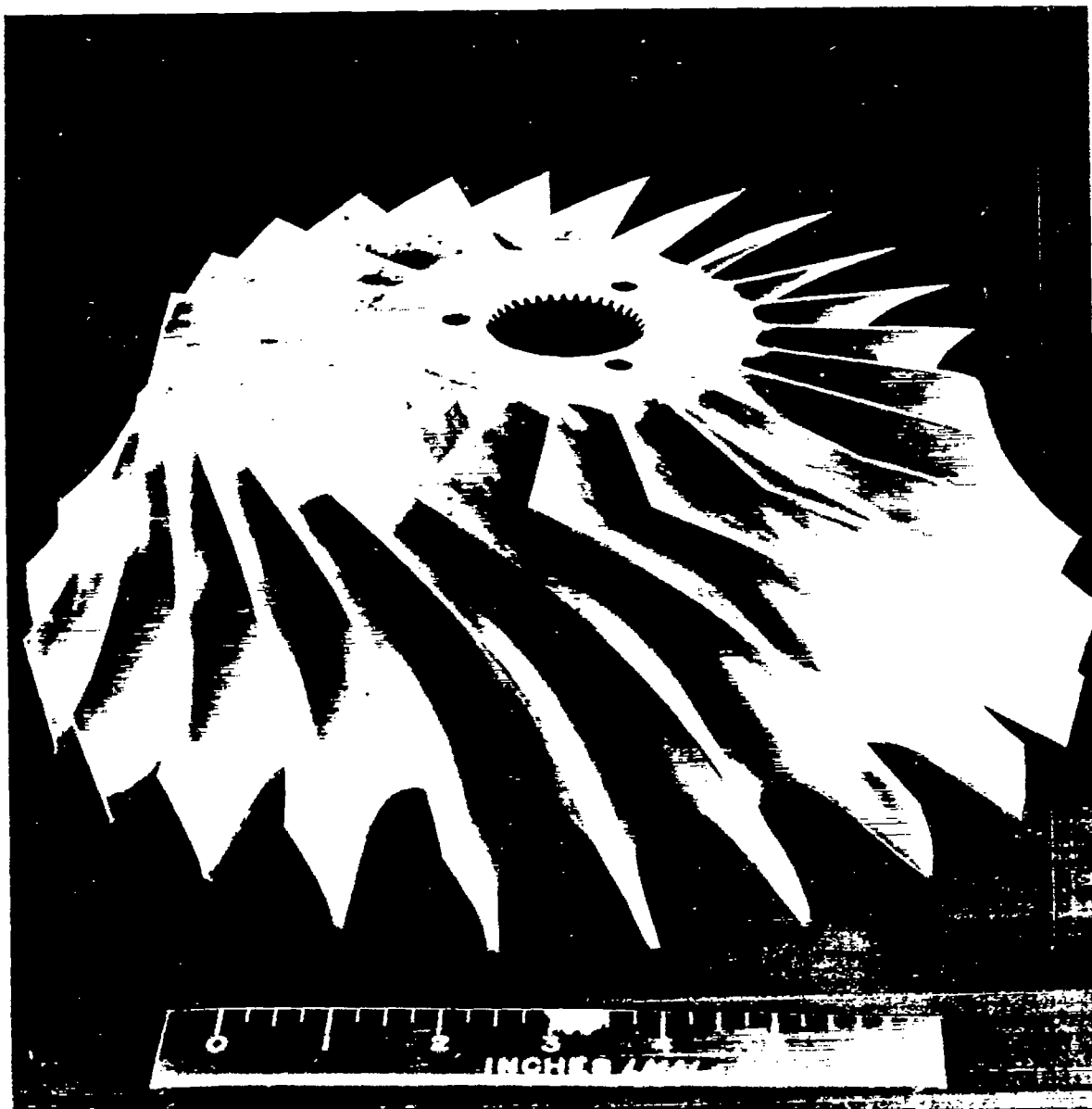

Figure 2. - Mixed-flow impeller B.

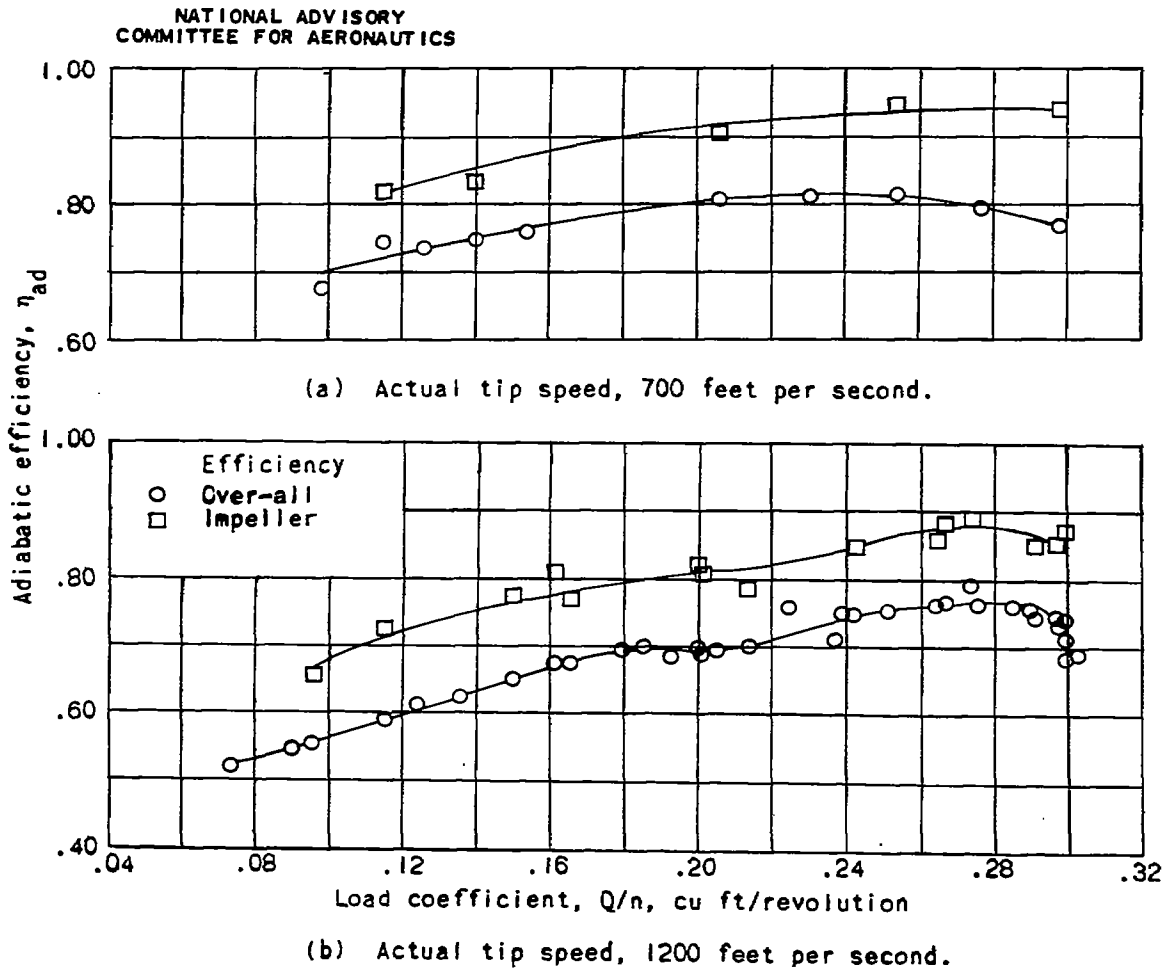

Figure 3. - Performance characteristics of compressor A.

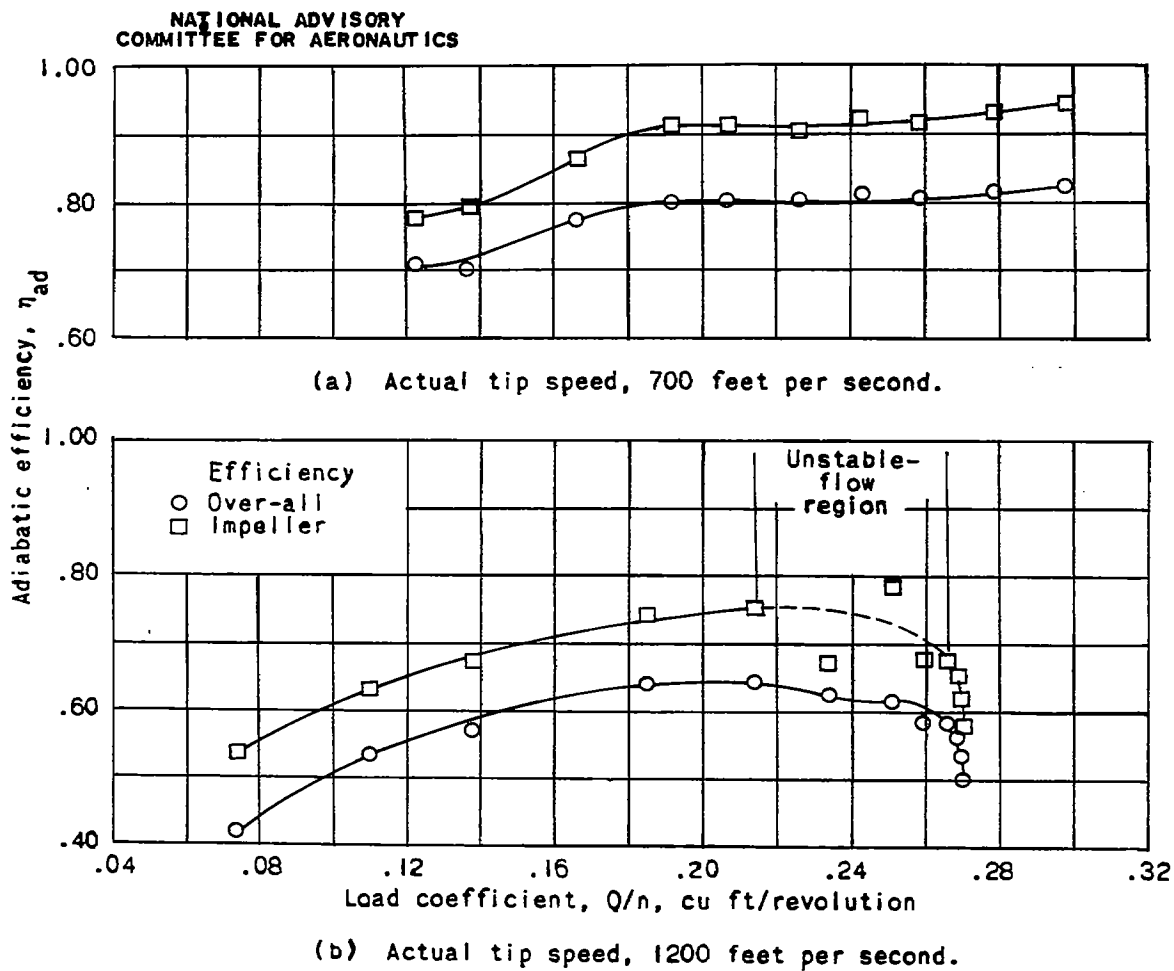

Figure 4. - Performance characteristics of compressor B.

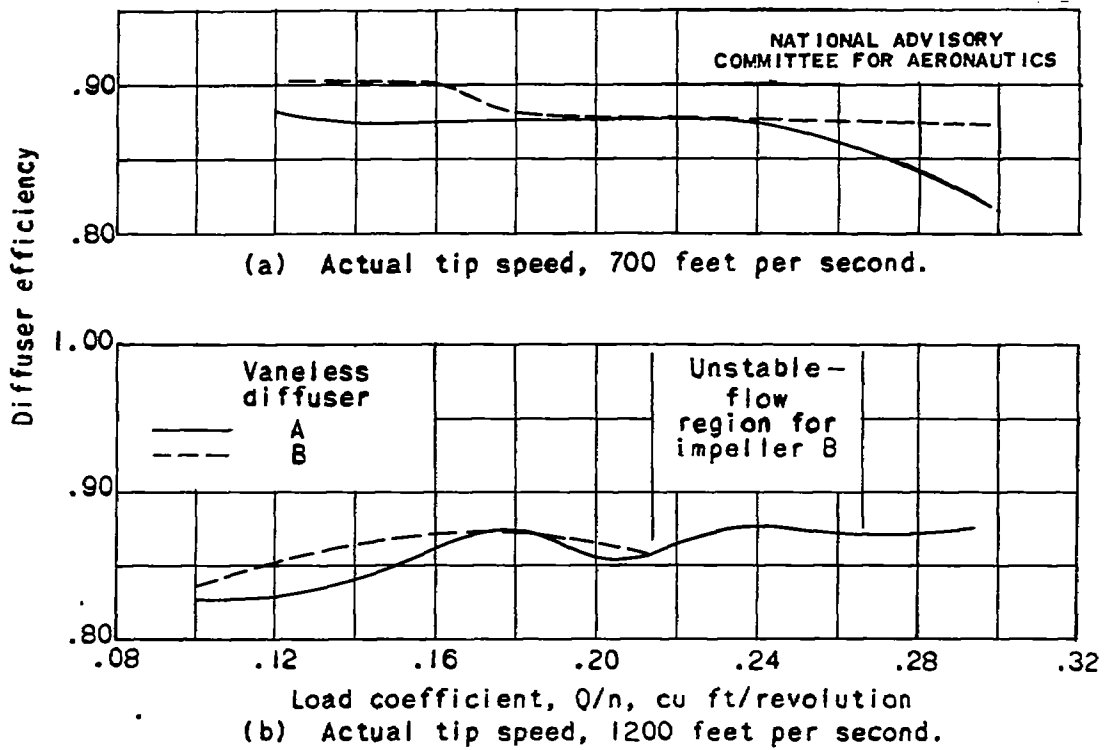

Figure 5. - Comparison of efficiencies of vaneless diffusers A and B.

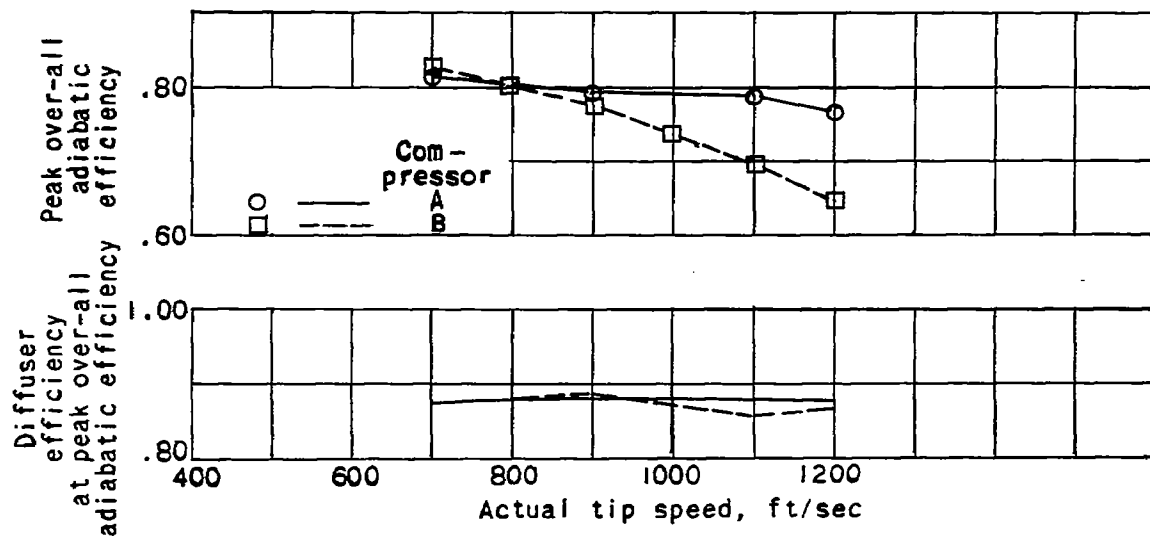

Figure 6. - Comparison of diffuser efficiencies with peak over-all efficiencies for compressors A and B.