

170

NATIONAL ADVISORY COMMITTEE FOR AERONAUTICS

TECHNICAL NOTE

No. 1178

APR 18 1947

A FLIGHT INVESTIGATION OF THE THERMAL
PERFORMANCE OF AN AIR-HEATED PROPELLER

By John F. Darsow and James Selna

Ames Aeronautical Laboratory
Moffett Field, California

FOR REFERENCE

NOT TO BE TAKEN FROM THIS ROOM



Washington
April 1947

NACA LIBRARY
LANGLEY MEMORIAL AERONAUTICAL
LABORATORY
Langley Field, Va.

NATIONAL ADVISORY COMMITTEE FOR AERONAUTICS

TECHNICAL NOTE No. 1178

A FLIGHT INVESTIGATION OF THE THERMAL
PERFORMANCE OF AN AIR-HEATED PROPELLER

By John F. Darsow and James Selna

SUMMARY

The thermal performance of an air-heated propeller, installed on a test airplane, was evaluated by observations of the ice-prevention properties of the propeller during flight in natural-icing conditions and by the collection of thermal data on the propeller during flight in clear air and in clouds at temperatures above freezing. The test propeller was equipped with hollow steel blades of a standard design which were altered to permit heated air to enter the blade cavities at the propeller hub and to leave the cavities at the blade tips. No provisions were made to control the distribution of air flow inside the blades.

The observations in natural-icing conditions together with the thermal test data indicate that little or no protection to the leading-edge region of the propeller blades would result during flight in severe natural-icing conditions. The observations in natural-icing conditions were limited in that only light-icing conditions were encountered; however, in these light-icing conditions ice accretions formed on the leading edges of the blades in the region of blade stations 30 to 40. The clear air and cloud tests showed the propeller blades to be inefficient heat exchangers in that more heat energy was discharged in the air flow leaving the propeller than was dissipated through the propeller-blade surfaces. The measured blade-surface temperatures indicated that inadequate heating was provided to the leading-edge region of the propeller and show the need of providing means to increase the heat flow through the leading-edge region of the blades.

INTRODUCTION

During the past few years, research has been directed to provide protection for aircraft propellers during flight in natural-icing conditions by the application of heat to the propeller blades. One

means of applying heat has been through the use of electrically heated, rubber blade shoes placed over the leading edges of the propeller blades (reference 1). These shoes, however, in their present state of development have some effect (although small) on the aerodynamic performance of the propeller, require frequent servicing, and require the availability of a suitable electrical power supply. In an attempt to provide a more simple system, and make use of the heat content of the airplane engine exhaust gases, one of the well known propeller manufacturers constructed an air-heated propeller. This propeller was equipped with hollow steel blades of a standard design. It had provisions for inducting heated air into the blade cavities at the propeller hub and of disposing of it through discharge nozzles located at the blade tips. No provisions were made for controlling the distribution of the heated air in the blade interiors.

The purpose of the present investigation was to evaluate the thermal performance of this air-heated propeller. The investigation consisted of flight tests in natural-icing conditions during which the ice-protection properties of the propeller were observed and flight tests in clear air and in clouds at temperatures above freezing during which thermal data on the propeller were obtained.

The investigation was conducted by the Ames Aeronautical Laboratory of the National Advisory Committee for Aeronautics. The flights in natural-icing conditions were conducted from the Army Air Forces Ice Research Base, Minneapolis, Minn., during the winter 1944-45; and the remainder of the tests were conducted at the Ames Aeronautical Laboratory, Moffett Field, Calif., in the summer of 1945.

DESCRIPTION OF EQUIPMENT

The test propeller, a four-blade, 14-foot-diameter, air-heated propeller was installed on the left engine of a test airplane. A similar installation, which was provided on the right engine for subsequent tests, is shown in figure 1. The operation of the propeller heating system is shown in figures 2 and 3. Ram air, heated by an exhaust-gas-air heat-exchanger installation (described in reference 2) was ducted to the stationary part of the propeller air manifold. The heated air was then transmitted to the rotating part of the propeller air manifold, admitted to the blade cavity through holes in the blade shanks, and discharged through nozzles located at the blade tips. The air particles in the blade are subject to radial accelerations, due to the rotation of the propeller, which results in a pumping action. This pumping action together with the ram pressure at the heat exchanger induced the air flow through the system. In order to reduce the air leakage between the

stationary and rotating parts of the propeller air manifold, and between the blade shanks and the rotating part of the propeller air manifold, carbon seals were provided as shown in figure 3. The approximate propeller-blade sections and a sketch of the propeller-tip discharge nozzles are given in figures 4 and 5, respectively. As employed herein, the term "station" denotes the radial distance from the center of rotation in inches. (See fig. 4.)

Instrumentation was provided to measure the ambient-air temperature the rate of air flow to the propeller, the temperature of the heated air entering and leaving the propeller, and various blade-surface temperatures. The location and designation of this instrumentation is given in figure 6. The thermocouples installed on the propeller blade surface were surface type thermocouples having a thickness of .001 inch. They were installed on the propeller blade between two coats of paint.

The instrumented propeller blade and the thermocouple leads at the blade shank are shown in figure 7. A mercury-in-glass thermometer located on the side of the airplane was used to check the ambient-air temperature indicated by the ambient-air thermocouple (TA_{S3}) shown in figure 6. The electrical circuit by means of which the temperature indications of the thermocouples located on the rotating part of the propeller installation were conveyed to the temperature recording equipment is shown diagrammatically in figure 8. The leads of these thermocouples were attached to a selector switch as shown in the circuit diagram of figure 8. The selector switch was located on the nose of the propeller spinner (fig. 6), and it was of special design and operated similar to a standard recording potentiometer stepping switch. Copper leads were used to extend the thermocouple circuit from the selector switch to the slip rings and from the slip rings to the recording potentiometer. The portable potentiometer was placed in the circuit to compensate for any potentials generated in the circuit other than those produced by the thermocouples, and it was employed as follows: (1) The selector switch shown in figure 8 was actuated to provide a reading of the ambient-air temperature TA_{S3} on the recording potentiometer and (2) the portable potentiometer was then adjusted to make this reading of TA_{S3} on the recording potentiometer equivalent to the temperature indicated by the mercury-in-glass thermometer located on the side of the airplane. Thus all potentials in the circuit, other than the thermocouple potential, were nullified and all the thermocouples located on the rotating part of the propeller installation could be recorded by permitting the recording potentiometer to actuate the selector switch.

The thermocouple installations on the rotating portion of the propeller assembly were not available for the natural-icing flights. In the case of these flights, therefore, the instrumentation provided only data on the quantity and temperature of heated air supplied to the propeller.

A standard airplane tachometer and sensitive altimeter were employed to measure the engine speed and test altitude, respectively.

TESTS

For the flights in natural-icing conditions, the airplane was operated at the cruise conditions of 950 to 1000 propeller rpm (1900 to 2000 engine rpm) and indicated airspeeds of 150 to 160 miles per hour. During these tests measurements were made of the temperature and the rate of air flow delivered to the propeller. At all times the flow rate to the propeller was the maximum obtainable for the operating conditions. Visual and photographic observations were made of the ice-protection qualities of the propeller.

At the close of the period during which natural-icing conditions prevailed, the instrumentation on the rotating part of the propeller installation was installed and flight tests were undertaken in clear air and in clouds above freezing to obtain thermal data on the propeller. The tests were conducted at 2700 to 3900 feet pressure altitude, 160 miles per hour indicated airspeed, 950 propeller rpm, with a maximum rate of air flow to the propeller. These test conditions were established as being comparable to the operating conditions during the icing flights.

Measurements of the instrumented blade surface and tip air temperatures, as well as measurements of the heated-air-flow rates and the temperature of the air entering the propeller were recorded for these tests. One test run was made with the heated-air supply duct disconnected from the heat exchanger, and the propeller pumping free-stream air, in order to obtain an indication of the propeller-blade surface-temperature rises caused by adiabatic and friction heating resulting from the external and internal air flows.

RESULTS AND DISCUSSION

The observations made during flight in natural-icing conditions are presented in table I. These observations were limited in that only light-icing conditions were encountered. Light-icing conditions are defined as those in which an unprotected airplane could sustain flight almost indefinitely. These results show, however, that even in these light-icing conditions, ice accumulated on the leading edge of the propeller blades in the region of stations 30 to 40 as shown in figure 9. No ice formation on the blades aft of the leading-edge regions was observed during the tests.

The results of the thermal tests conducted in clear air and clouds (above 32° F) are presented in tables II and III. The ambient-air temperatures and the propeller-tip air temperatures given in tests 3, 4, 5, and 7 of table II have been corrected for the effects of kinetic heating by the relationship

$$T = T_i - \frac{K V^2}{2g J c_p} \quad (1)$$

where

- T corrected air temperature, °F
 T_i indicated air temperature, °F
 V velocity of air, feet per second
 g acceleration due to gravity, feet per second, second
 J mechanical equivalent of heat, 778 foot-pounds per Btu
 c_p specific heat of air at constant pressure, Btu per pound, °F
 K percentage of full adiabatic heating

The values of propeller-tip air temperature TAS₂ given for the test conducted with unheated-air flow to the propeller (test No. 6) has not been corrected for the effects of kinetic heating since no air-flow-rate data were obtained for this test. In correcting the ambient-air temperature for the cloud test (test No. 7) the value of specific heat for wet air (reference 3) under the test conditions was employed. In correcting the propeller-tip air temperature TAS₂, an average velocity in the blade cavity at the station where TAS₂ was located was employed. The value of K for all calculations was taken as 0.9, this value having been previously established for the mercury-in-glass thermometer on the side of the airplane and considered applicable to the stagnation-type-air thermocouples used to measure temperatures TAS₂ and TAS₃.

The value of air-flow rate given in table III is an average value of several measurements at the test conditions. The individual values did not differ from the value presented by more than ± 50 pounds per hour. The actual air-flow rate through each propeller blade probably differs from the values presented due to cold air leakage into the heated airflow at the carbon seals, (fig. 3). This leakage, however, is presumed to be small.

The heat exchange efficiency of the instrumented blade has been approximated in table III. The values calculated are based on the temperature of the air entering the propeller manifold since no measurement was made of the temperature of the air entering the blade cavity. The calculations also neglected consideration of the kinetic energy imparted by the propeller to the internal airflow which converts to heat. The values calculated, however, are considered sufficiently accurate to show that the propeller blade was an inefficient heat exchanger. These calculations indicate that less than half of the heat content of the air delivered to the propeller was removed by the propeller.

It is noted in table II that the propeller-tip air temperature for the test conducted with unheated-air flow to the propeller (test No. 6) is indicated to be 40° F higher than the temperature measured in the propeller manifold. As previously mentioned, the tip air temperature for this test has not been corrected for the effects of kinetic heating, and also, the kinetic energy which goes into heat in the internal flow is of unknown magnitude.

The blade-surface temperatures of table II have been plotted as temperature distributions in figure 10. The temperature distribution (above ambient-air temperature) obtained during the dry-air tests with heated-air flow to the propeller is shown in figure 10(a). The scatter of the data for the several tests plotted is accountable to slightly different test conditions and to inaccuracies of measurement. The temperature rises above ambient-air temperature given in this figure are only partially a result of the heat dissipated through the propeller-blade surfaces, the balance being due to external kinetic heating of the propeller blade. In figure 10(b), the mean curve of figure 10(a) is compared with the data obtained during the dry-air test with (free-stream) unheated-air flow to the propeller. The temperature rises for the unheated airflow are approximately those due to external kinetic heating of the blade. The curve drawn through the leading edge points was calculated by the relationship

$$\Delta T = \frac{v^2}{2g J c_p} \quad (2)$$

where ΔT is the theoretical temperature rise due to external kinetic heating. The temperature difference between these two curves may be attributed to the heat dissipated through the propeller-blade surfaces. It is indicated by figure 10(b) that the temperature rise of the blade leading edges due to the heated-air flow varies approximately from 60° F at station 15 to 10° F at and beyond station 40. The chordwise temperature rise at station 36 due to heated-air flow is shown in this figure to vary from 15° F at the leading edge to about 50° F at 50 percent chord.

The higher leading-edge temperatures at the stations nearer the propeller hub are probably a result of (1) the conduction of heat along the blade from the propeller manifold, (2) a reduction in heat transfer due to the low velocity field ahead of the engine cowling and, (3) higher temperatures of the internal airflow near the hub.

The chordwise temperature distribution is probably due to three factors: (1) the concentration of the heated-air flow along the trailing edges of the blade cavity caused by the Coriolis forces, (2) the existence of the largest external heat-transfer coefficients at the blade leading edge, and (3) the fact that the blade material is thickest (lowest thermal conductivity) at the leading edge. The results show the necessity of providing means to increase the heat flow to the leading-edge region of the blades. This could be accomplished by the addition of a radial baffle within the blade to restrict the heated-air flow to the leading-edge region of the blade cavity. A second, but more major modification, would be to reduce the material thickness at the leading edge of the blade.

In figure 10(c) the mean curve of figure 10(a) is compared with the data obtained during flight in clouds. In this plot, the cloud data have been plotted as actual temperatures and the curve of figure 10(a) has been placed with respect to the ambient-air temperature of the cloud test. This method of plotting was used because the factors of wet-air kinetic heating of the blade surfaces and evaporization of water from the blade surfaces are dependent on the actual surface temperatures of the blade. A detailed discussion of these factors is presented for a wing surface in reference 4. The data obtained in the clouds provided no temperature data beyond blade station 57. Also included in this figure is a plot of the theoretical leading edge temperatures due to kinetic heating based on equation 2 using wet air values of c_p . This figure shows that the temperature rise of the blade due to air heating diminished to practically zero at station 57. The leading edge temperature rises above ambient air temperature shown in this figure are very low (less than 10° F from station 35 to 57). This accounts for the fact that ice was observed to form on the leading edge regions of the propeller blades during flight in light natural icing conditions.

Application of the analysis of reference 4 to the present tests indicates that the blade-surface temperature rises above ambient-air temperature during the flights in light-icing conditions were probably greater than those experienced during the flight in clouds because the lower ambient temperature in the former tests would result in increased kinetic heating (lower c_p) and a reduction in evaporative cooling.

The test data indicate that the temperature rise of the leading edges of the propeller blades could be expected to provide only limited ice prevention in light-natural-icing conditions and therefore it may be

concluded that little or no protection would be provided to the leading-edge regions of the blades in severe icing conditions.

CONCLUSIONS

The results of the thermal performance tests of an air-heated propeller indicate the following:

1. The air-heated-propeller installation tested would offer little or no protection to the leading-edge regions of the propeller during flight in severe natural-icing conditions.

2. The surface-temperature distribution is undesirable, and means should be provided to concentrate the heat in the leading-edge regions of the blades.

Ames Aeronautical Laboratory,
National Advisory Committee for Aeronautics,
Moffett Field, Calif., Sept. 1946.

REFERENCES

1. Scherrer, Richard, and Rodert, Lewis A.: Tests of Thermal-Electric De-Icing Equipment for Propellers. NACA ARR No. 4A20, 1944.
2. Jones, Alun R., and Spies, Ray J., Jr.: An Investigation of a Thermal Ice-Prevention System for a C-46 Cargo Airplane. III - Description of Thermal Ice-Prevention Equipment for Wings, Empennage, and Windshield. NACA ARR No. 5A03b, 1945.
3. Hardy, J. K.: Kinetic Temperature of Wet Surfaces. A Method of Calculating the Amount of Alcohol Required to Prevent Ice and the Derivation of the Psychrometric Equation. NACA ARR No. 5G13, 1945.
4. Hardy, J. K.: An Analysis of the Dissipation of Heat in Conditions of Icing from a Section of the Wing of the C-46 Airplane. NACA ARR No. 4I11a, 1944.

TABLE I.- OBSERVATIONS OF AIR-HEATED PROPELLER
DURING FLIGHT IN LIGHT-ICING CONDITIONS

(1)	Test number	1	2
(2)	Pressure altitude (ft)	4000	4000
(3)	Ambient-air temperature (°F)	13.5	17
(4)	Propeller speed (rpm)	950	1000
(5)	Indicated airspeed (mph)	160	160
(6)	Temperature of air entering propeller, T _{A1} (°F)	350	370
(7)	Air-flow rate per propeller blade (lb/hr)	350	350
(8)	Heat supplied per blade (Btu/hr) (0.24)(7)(6-3)	28,000	29,300
(9)	Remarks	Ice accumulated on leading edge of blades in region of blade stations 30 to 40.	Ice accumulated on leading edge of blades in region of blade stations 30 to 40.

TABLE II.- TEMPERATURE DATA OBTAINED DURING FLIGHT TESTS
OF AN AIR-HEATED PROPELLER IN CLEAR AIR AND CLOUDS

Test number		3	4	5	6	7
Test condition		Clear air, heated-air flow to propeller	Clear air, heated-air flow to propeller	Clear air, heated-air flow to propeller	Clear air, ambient-air flow to propeller	Clouds, heated-air flow to propeller
Pressure altitude (ft)		3600	3900	3000	3900	2700
¹ Ambient-air temperature, TAg3, (°F)		67	42	56	61	45
Propeller speed (rpm)		950	950	950	950	950
Indicated airspeed (mph)		160	160	160	160	160
Heated-air temperatures (°F)	TA1	350	360	360	66	330
	TAg2	252	222	229	106	217
Propeller surface temperatures (°F)	TS1	----	----	----	----	----
	TS2	116	92	99	84	----
	TS3	----	----	----	----	----
	TS4	106	79	82	85	54
	TS5	96	74	81	79	53
	TS6	93	66	75	78	61
	TS7	106	84	84	70	59
	TS8	122	91	97	78	67
	TS9	158	128	123	70	88
	TS10	116	112	102	71	78
	TS11	123	111	115	66	79
	TS12	108	89	95	72	67
	TS13	102	73	84	73	57
	TS14	87	72	72	74	64
	TS15	106	88	92	67	66
	TS16	112	96	96	67	75
	TS17	113	102	95	63	83

¹All values of TAg3 and values of TAg2 for tests 3, 4, 5, and 7 corrected for kinetic heating.

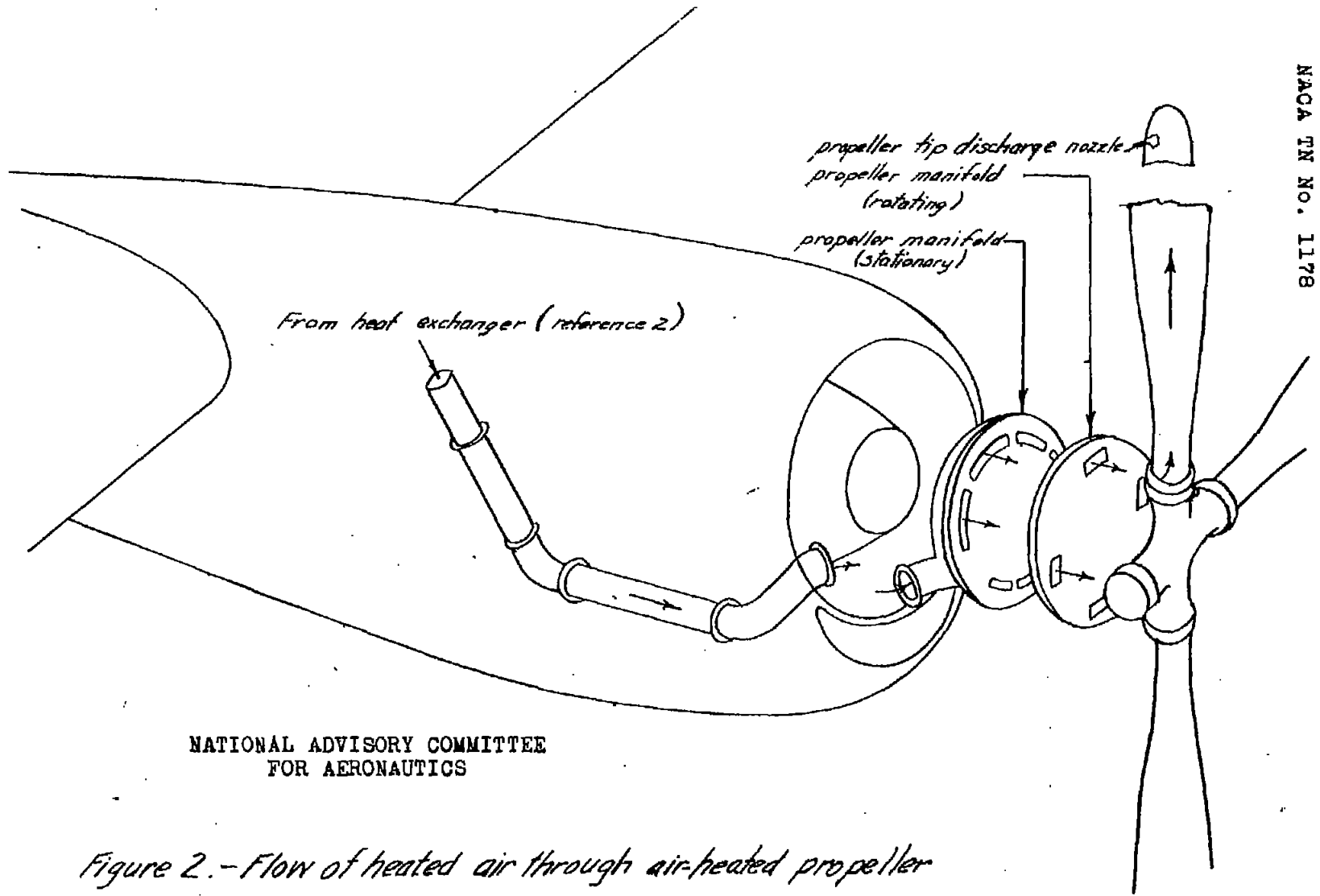
TABLE III.- HEATED-AIR-FLOW RATES AND HEAT-FLOW DATA
OBTAINED DURING FLIGHT TESTS OF AN AIR-HEATED
PROPELLER IN CLEAR AIR AND CLOUDS

(1)	Test number	3	4	5	6	7
(2)	Average air-flow rate per propeller blade (lb/hr)	350	350	350	--	350
(3)	¹ Temperature of air entering propeller (°F)	283	318	304	--	285
(4)	¹ Temperature of air discharged from blade (°F)	185	180	173	--	172
(5)	Heat supplied to blade (Btu/hr) (0.24)(2)(3)	23,700	26,700	25,500	--	24,000
(6)	Heat discharged at blade tip (Btu/hr) (0.24)(2)(4)	15,500	15,100	14,500	--	14,400
(7)	Heat released by air in blade (Btu/hr) (5)-(6)	8,200	11,600	11,000	--	9,600
(8)	Blade heat-exchange efficiency (percent) (7)/(5) × 100	35	39	43	--	40

¹Above ambient-air temperature.

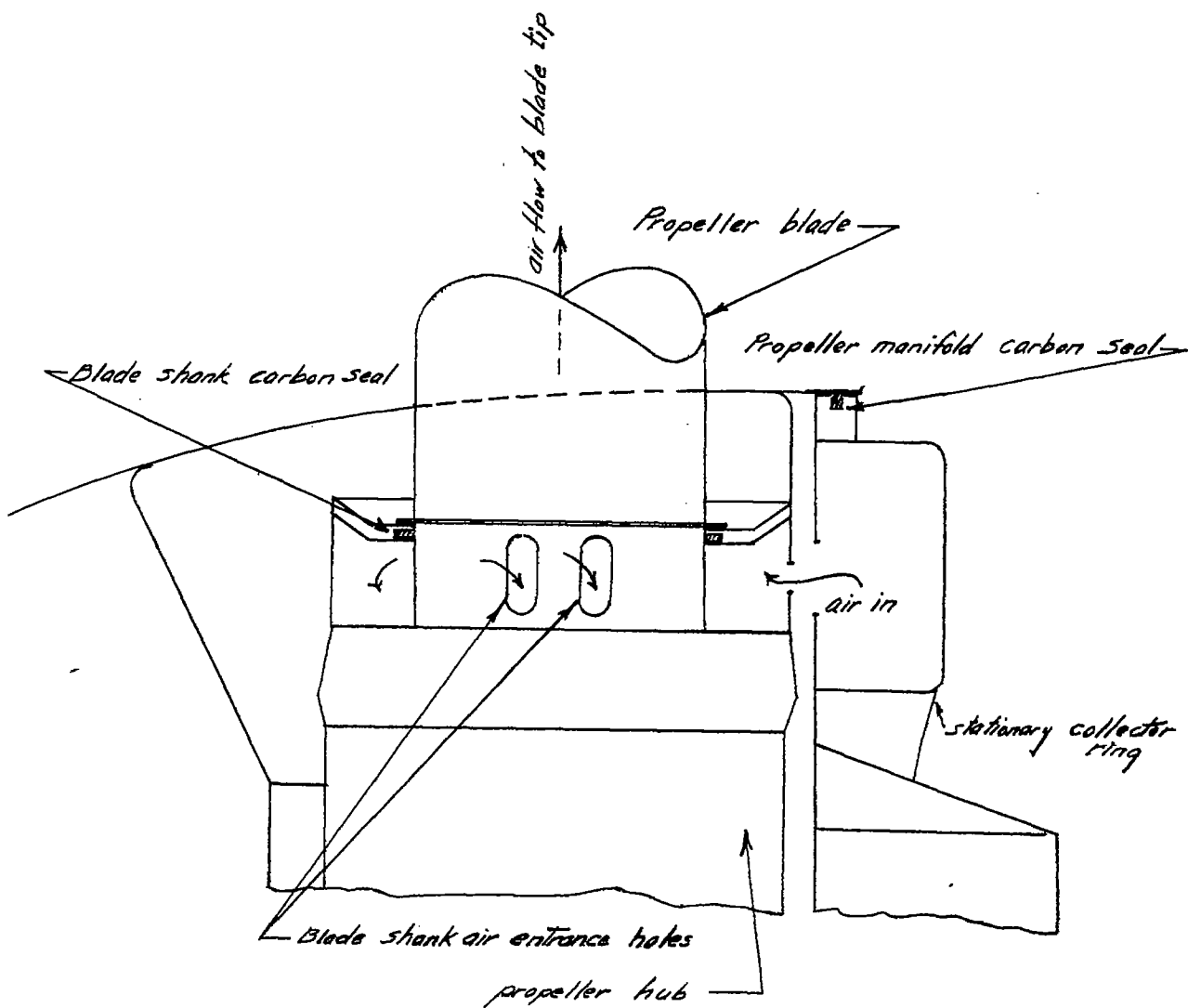


Figure 1.- Air-heated propeller installed on the right engine of the test airplane.



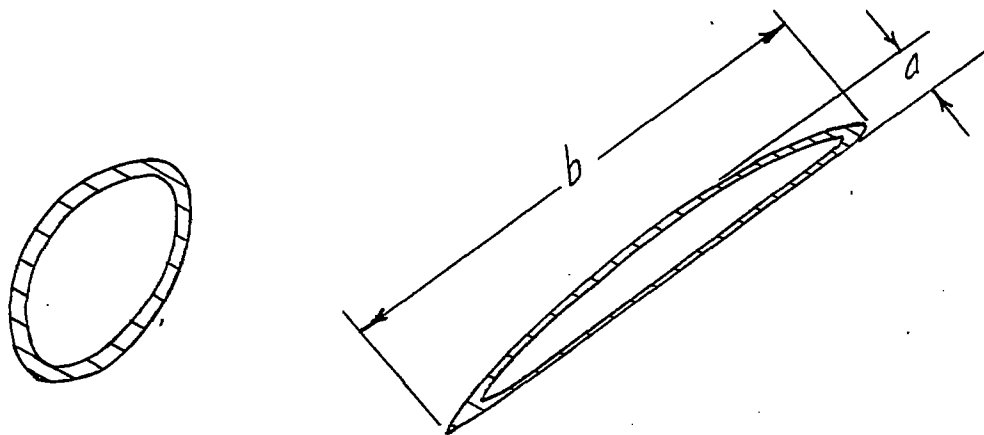
NATIONAL ADVISORY COMMITTEE
FOR AERONAUTICS

Figure 2.- Flow of heated air through air-heated propeller
installed on the test airplane



NATIONAL ADVISORY COMMITTEE
FOR AERONAUTICS

Figure 3.- Schematic diagram of air-heated propeller air manifold.



Station 15

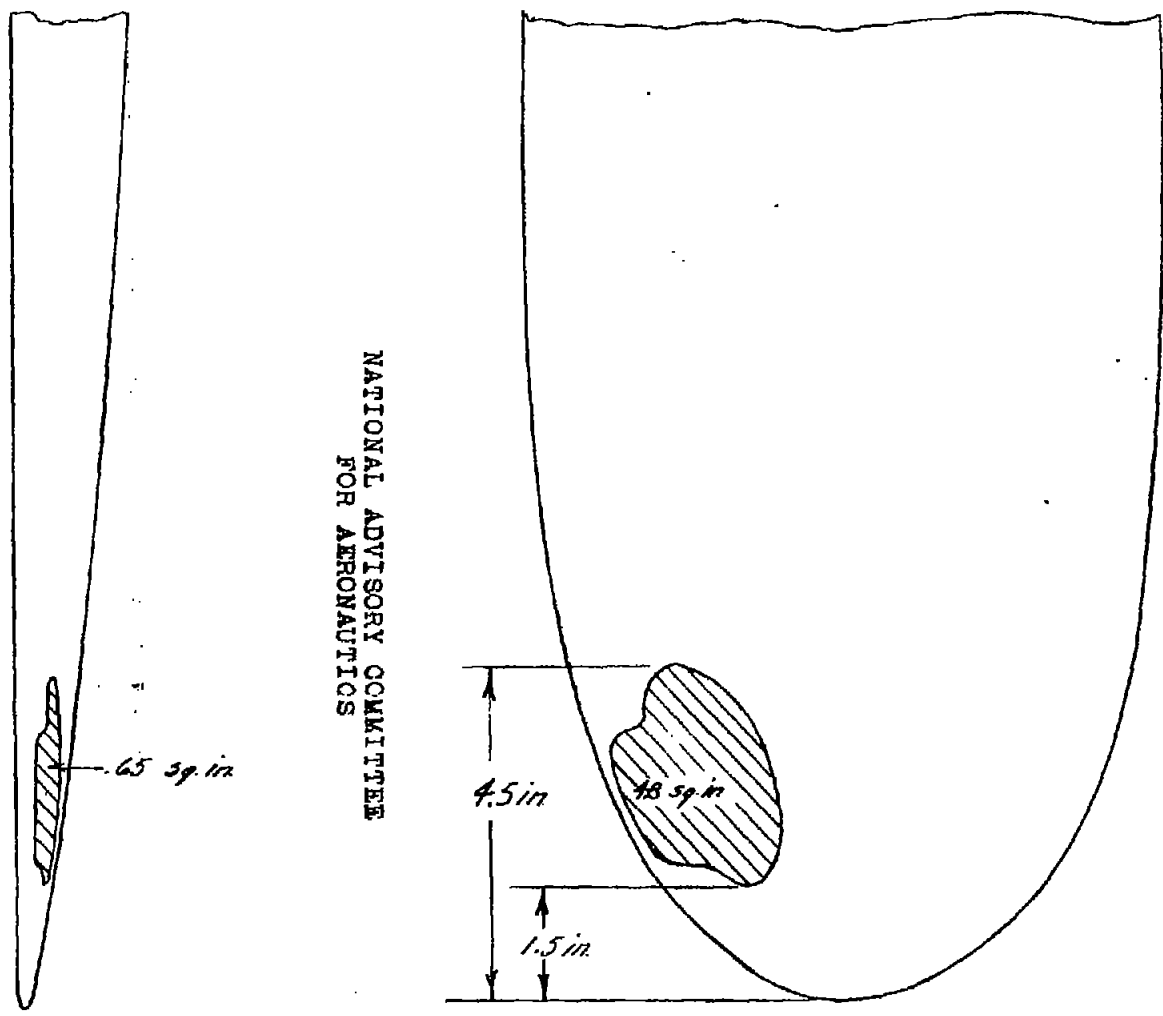
Typical Section

NATIONAL ADVISORY COMMITTEE
FOR AERONAUTICS

Sta'	"a" inches	"b" inches	Cavity Area sq. inches
15	3.368	5.94	10.95
33	1.279	11.62	7.85
39	1.121	12.13	7.39
45	1.017	12.12	6.59
57	0.840	11.26	5.08
69	0.678	9.75	3.49
75	0.585	8.63	2.43
81	0.390	7.14	1.75

'Measured from center of rotation, inches

Figure 4.- Air-heated propeller blade sections
at various blade stations.



NATIONAL ADVISORY COMMITTEE
FOR AERONAUTICS

Figure 5.- Sketch of air-heated propeller-tip discharge nozzle.

Legend
 TS - surface thermocouple
 TA - unshielded air thermocouple
 TA_s - stagnation type air thermocouple

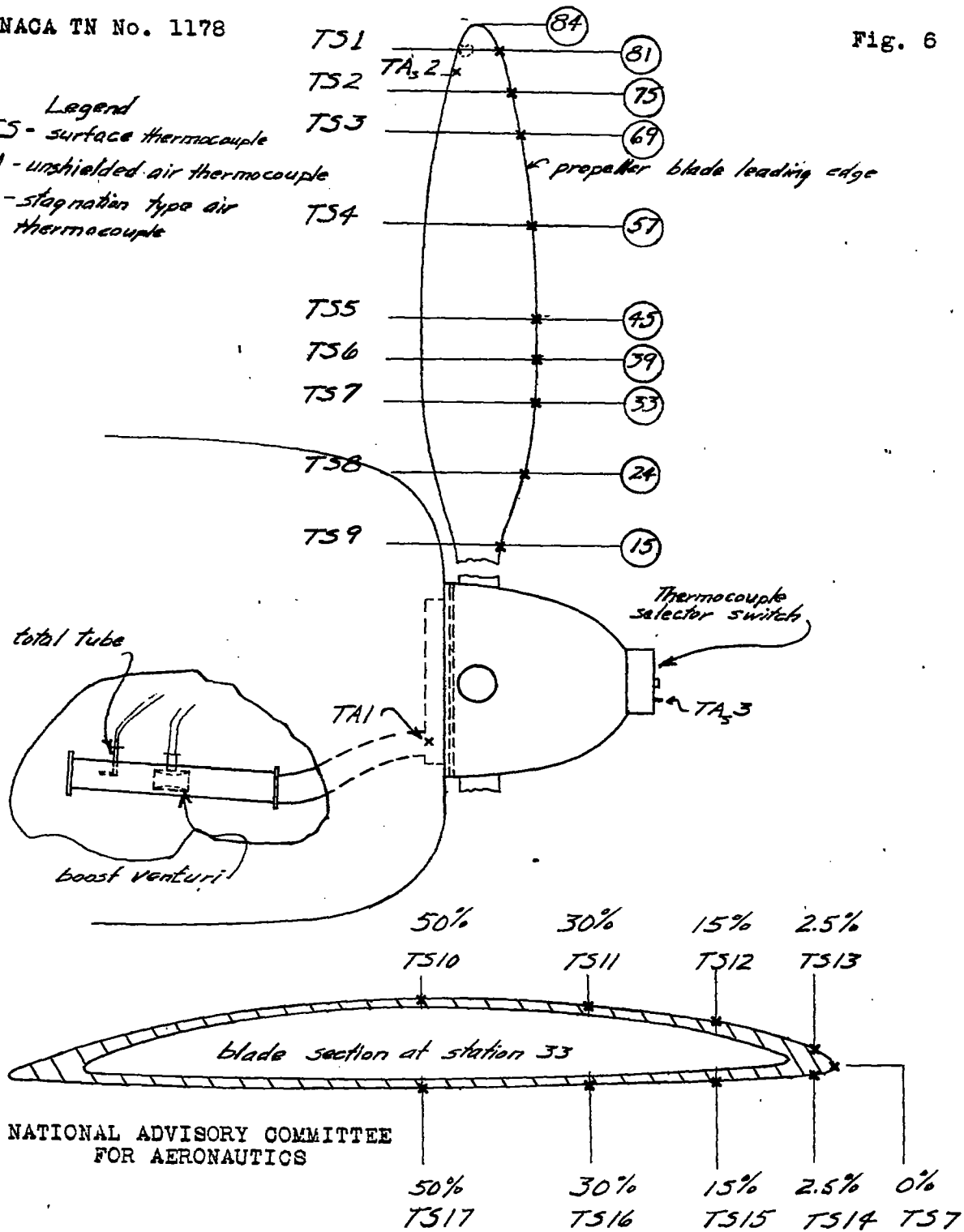
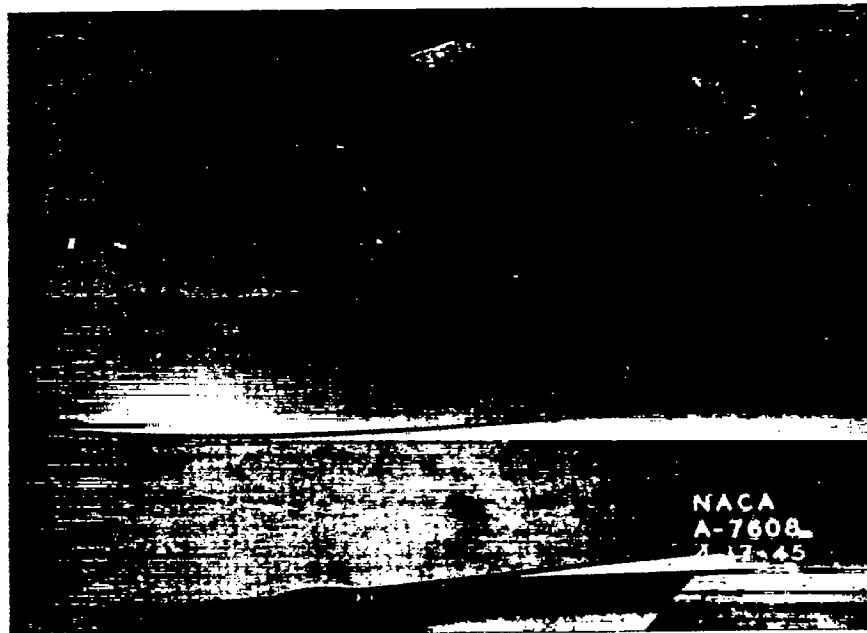
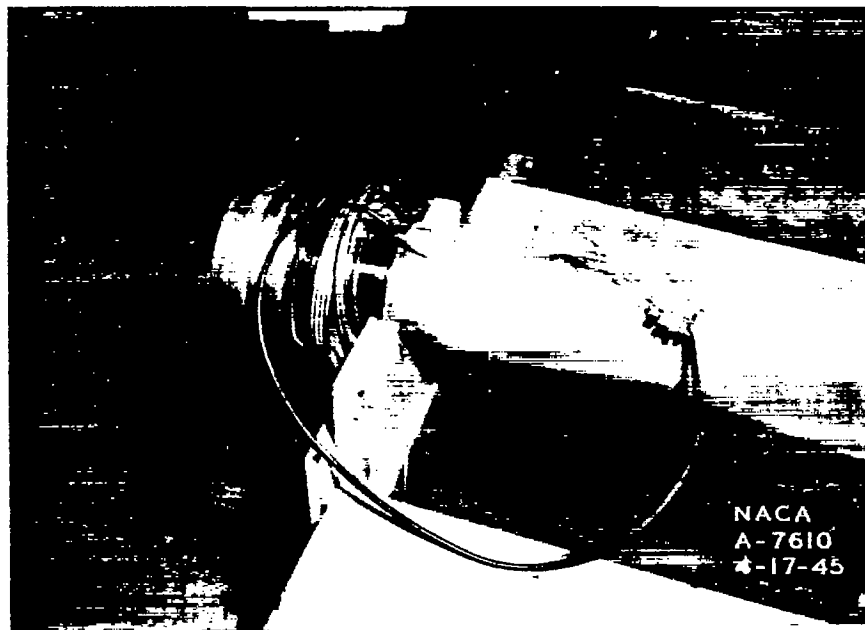


Figure 6.- Instrumentation of air-heated propeller for thermal performance tests.



(a) Instrumented blade.



(b) Thermocouple leads at blade shank.

Figure 7.- View of air-heated propeller blade after instrumentation.

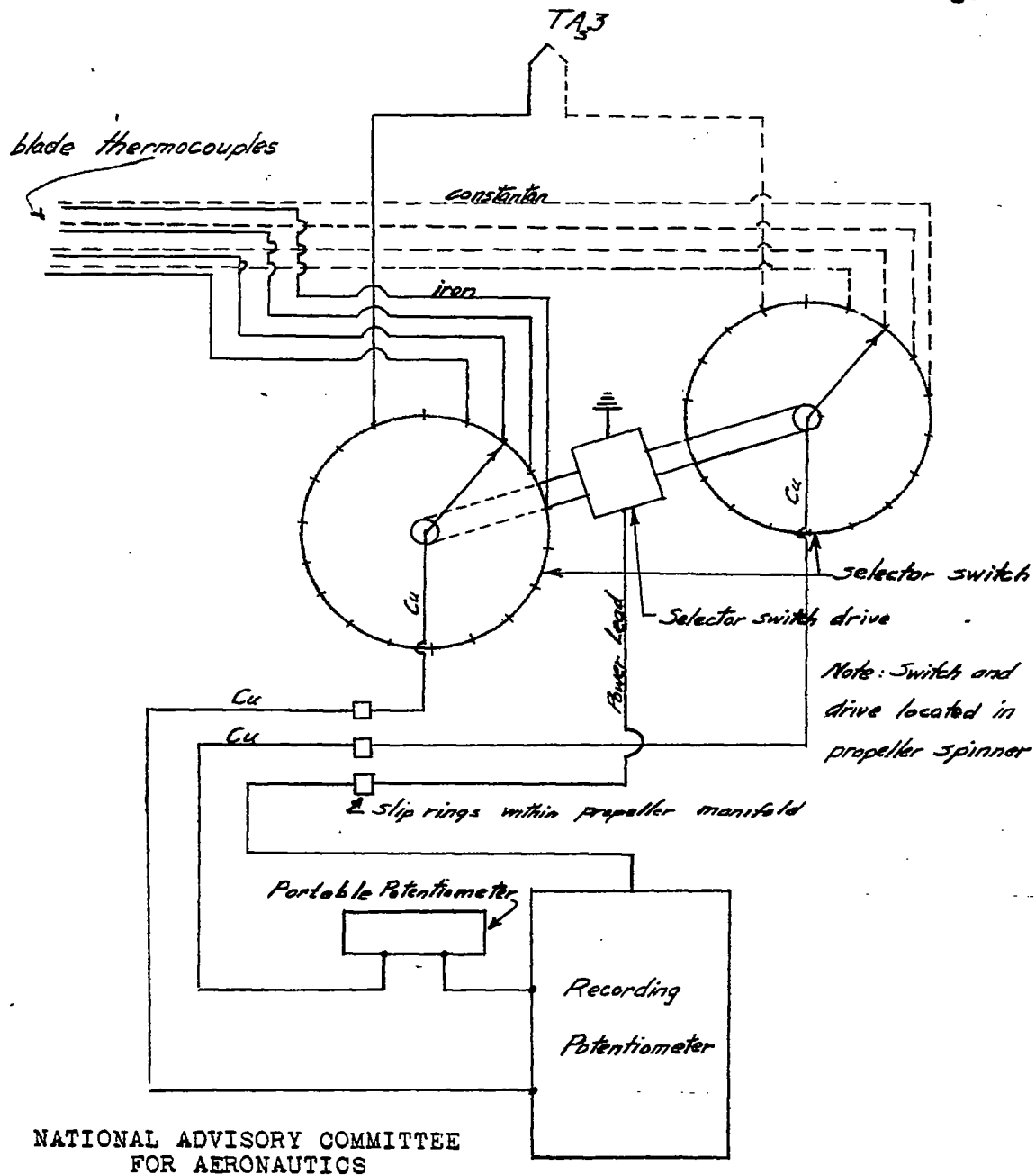


Figure 8:- Thermocouple circuit employed for measuring temperatures on the rotating part of air-heated propeller installation on the test airplane

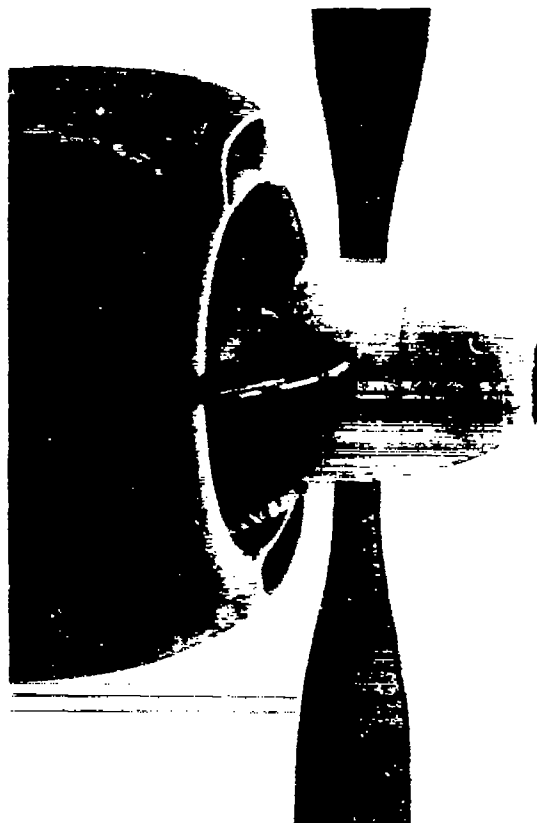
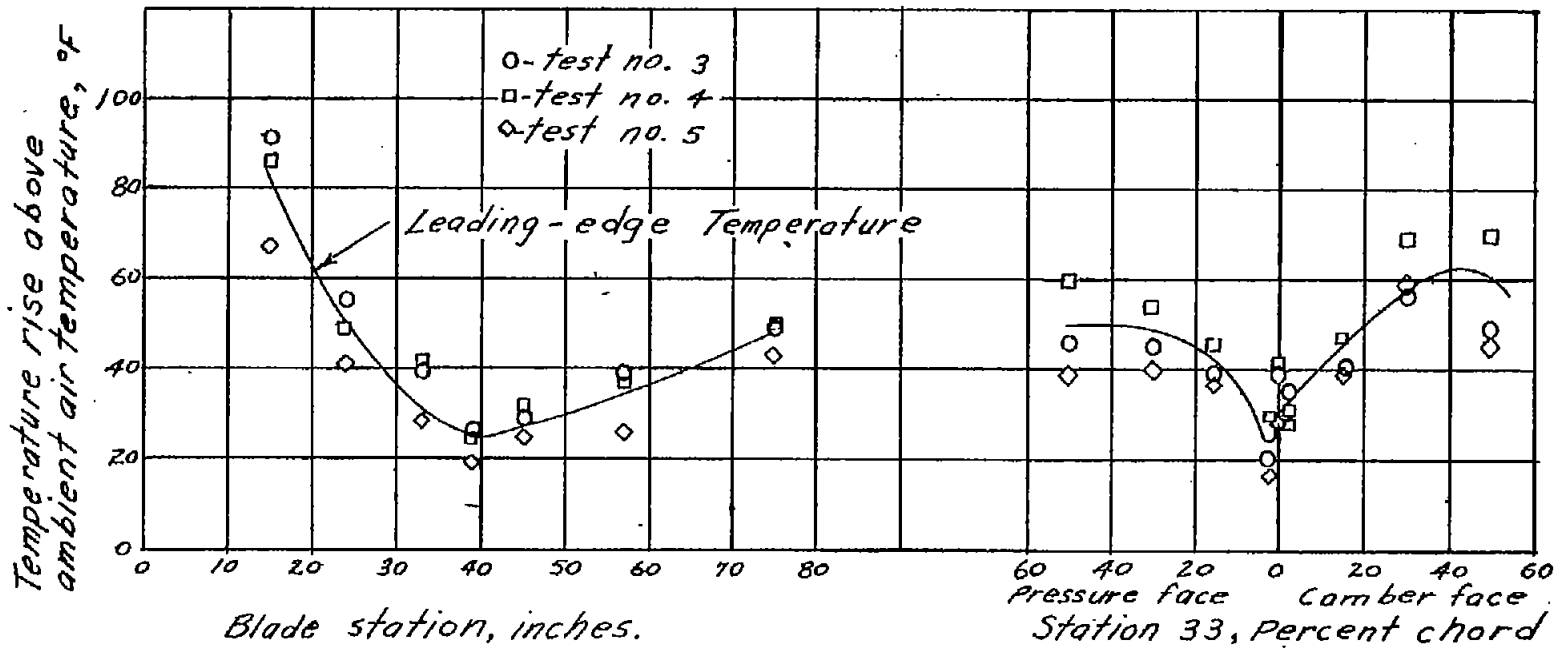


Figure 9.- Ice accretion on leading edge of air-heated propeller after flight in light-icing conditions.

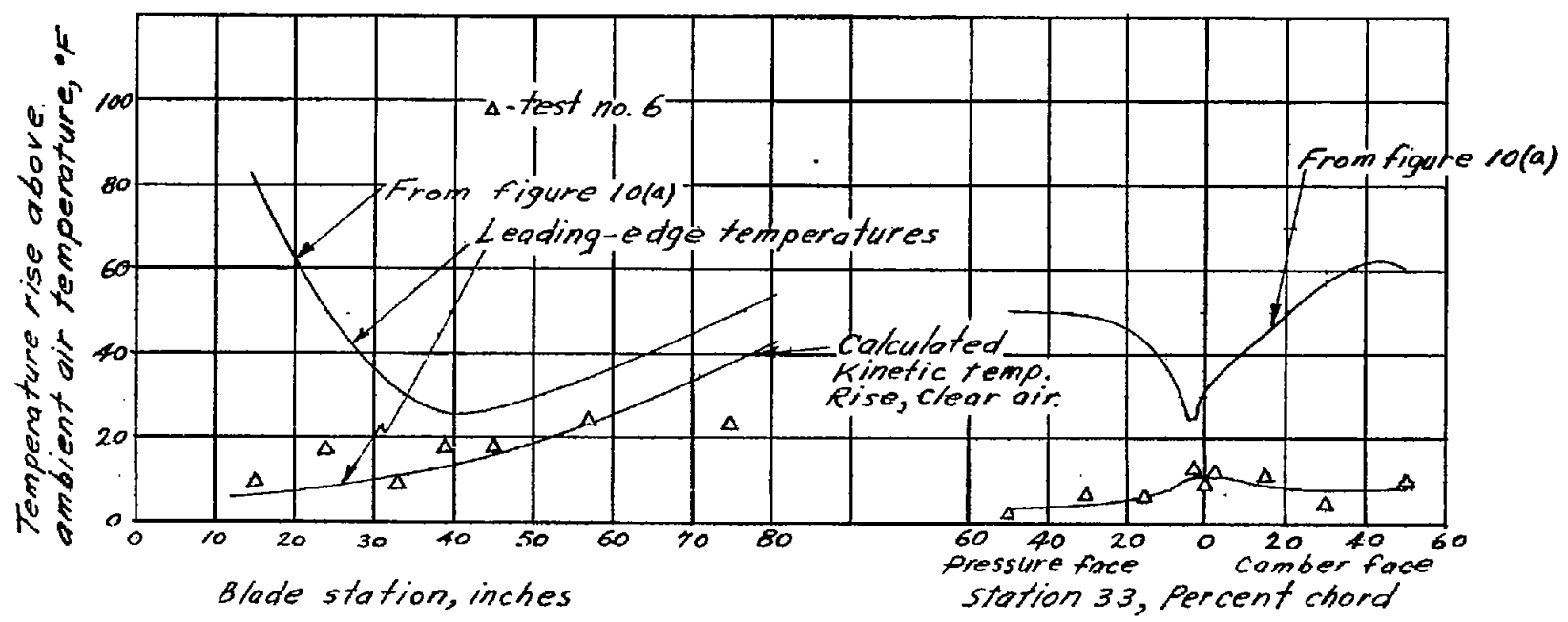
NATIONAL ADVISORY COMMITTEE
FOR AERONAUTICS



(a) Clear air, heated airflow to propeller

Figure 10.- Air-heated propeller surface temperature distribution obtained during flight in clear-air and cloud-test conditions.

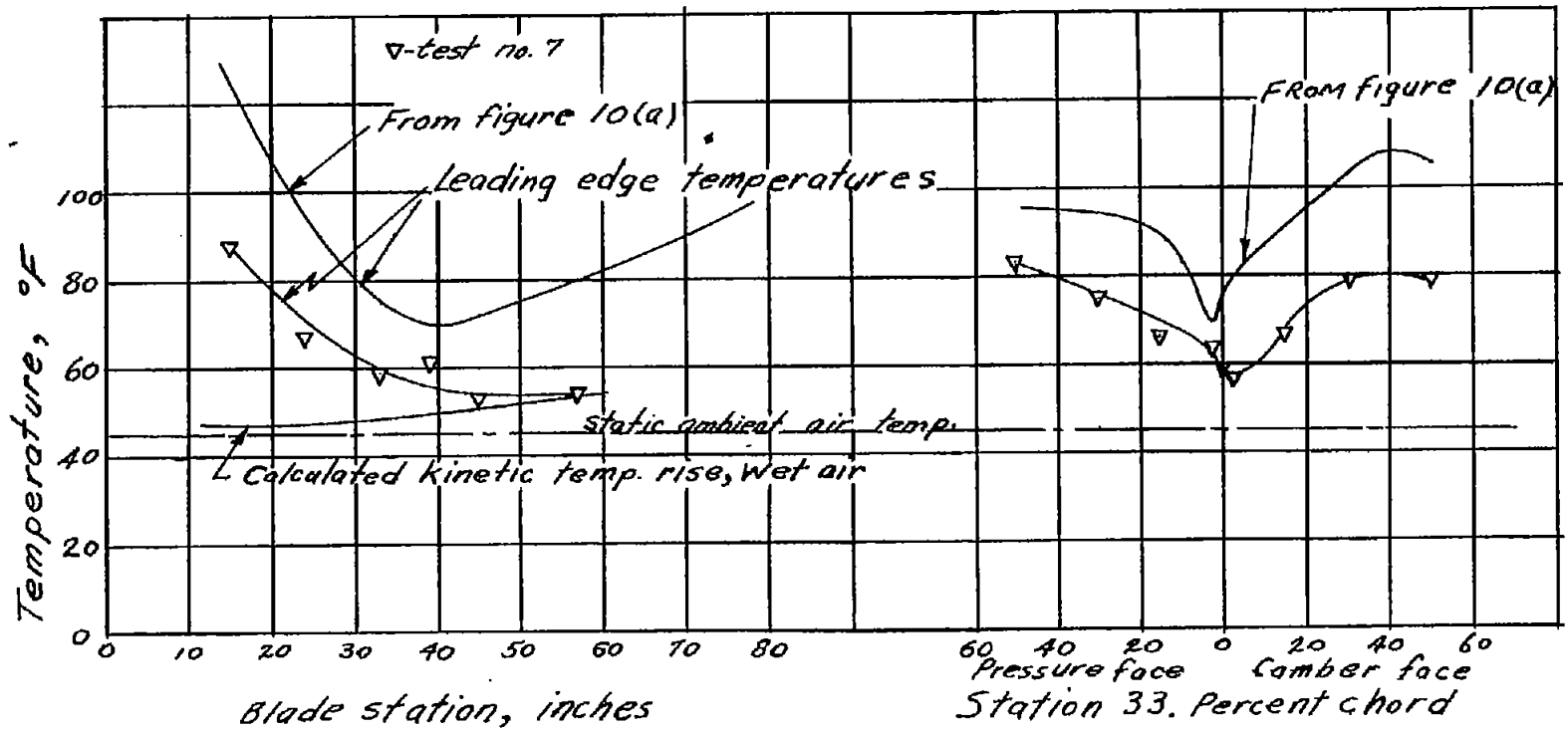
NATIONAL ADVISORY COMMITTEE
FOR AERONAUTICS



(b) Comparison of (a) with clear air, unheated air flow to propeller

Figure 10-Continued.

NATIONAL ADVISORY COMMITTEE
FOR AERONAUTICS



(c) Comparison of (a) with cloud test, heated air Flow to propeller

Figure 10.-Concluded.