

AUG 19 1946

~~5130~~
80

NATIONAL ADVISORY COMMITTEE FOR AERONAUTICS

TECHNICAL NOTE

No. 1108

LOAD CAPACITY OF ALUMINUM-ALLOY CRANKPIN BEARINGS AS
DETERMINED IN A CENTRIFUGAL BEARING TEST MACHINE

By E. Fred Macks and Milton C. Shaw

Aircraft Engine Research Laboratory
Cleveland, Ohio



Washington
August 1946

N A C A LIBRARY
LANGLEY MEMORIAL AERONAUTICAL
LABORATORY
Langley Field, Va.

NATIONAL ADVISORY COMMITTEE FOR AERONAUTICS

TECHNICAL NOTE NO. 1108

LOAD CAPACITY OF ALUMINUM-ALLOY CRANKPIN BEARINGS AS
DETERMINED IN A CENTRIFUGAL BEARING TEST MACHINE

By E. Fred Macks and Milton C. Shaw

SUMMARY

The load capacities of four aluminum-alloy radial-engine crankpin bearings were determined in a centrifugal bearing test machine. All the alloys had a load capacity in excess of 6000 pounds per square inch. The average load capacity for the best alloy of the group (0.93 percent Cu, 1.29 percent Fe, 1.14 percent Ni, 0.19 percent Si, 6.07 percent Sn, 90.38 percent Al) was greater than 9000 pounds per square inch. All the aluminum-alloy bearings were found to seize more suddenly and severely than comparable copper-lead or silver-lead-indium bearings.

Chemical analysis made after the bearings had been tested to failure showed that the actual composition of each aluminum alloy was different from the chemical specifications. In particular, the iron content was found to be in excess of that required by the nominal specifications. Inasmuch as the iron content is reported to influence the antiscoring properties of aluminum alloys, due consideration should be made of the actual composition rather than the nominal specifications in evaluating the aluminum alloys tested.

The physical characteristics of the bond between the aluminum alloy and steel back must be improved before the aluminum alloys can be used for radial-aircraft-engine master-rod bearings.

INTRODUCTION

As aircraft engines of high output are developed, bearing materials having greater load-carrying capacity and improved operating characteristics are required. Aluminum-alloy crankshaft bearings have been used or considered for a number of years. As early as 1911 (reference 1) bearings of 92 percent aluminum and 8 percent copper

were tested on a French railroad and performed satisfactorily, showing no measurable wear after 50,000 miles of service. These results were not confirmed, however, in subsequent tests of similar application.

Inasmuch as aluminum alloys are harder than other common bearing metals, it is necessary that the rubbing surfaces be more carefully machined to produce an excellent surface finish and that a very hard journal be used. Aluminum-alloy bearings are also reported to be sensitive to edge pressure produced by misalignment or deflection and should be used only when a complete oil film can be maintained. The high coefficients of expansion of aluminum alloys necessitate a diametrical clearance somewhat larger than that required by other common bearing materials and limit the operating temperature of the bearing. (See references 2 and 3.) The composition and properties of a number of aluminum-alloy bearings are given in table I.

This paper reports the results of tests to obtain the load-carrying capacity of four aluminum-alloy radial-engine crankpin bearings as determined in a centrifugal bearing test machine. The tests were conducted at the NACA Cleveland laboratory during the autumn of 1944.

APPARATUS

Bearing test machine. - The bearing test machine and accessory test equipment (fig. 1) used in this investigation were initially designed by the Pratt & Whitney Aircraft Division of the United Aircraft Corporation (reference 4) and later modified by the Wright Aeronautical Corporation. The principle of operation of this bearing test machine is shown in figure 2.

The test bearing is mounted in a cylindrical steel disk that produces a centrifugal force on the crankpin. This force varies as the square of the crankshaft speed. Uniform relative motion between the test bearing and the crankpin is produced by a gear train. The normally stationary gear is kept from rotating by means of a torque-measuring arm, which was designed to indicate the relative friction force developed by different test bearings. A friction clutch is introduced between the normally stationary gear and the torque arm to stop the relative motion between the crankpin and the test bearing when the friction torque exceeds a given value. This device prevents the test surfaces from being completely destroyed by seizure and permits a post-test examination to be made.

A combination overload relay and electrodynamic brake is used to bring the apparatus to rest within a few seconds after a predetermined value of power input to the motor has been exceeded. This device permits the same set of clutch plates to be used for more than one test and also automatically stops the apparatus quickly if failure of a part, other than the test bearing, occurs or if the clutch fails to slip when the test bearing seizes.

Oil system. - The oil system is shown diagrammatically in figure 3. Oil is pumped from the oil-weighing tank through a full-flow filter and rotameter to the test bearing. The oil-inlet pressure is maintained constant by means of an adjustable pressure-relief valve, which bypasses excess oil delivered by the pressure pump back into the oil-weighing tank. The oil leaving the test bearing is drawn from the sump of the bearing test machine by means of a scavenge pump. All the oil passes through the heater (which may or may not be used, depending upon the test conditions); a part of the oil passes through the cooler and is blended either automatically or manually with the oil that bypasses the cooler. By means of a pressure-relief valve, part of the blended oil is delivered at constant pressure through a full-flow filter to the idler-gear bearing and the rest is conducted to the hopper above the oil-weighing tank.

When a flow reading is taken, the solenoid valve connecting the hopper and the oil-weighing tank is closed. The mass rate of oil flow to the test bearing is determined from two successive readings of a manometer that indicates the head of oil above a self-balancing diaphragm located at the bottom of the oil-weighing tank (the details of this device are described in reference 5). The bypassed oil from the pressure pump enters the weighing tank below the solenoid valve; hence the manometer indicates only the oil flow to the test bearing. The rotameter is used to determine instantaneous rates of oil flow and the oil-weighing system gives a more accurate average rate of oil flow.

The test machine and the oil system are brought to operating temperature before the test is started by circulating oil from the oil-weighing tank through the heater and into the top of the bearing-test-machine housing. In this manner temperature equilibrium is attained in approximately 1 hour.

Comparison of operating characteristics of engine and bearing test machine. - A comparison of the load and speed characteristics of a radial-engine crankpin bearing in the centrifugal bearing test

machine with those for a similar bearing in the nine-cylinder radial engine is shown in figure 4, which is drawn with respect to the crank axis. Figure 4(a) and 4(c) show that the bearing rotates with constant angular velocity about the stationary crankpin and that the load is constant in magnitude and direction for a given crankshaft speed.

In the actual engine the bearing rotates with instantaneously varying angular velocity about the stationary crankpin (fig. 4(c)) and the load is seen to vary in both magnitude and direction at a given engine speed (fig. 4(b)). The locus of the end of the bearing-load vector for different values of crank angle is given by the oval path shown in figure 4(b). Because of the inherent symmetry of a nine-cylinder radial engine, the same oval path will be traced for successive 80° crank-angle intervals. The manner in which the crankpin bearing load varies with engine speed and indicated mean effective pressure for this engine is discussed in reference 6.

The center of the crankpin is translated along the crank axis to the corresponding point on the speed scale in order to determine the load vector at any value of crankshaft speed.

The load vector OA shown in figure 4(a) is for a speed of 2500 rpm and any value of crank angle. The load vector O'B shown in figure 4(b) is for an engine speed of 2500 rpm and an indicated mean effective pressure of 250 pounds per square inch at a crank-angle value of 0° . The 0° crank-angle position corresponds to the top-center position of the master connecting rod at the beginning of the expansion stroke.

The operating characteristics of the bearing test machine differ from those in the actual engine as follows:

| | Bearing test machine | Nine-cylinder radial engine |
|--|-------------------------|--|
| Relative motion between crankpin and bearing | Constant | Variable with period of 360° of crank angle |
| Magnitude of resultant bearing load | Constant | Variable with period of 80° of crank angle |
| Direction of resultant bearing load with respect to crank axis | Always along crank axis | Variable with period of 80° of crank angle |

TEST PROCEDURE AND CONDITIONS

Before the crankshaft is rotated, heated oil is circulated through the apparatus until the temperature of the case reaches a value of approximately 170° F. The initial run-in of the bearing is at 1800 rpm (unit load, 2260 lb/sq in.) for 45 minutes. The speed is then increased in successive increments of 200 rpm every 20 minutes until a speed of 3400 rpm (unit load, 8090 lb/sq in.) is reached, after which the speed is increased in increments of 100 rpm every 20 minutes until seizure occurs. Each speed increase is achieved over a period of approximately 2 minutes after which time the speed remains constant during the rest of the 20-minute interval. Readings of crankshaft speed, oil temperature, oil pressure, and rate of oil flow to the test bearing, temperature of oil in the sump, and torque-arm scale are periodically recorded. A chart of the power consumed by the driving motor is obtained by a recording wattmeter.

The following conditions were maintained constant throughout all the tests described herein:

| | |
|--|-----|
| Oil-inlet temperature, °F | 170 |
| Oil-inlet pressure to crankshaft, lb/sq in. | 75 |
| Value at which friction clutch will slip, lb-in. | 800 |

The oil used in all tests was Navy 1120, which has a viscosity of 100 seconds Saybolt Universal at 220° F and 1850 seconds Saybolt Universal at 100° F.

The effective oil-inlet pressure to the test bearing may be computed by adding the centrifugal-pressure component to the pressure of the oil entering the crankshaft. The centrifugal-pressure component may be computed by an application of the Bernoulli equation to give:

$$p_c = 0.427 \times 10^{-6} r^2 N^2 \quad (1)$$

where

- p_c centrifugal oil-pressure component, pounds per square inch
- r distance from center of rotation to point of oil inlet on crankpin surface, inches
- N crankshaft speed, rpm

The mean value of r for the crankpin is 4.55 inches and the average specific gravity of the oil is taken to be 0.832 at the operating temperature. The effective oil-inlet pressure is shown plotted against crankshaft speed in figure 5 for an oil-inlet pressure to the crankshaft of 75 pounds per square inch.

A drawing of the interchangeable crankpin is given in figure 6(a), which shows the specifications and oil-inlet arrangement. This oil-inlet arrangement and hardness represent an experimental design and are not used in the production engine. Individual values of crankpin diameter are given in table II.

The following four aluminum alloys were tested:

| Alloy | Nominal composition by specification, percent | | | | | | | Test |
|-------|---|-------|-------|-------|-------|-------|-------|--------|
| | Cd | Cu | Fe | Ni | Si | Sn | Al | |
| A | ----- | ----- | 0.30 | ----- | 0.40 | ----- | 99.30 | 1,7 |
| B | ----- | ----- | ----- | ----- | ----- | 6.00 | 94.00 | 2,6,9 |
| C | ----- | 1.16 | .20 | 0.87 | .19 | 6.36 | 91.22 | 3,5 |
| D | 1.50 | ----- | ----- | ----- | 4.00 | ----- | 94.50 | 4,8,10 |

Actual chemical analysis, percent
(1)

| | | | | | | | | |
|---|-------|-------|------|-------|-------|-------|-------|--------|
| A | ----- | ----- | 0.74 | ----- | 0.07 | ----- | 99.19 | 1,7 |
| B | ----- | ----- | 1.87 | ----- | ----- | 4.51 | 93.62 | 2,6,9 |
| C | ----- | 0.93 | 1.29 | 1.14 | .19 | 6.07 | 90.38 | 3,5 |
| D | 1.49 | ----- | 1.14 | ----- | 3.34 | ----- | 94.03 | 4,8,10 |

¹Determined by the Al-Fin Corp., Jamaica, N. Y.

The actual composition of each alloy is considerably different from that called for in the specifications.

A drawing of the test bearing is presented in figure 6(b). Individual bearing diameters, which are given in table III, were determined at the Cleveland Ordnance District Gage Laboratory by means of a Pratt & Whitney Electrolimit Universal Internal Comparator. The normal measuring pressure of this gage was reduced to a bare minimum so that scoring of the bearing surface by the diamond measuring point was just visible and reproducible readings could still be obtained.

RESULTS AND DISCUSSION

The load capacity of each of the 10 aluminum-alloy bearings tested is given in figure 7 together with the capacities of similar silver-lead-indium, copper-lead, silver, and silver-gold bearings, which have been included for comparison. Previous tests on copper-lead bearings show that the reproducibility of the centrifugal bearing test machine is much better than is indicated by the aluminum-alloy data of figure 7; for example, the load capacities of two copper-lead bearings having their inner and outer surfaces accurately machined using the same fixture were 8600 and 8800 pounds per square inch. The copper-lead bearing having 0.008-inch diametral clearance was tested to determine the effect of diametral clearance upon bearing-load capacity. It is evident from figure 7 that the diametral clearance within the range 0.0035 to 0.008 inch has a negligible effect upon the load capacity of the copper-lead bearings. The silver-lead-indium bearings were taken from stock and tested without any attempt to match them for dimensions; and the plain silver bearings were regular production bearings without a lead-indium coating. The silver-gold bearings were stock silver bearings with 0.0004-inch radial thickness of 24 carat gold electroplated over the silver inside surface. The large variation of load capacity in individual tests on the same aluminum alloy may be a characteristic of that aluminum alloy or may reflect the poor bearing dimensions. All the bearings tested withstood a unit bearing load greater than 6000 pounds per square inch. The two tests on alloy C indicated a load capacity in excess of 9000 pounds per square inch.

Seizure suddenly occurred and was more severe for all of the aluminum-alloy bearings tested, except test 3 using alloy C, than for silver-lead-indium, copper-lead, plain silver, or silver-gold bearings. In most cases the strength of the weld that occurred between the bearing surfaces upon seizure was of the same order of magnitude as the bond strength between bearing shell and bearing metal. A representative aluminum-alloy-bearing failure is shown in figure 8. In order to remove the bearing from the journal, it was necessary to cut through the steel shell and peel away the bearing, leaving large portions of bearing metal adhering to the crankpin.

The range of crankpin-bearing oil flow at different values of crankshaft speed is shown in figure 9 for all the aluminum-alloy bearings investigated. The curves for individual bearings lie within the shaded area and no correlation was found between bearing clearance and oil flow, probably because of the geometric inaccuracies indicated in table III. The flow through the crankpin bearing is

seen to increase appreciably with engine speed. In order to correlate oil-flow data with bearing clearances, the measurement of temperatures in the oil film was undertaken. Measurement of temperature in the low-pressure region of the oil-film at locations one-half and one-fourth the length of the bearing was accomplished by placing copper-constantan thermocouples on the unloaded side of the crankpin. The sensitive tips of the thermocouples were 0.010 inch below the true crankpin periphery and the wires were led out through the crankshaft oil hole to slip rings at the rear. The results of these tests on plain silver bearings showed that the oil-film temperatures at these points were for all purposes equal and about 10° F higher than the oil-inlet temperature (which was measured just before the oil entered the crankshaft) for the range of inlet temperature from 170° to 240° F. It is believed that this oil-temperature difference of 10° F is due to a temperature gradient along the path of the oil through the crankshaft before it reaches the test bearing surfaces and that in this type of bearing the end leakage is so great as to prevent a large part of the oil from making a complete circuit of the crankpin periphery before it is forced out the ends by the high oil-film pressures in the loaded region. The oil-film temperature in the loaded region was not measured but was undoubtedly much higher than that measured in the unloaded region.

The silver-lead-indium and copper-lead bearings, which are commercial bearing metals, were tested in order that a comparison of these materials might be made with the aluminum alloys. Representative wattmeter records for silver-lead-indium, copper-lead, and type-C aluminum-alloy bearings are shown in figure 10. In many cases an increase in load is apparently accompanied by a small amount of run-in, which is shown by the decrease of wattmeter reading with time. The average load capacity of the type-C aluminum-alloy bearings is seen to lie between those for silver-lead-indium and copper-lead bearings. The average load capacity for each of the other aluminum alloys was found to be below that for copper lead. The bearing-load capacity and operating characteristics are dependent upon the running clearance and, because the average clearances for the silver-lead-indium, copper-lead, and aluminum-alloy bearings were not identical, a comparison of load capacity of the different bearing materials should be made with this fact in mind.

Silver-lead-indium, copper-lead, and the aluminum-bearing alloys were found to differ in their ability to recover from initial seizure near the point of failure. Silver-lead-indium bearings, and to a greater extent copper-lead bearings, are capable of recovering from initial seizure if the load is decreased immediately upon seizure and

the bearing allowed to run-in a short time before the load is reapplied. This effect is illustrated at points A and B in figure 10. None of the aluminum-alloy bearings exhibited such ability to recover; this observation reflects the relative suddenness and severity with which these materials fail.

The type-C aluminum-alloy bearing apparently requires more run-in than copper-lead or silver-lead-indium bearings as indicated by the slightly higher friction at all values of load and the greater irregularity of the wattmeter record throughout the tests. The power characteristics for the other three aluminum alloys were less than those for the type-C alloy and more nearly approached the silver-lead-indium and copper-lead bearing power characteristics.

SUMMARY OF RESULTS

The results of tests made in a centrifugal bearing test machine to determine the load capacities of four aluminum-alloy crankpin bearings similar to those of a production radial-type engine may be summarized as follows:

1. The average load capacities for the aluminum alloys tested are:

| Alloy | Composition, percent | | | | | | | Unit load capacity (lb/sq in.) | Average unit load capacity (lb/sq in.) |
|-------|----------------------|------|------|------|------|------|-------|--------------------------------|--|
| | Cd | Cu | Fe | Ni | Si | Sn | Al | | |
| A | ---- | ---- | 0.74 | ---- | 0.07 | ---- | 99.19 | 8650, 7150 | 7900 |
| B | ---- | ---- | 1.87 | ---- | ---- | 4.51 | 93.62 | 6300, 8100, 7850 | 7400 |
| C | ---- | 0.93 | 1.29 | 1.14 | .19 | 6.07 | 90.38 | 9550, 9050 | 9300 |
| D | 1.49 | ---- | 1.14 | ---- | 3.34 | ---- | 94.03 | 8900, 6700, 6300 | 7300 |

2. All the aluminum-alloy bearings were found to seize more suddenly and severely than comparable copper-lead or silver-lead-indium bearings.

3. Chemical analysis made after the bearings had been tested to failure showed that the actual composition of each aluminum alloy was different from the chemical specifications. In particular, the iron content was found to be in excess of that required by the nominal specifications. Inasmuch as the iron content is reported to influence the antiscure properties of aluminum alloys, due consideration should be made of the actual composition rather than the nominal specifications in evaluating the aluminum alloys tested.

4. The physical characteristics of the bond between the aluminum alloy and steel back must be improved before the aluminum alloys can be used for radial-aircraft-engine master-rod bearings.

Aircraft Engine Research Laboratory,
National Advisory Committee for Aeronautics,
Cleveland, Ohio, May 17, 1946.

REFERENCES

1. Anon.: Railway Matters (par. 5). The Engineer, vol. 112, Nov. 10, 1911, p. 489.
2. Anon.: Aluminum Alloy Bearings. Canadian Metals and Metallurgical Ind., vol. 6, no. 1, Jan. 1943, pp. 16-17.
3. Devereaux, W. C.: Aluminum Alloys for Bearings. Metal Progress, vol. 37, no. 5, May 1940, p. 552. (Abs. from "The Use of Light Alloys in Modern Design," Inst. Auto. Eng. Jour. (London), vol. 6, Feb. 1938, pp. 47-63.)
4. Ryder, Earle A.: A Machine for Testing Bearings. Metals and Alloys, vol. 11, no. 3, March 1940, pp. 69-74.
5. Koffel, William K., and Biermann, Arnold E.: A Unit Laboratory Engine Oil System Providing for a Remote Indication of Oil Flow and Oil Consumption Together with Blow-by Measurement. NACA TN No. 952, 1944.
6. Shaw, Milton C., and Macks, E. Fred: Radial Aircraft-Engine Bearing Loads. I - Crankpin-Bearings Loads for Engines Having Nine Cylinders Per Crankpin. NACA ARR No. E5H10a, 1945.

TABLE I - COMPOSITION AND OPERATING PROPERTIES OF SOME ALUMINUM-ALLOY BEARINGS

| Alloy | Composition, percent | | | | | | | | | | | Remarks | Reference |
|------------------------------------|----------------------|------|-----------|------------|------------|------------|------------|--------------|------------|------|-------|---|-----------|
| | Sb | Co | Cu | Fe | Mg | Mn | Ni | Si | Sn | Zn | Al | | |
| Cu - Al | ---- | ---- | 8.0 | ---- | ---- | ---- | ---- | ---- | ---- | ---- | 92.0 | Some bearings of this composition have given 50,000 miles of railroad service without measurable wear | 1 |
| Quarzal | ---- | ---- | 5.0 | 1.0 | ---- | ---- | ---- | ---- | ---- | ---- | 94.0 | Has been run to 1650 lb/sq in. at a rubbing speed of 20 ft/sec | 2 |
| Neomagnal A | ---- | ---- | ---- | ---- | 5.0 | ---- | ---- | ---- | ---- | 5.0 | 90.0 | Load capacity of 8500 lb/sq in. at 10 ft/sec | 2 |
| KS 290 | ---- | 1.2 | 1.5 | ---- | 0.5 | 0.6 | 1.5 | 21.0 22.0 | ---- | ---- | Bal. | No wear after operating for 100 hours at 5500 lb/sq in. and 17 ft/sec | 2 |
| Cast (eutectic) | ---- | ---- | 4.5 | ---- | 0.7 | 0.8 | 1.5 | 14.0 | ---- | ---- | 79.5 | Rotating bearing on stationary, hardened shaft carried up to 12,750 lb/sq in. | 2 |
| RR.56 | ---- | ---- | 0.6 .9 | 0.2 .45 | ---- | 0.7 1.0 | 1.4 1.7 | ---- | 5.5 7.0 | ---- | Bal. | Standard crankpin bearings on Rolls-Royce and Bentley engines | 2 |
| RR. Main bearings | 0.4 .8 | ---- | ---- | ---- | 0.35 .5 | 0.7 .9 | 1.6 2.0 | 0.45 .60 | 4.6 5.0 | ---- | Bal. | Standard main bearings on Rolls-Royce and Bentley engines | 2 |
| Alloy used in tests of reference 3 | ---- | ---- | 2.0 | 1.2 | 0.8 | ---- | 1.3 | 0.6 | 0.07 | ---- | 94.03 | Replaced lead bronze in service and withstood severe treatment | 3 |

NACA TN No. 1108

TABLE II - CRANKPIN MEASUREMENTS

[Determined at Cleveland Ordnance District Gage Laboratory by means of Pratt & Whitney Length Measuring machine]

| Plane of diametral readings ^a | Diameter of crankpin (in.) | | | | |
|--|----------------------------|---------|------------|---------|---------|
| | Section ^b | | | | |
| | 1-1 | 2-2 | 3-3 | 4-4 | 5-5 |
| | Before testing | | | | |
| A-A | 3.25135 | 3.25115 | Oil groove | 3.25100 | 3.25110 |
| B-B | 3.25150 | 3.25140 | Oil groove | 3.25110 | 3.25137 |
| C-C | 3.25149 | 3.25120 | 3.25109 | 3.25100 | 3.25150 |
| D-D | 3.25117 | 3.25104 | 3.25090 | 3.25090 | 3.25120 |
| | After testing | | | | |
| A-A | 3.25106 | 3.25070 | Oil groove | 3.25080 | 3.25100 |
| B-B | 3.25100 | 3.25085 | Oil groove | 3.25080 | 3.25103 |
| C-C | 3.25110 | 3.25050 | 3.25090 | 3.25073 | 3.25114 |
| D-D | 3.25080 | 3.25090 | 3.25073 | 3.25086 | 3.25111 |

| | Before testing (in.) | After testing (in.) |
|--|----------------------|---------------------|
| Maximum taper in any plane | 0.00049 | 0.00060 |
| Maximum out-of-round at any section | .00036 | .00040 |
| Average outside diameter | 3.25119 | 3.25089 |
| Total average change in crankpin diameter due to wear and polishing (for the series of 10 tests) | | .00030 |

^aPlanes of diametral readings are shown in the following sketch:

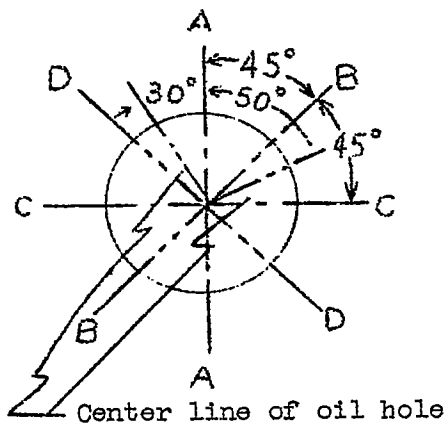

^bSections at which measurements of the diameter were taken are as shown:

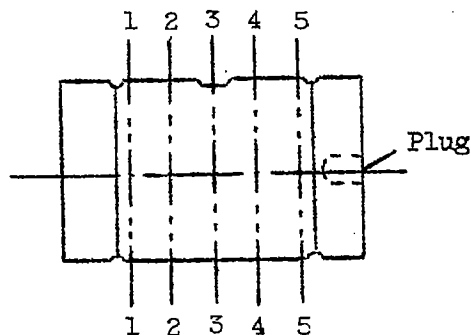
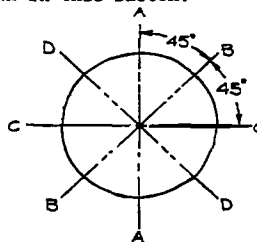

TABLE III - INDIVIDUAL TEST BEARING MEASUREMENTS

[Determined at the Cleveland Ordnance District Gage Laboratory by means of a Pratt & Whitney
Electrolimit Universal Internal Comparator]

| Bearing | Plane of diametral reading ^a | Inside diametral reading ^b (in.) | | | Maximum taper in any plane (in.) | Maximum out-of-round at any section (in.) | Average inside diameter (in.) | Estimated average clearance with crankpin ^c (in.) | Average outside diameter (in.) |
|---------|---|---|---------|---------|----------------------------------|---|-------------------------------|--|--------------------------------|
| | | Section | | | | | | | |
| | | 1-1 | 2-2 | 3-3 | | | | | |
| 1 | A-A | 3.25366 | 3.25405 | 3.25450 | 0.00170 | 0.00144 | 3.25434 | 0.00315 | 3.47096 |
| | B-B | 3.25430 | 3.25470 | 3.25470 | | | | | |
| | C-C | 3.25510 | 3.25450 | 3.25340 | | | | | |
| | D-D | 3.25418 | 3.25403 | 3.25460 | | | | | |
| 2 | A-A | 3.25550 | 3.25540 | 3.25500 | 0.00110 | 0.00160 | 3.25443 | 0.00327 | 3.47079 |
| | B-B | 3.25510 | 3.25425 | 3.25400 | | | | | |
| | C-C | 3.25390 | 3.25360 | 3.25342 | | | | | |
| | D-D | 3.25400 | 3.25400 | 3.25500 | | | | | |
| 3 | A-A | 3.25480 | 3.25390 | 3.25320 | 0.00160 | 0.00188 | 3.25445 | 0.00332 | 3.47091 |
| | B-B | 3.25445 | 3.25437 | 3.25438 | | | | | |
| | C-C | 3.25440 | 3.25480 | 3.25508 | | | | | |
| | D-D | 3.25460 | 3.25465 | 3.25480 | | | | | |
| 4 | A-A | 3.25470 | 3.25456 | 3.25495 | 0.00050 | 0.00115 | 3.25428 | 0.00318 | 3.47088 |
| | B-B | 3.25440 | 3.25390 | 3.25408 | | | | | |
| | C-C | 3.25390 | 3.25360 | 3.25380 | | | | | |
| | D-D | 3.25440 | 3.25430 | 3.25480 | | | | | |
| 5 | A-A | 3.25415 | 3.25365 | 3.25460 | 0.00180 | 0.00190 | 3.25438 | 0.00331 | 3.47086 |
| | B-B | 3.25340 | 3.25390 | 3.25320 | | | | | |
| | C-C | 3.25455 | 3.25425 | 3.25320 | | | | | |
| | D-D | 3.25530 | 3.25440 | 3.25400 | | | | | |
| 6 | A-A | 3.25540 | 3.25510 | 3.25386 | 0.00154 | 0.00160 | 3.25444 | 0.00340 | 3.47074 |
| | B-B | 3.25430 | 3.25440 | 3.25498 | | | | | |
| | C-C | 3.25380 | 3.25380 | 3.25392 | | | | | |
| | D-D | 3.25510 | 3.25448 | 3.25422 | | | | | |
| 7 | A-A | 3.25505 | 3.25460 | 3.25480 | 0.00090 | 0.00180 | 3.25466 | 0.00365 | 3.47079 |
| | B-B | 3.25360 | 3.25372 | 3.25450 | | | | | |
| | C-C | 3.25450 | 3.25455 | 3.25510 | | | | | |
| | D-D | 3.25560 | 3.25490 | 3.25505 | | | | | |
| 8 | A-A | 3.25460 | 3.25460 | 3.25520 | 0.00068 | 0.00100 | 3.25462 | 0.00364 | 3.47082 |
| | B-B | 3.25520 | 3.25490 | 3.25490 | | | | | |
| | C-C | 3.25478 | 3.25410 | 3.25430 | | | | | |
| | D-D | 3.25420 | 3.25420 | 3.25450 | | | | | |
| 9 | A-A | 3.25490 | 3.25425 | 3.25390 | 0.00140 | 0.00190 | 3.25455 | 0.00360 | 3.47051 |
| | B-B | 3.25590 | 3.25460 | 3.25530 | | | | | |
| | C-C | 3.25460 | 3.25430 | 3.25460 | | | | | |
| | D-D | 3.25460 | 3.25430 | 3.25340 | | | | | |
| 10 | A-A | 3.25520 | 3.25520 | 3.25680 | 0.00170 | 0.00395 | 3.25443 | 0.00351 | 3.47102 |
| | B-B | 3.25410 | 3.25350 | 3.25340 | | | | | |
| | C-C | 3.25380 | 3.25310 | 3.25285 | | | | | |
| | D-D | 3.25570 | 3.25550 | 3.25400 | | | | | |

^aPlanes of diametral readings are as shown in this sketch:



^bDiametral readings are made at sections as shown:

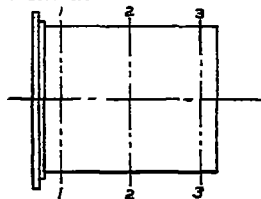

^cEstimated average clearance equals [average inside diameter of bearing minus average outside diameter of crankpin before series of tests minus 0.00003 (test number minus 1)].

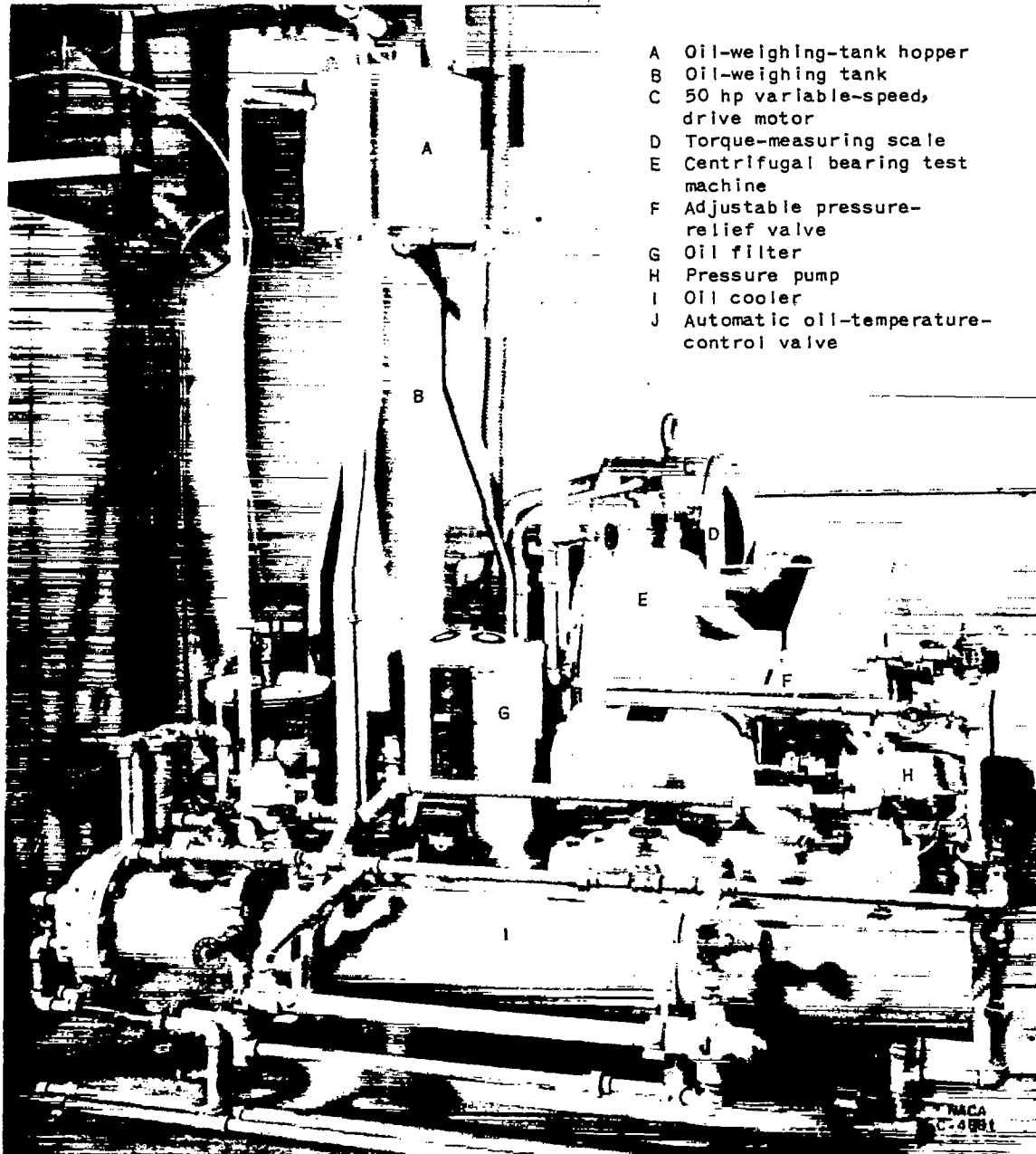

- A Oil-weighing-tank hopper
- B Oil-weighing tank
- C 50 hp variable-speed,
drive motor
- D Torque-measuring scale
- E Centrifugal bearing test
machine
- F Adjustable pressure-
relief valve
- G Oil filter
- H Pressure pump
- I Oil cooler
- J Automatic oil-temperature-
control valve

Figure 1. - Centrifugal bearing test machine and accessory equipment.

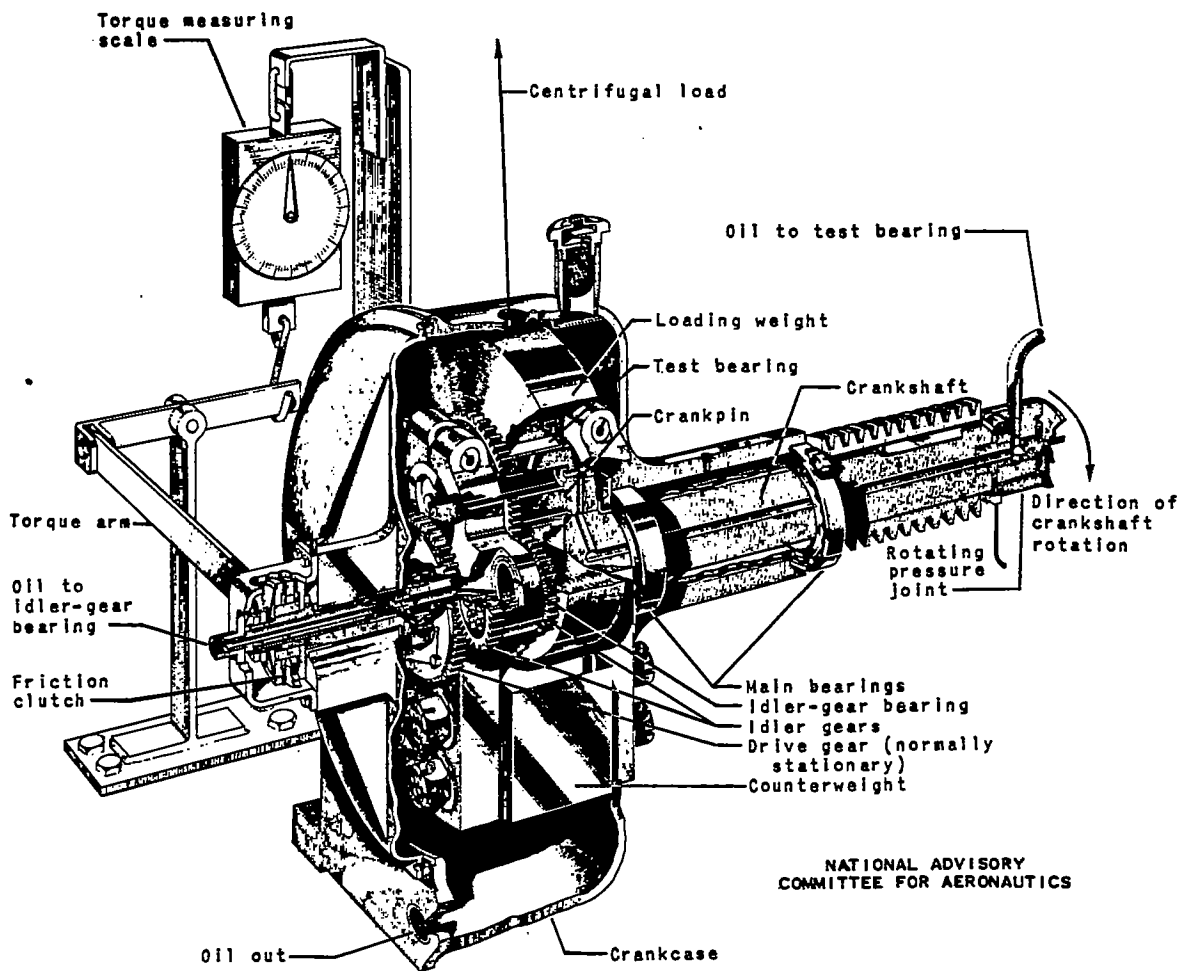
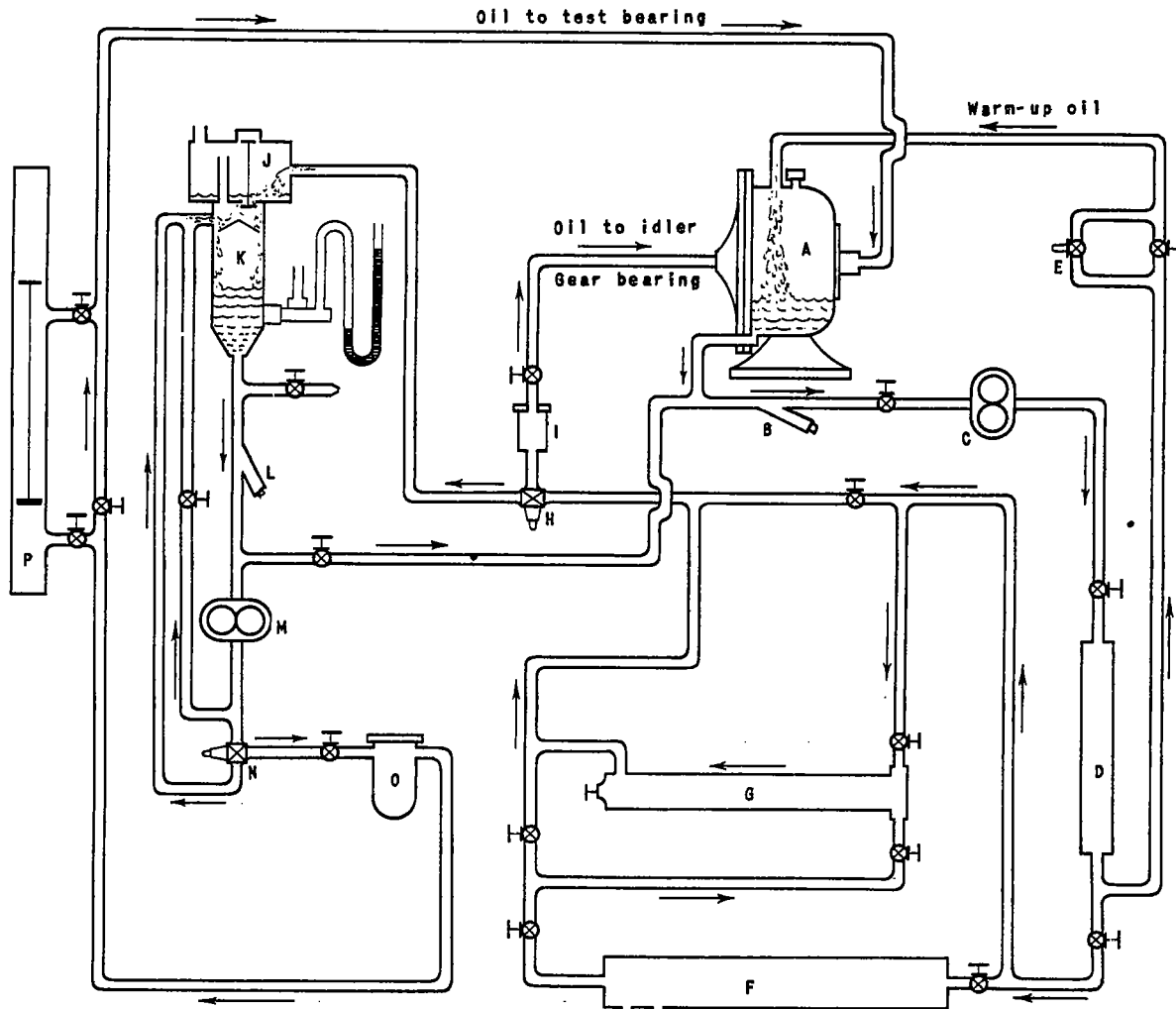

Figure 2. - Centrifugal bearing test machine.

55 + 392



- A Centrifugal bearing test machine
- B Oil strainer
- C Scavenge pump
- D Oil heater
- E Safety valve
- F Oil cooler
- G Automatic oil-temperature-control valve
- H Adjustable pressure-relief valve
- I Oil filter
- J Oil-weighing-tank hopper
- K Oil-weighing tank
- L Oil strainer
- M Pressure pump
- N Adjustable pressure-relief valve
- O Oil filter
- P Oil rotameter

NATIONAL ADVISORY
COMMITTEE FOR AERONAUTICS

Figure 3. - Oil system of centrifugal bearing test machine.

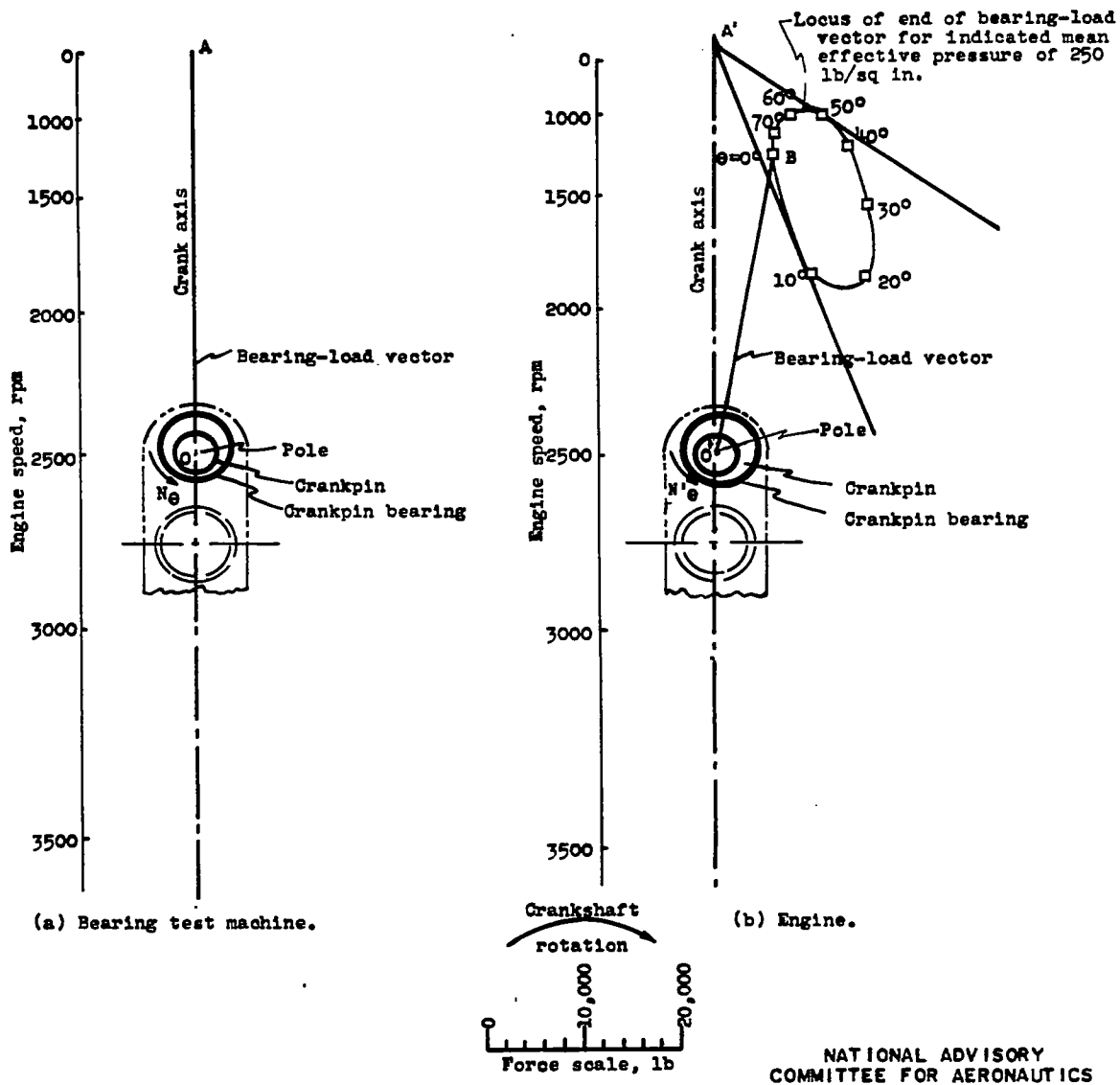

Figure 4. - Comparison of load and speed characteristics of crankpin bearing (similar to that used in production, nine-cylinder, radial-type engine) in centrifugal bearing test machine with that for comparable bearing in actual engine.

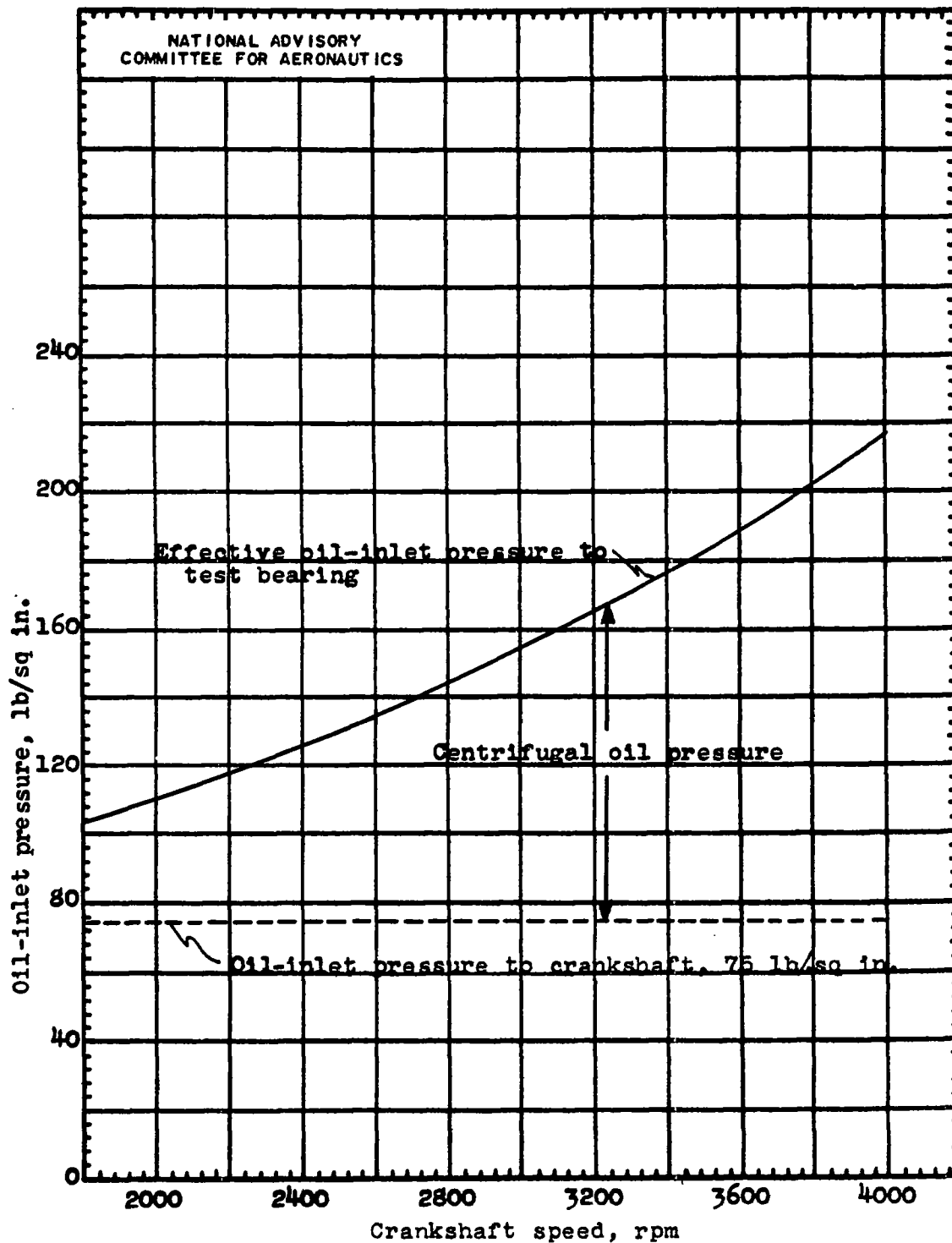

Figure 5.- Variation of effective oil-inlet pressure to test bearing with crankshaft speed for centrifugal bearing test machine.

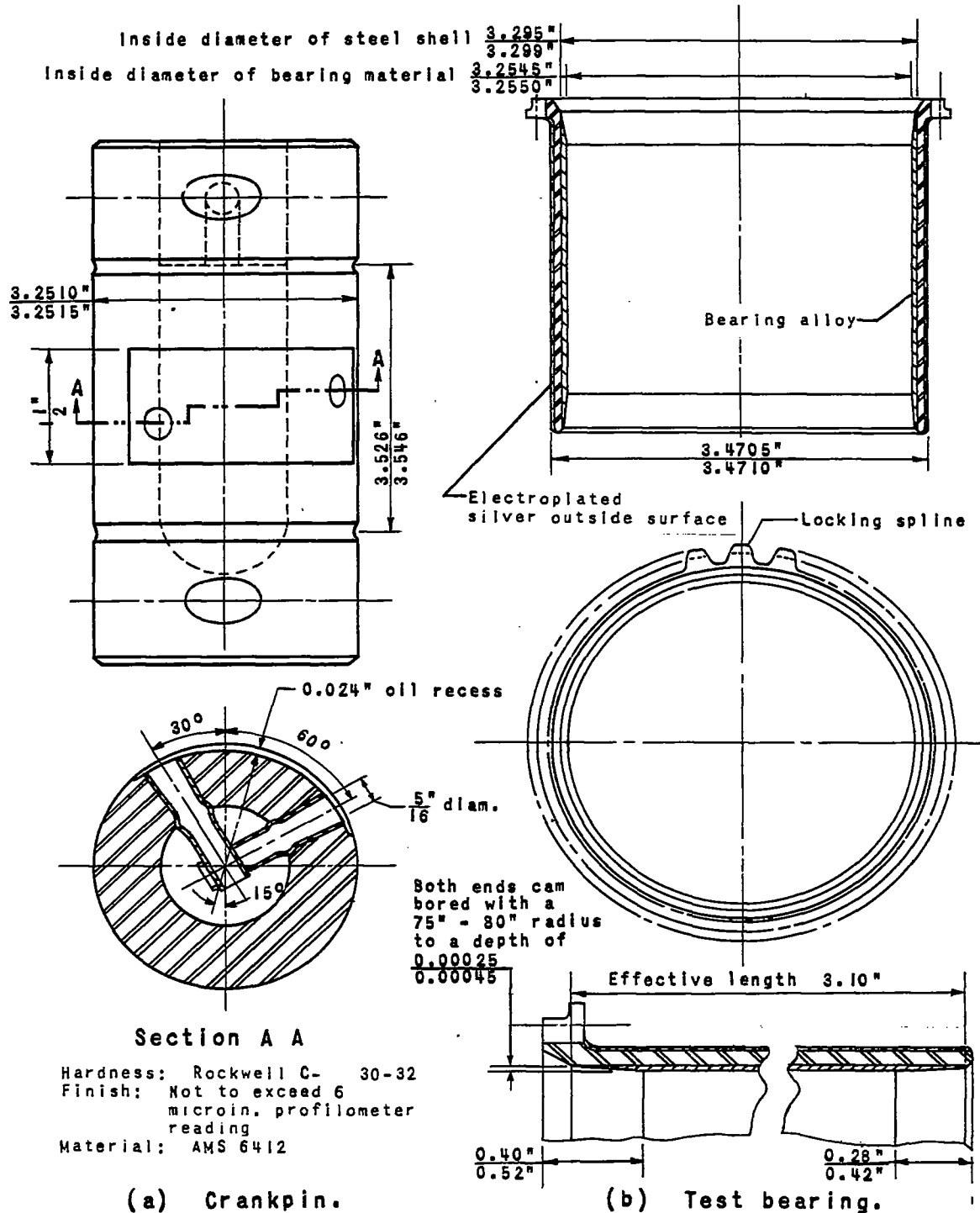

Figure 6. - Crankpin and test bearing used in centrifugal bearing test machine.

55+416

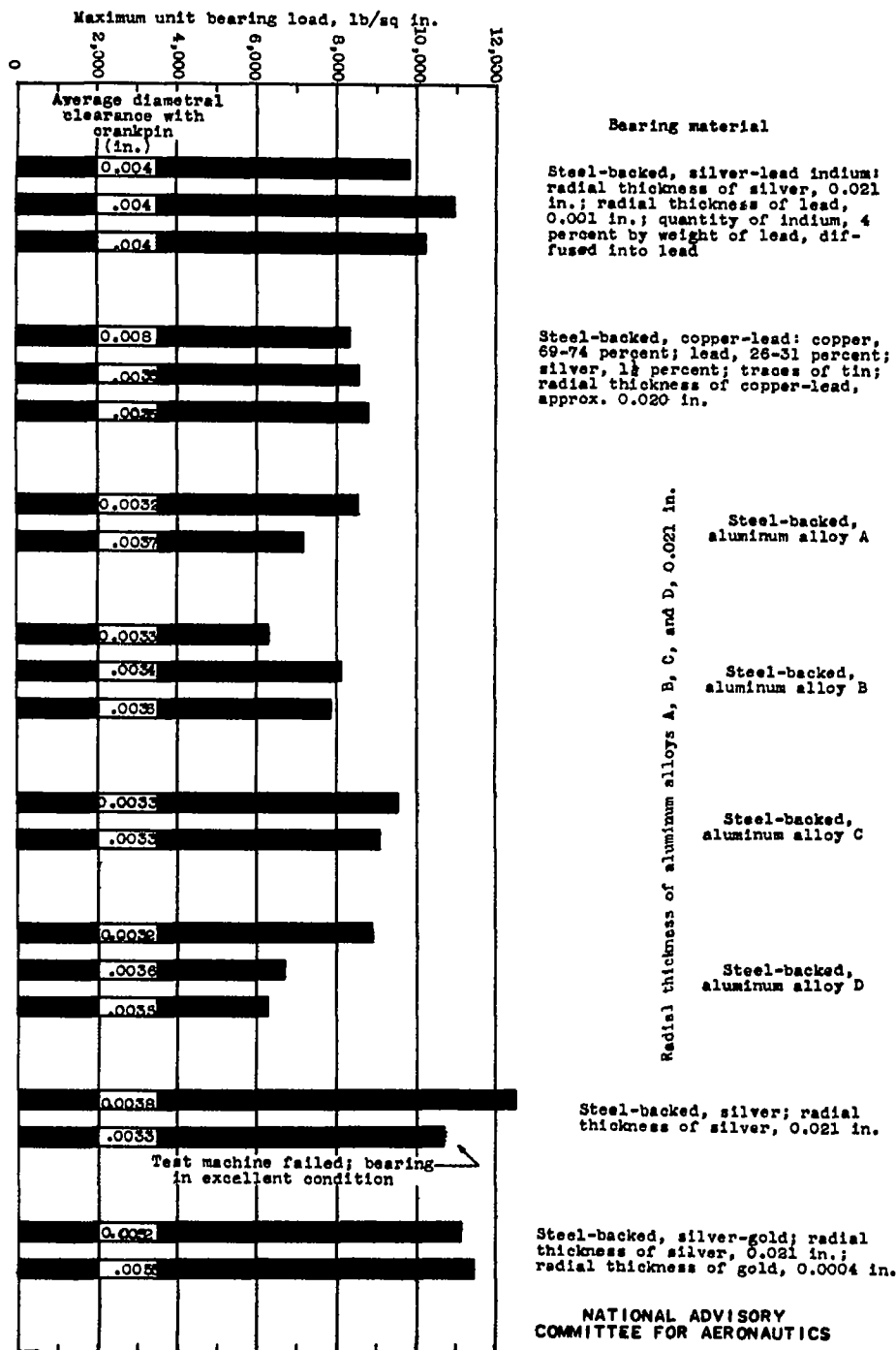

Figure 7. - Bar graph showing unit load capacity of four different aluminum-alloy, master-rod bearings similar to those of production radial-type engine as compared with similar silver-lead-indium, copper-lead, silver, and silver-gold bearings as tested in centrifugal bearing test machine. Effective bearing area, 10.1 square inches.

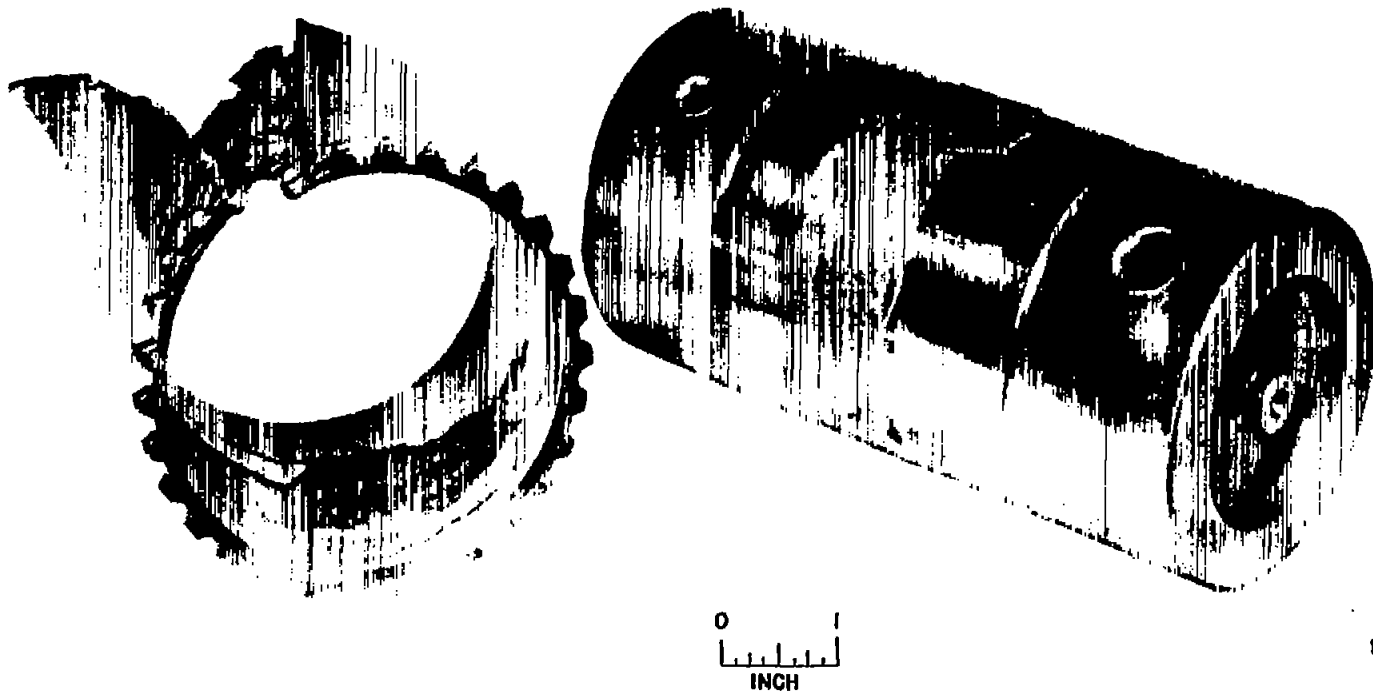

Figure 8. - Representative aluminum-alloy bearing failure. (Test 4; maximum load 90,000 lb at 3560 rpm.)

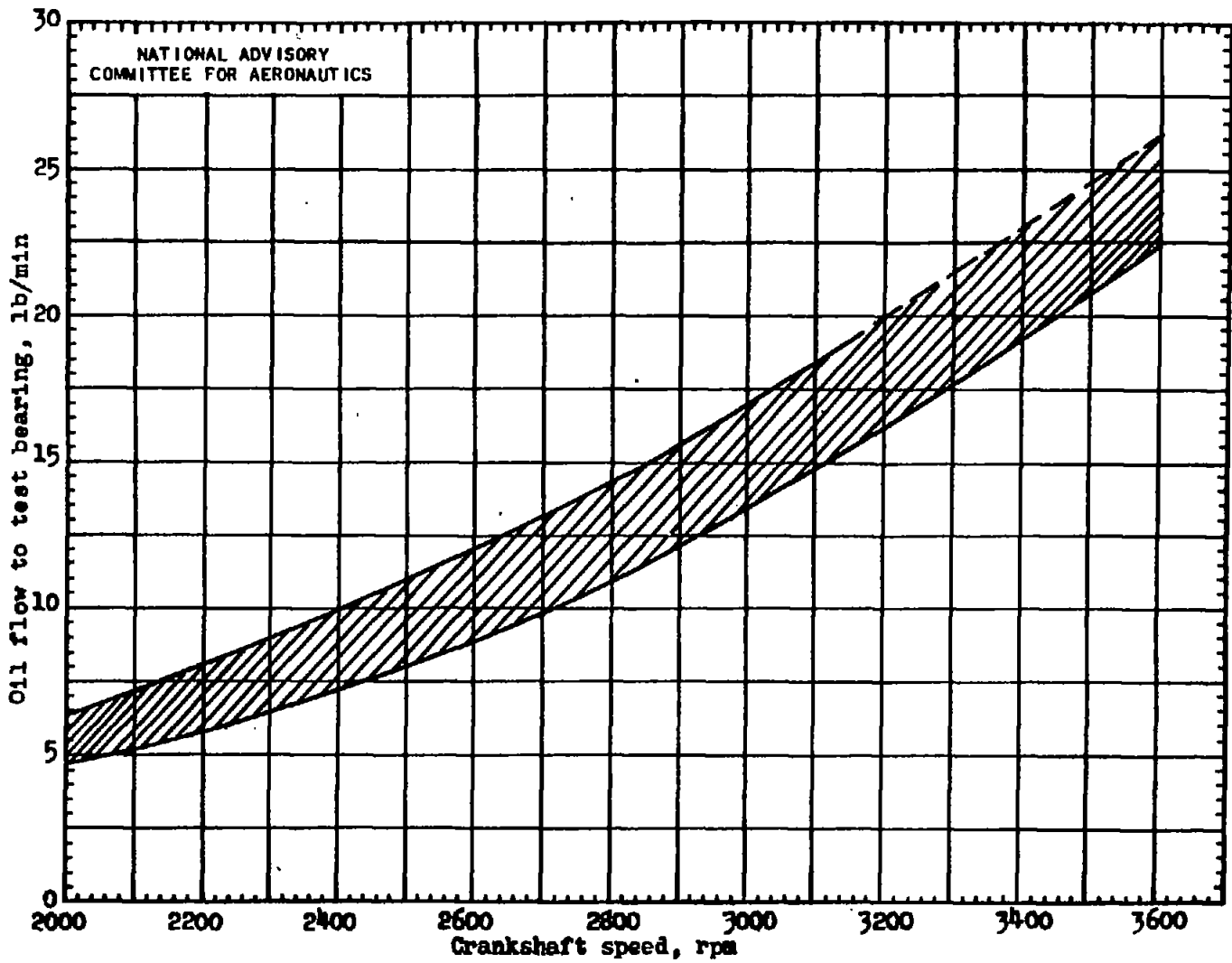

Figure 9.- Range of oil flow at different crankshaft speeds for 10 aluminum-alloy crankpin bearings similar to those of production radial-type engine as tested in centrifugal bearing test machine.

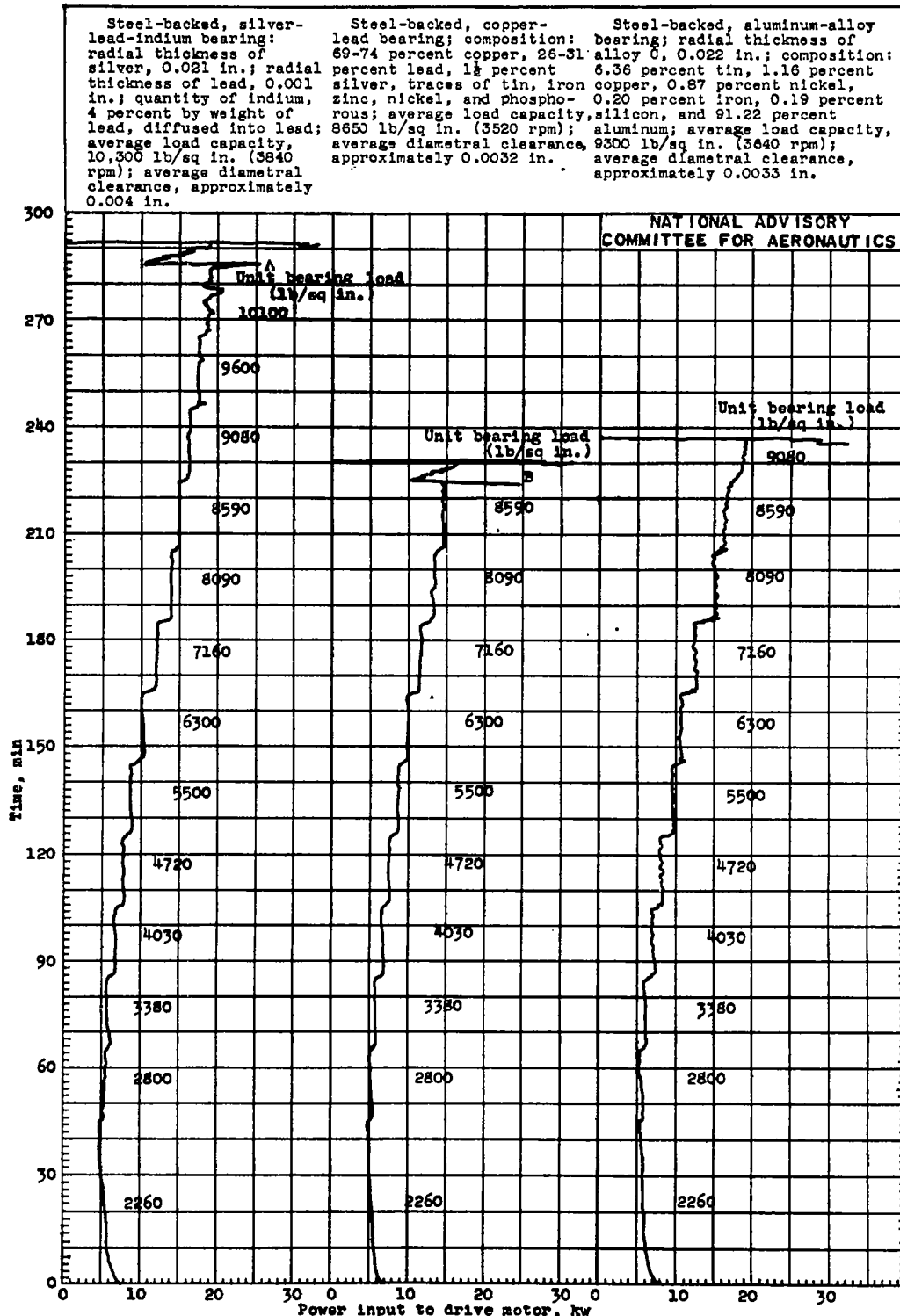

Figure 10. - Representative wattmeter records showing comparison of silver-lead-indium, copper-lead, and type-C aluminum-alloy bearings, as tested in the centrifugal bearing test machine. The projected bearing area is taken as 10.1 square inches.